

Isokern® STANDARD® Fireplace

with Fire-Lite Application

and DM Chimney System

Installation, Operation, Maintenance and Owner's Manual

STANDARD Models 80S36, 80S42 & 80S46

A PRODUCT OF EARTHCORE INDUSTRIES, LLC.

IMPORTANT: This manual contains assembly rules, installation steps, guidelines, use and maintenance instructions for the STANDARD 80S36, 80S42 & 80S46 fireplaces and the DM chimney system, and Fire-Lite Application with the ECO-STEEL & ECOSTEEL+ Chimney System. This manual must become the property of and be reviewed by all current and future users of this product. It is the responsibility of the general contractor and the installer of this product to ensure that the instructions in this manual are followed exactly and that any allowed gas log appliance used in this product be installed in strict accordance with NFPA 58, NFPA 54/ANSI Z223.1 and the gas log manufacturer's explicit installation, sizing, and operation instructions. It is the responsibility of the general contractor to provide adequate clearances from all firebox surfaces as specified in this manual.

INSTALLER: Leave this manual with the fireplace
CONSUMER: Retain this manual for future reference

**Be Sure to Read Entire Manual Before Beginning Construction.
Contents of this manual may change without prior notification.**

DO NOT install the STANDARD Series Fireplace in a manufactured home or mobile home or recreational vehicle.

SBCCI NO. 9626
NYC-MEA 241-90-E
ICC Report NO. ESR-2316
LA RR NO. 25483
IBC 2006, IRC 2006, IMC 2006
Listing Services Report NO. 3159656MID-008 & 3082504-T1



Issued: July 2023
Revision: 004
©2023 Earthcore Industries, LLC

**THESE FIREPLACES ARE DESIGNED for USE with:
Solid Wood Logs, PROPANE (LP) or NATURAL GAS (NG), ONLY**

THIS MANUAL CAN ONLY BE REPRODUCED IN ITS ENTIRETY

Table of Contents

General Information	3-4
Safety Instructions	5-6
UL 127 Listing Label	7
STANDARD 36 - Firebox Dimensions	8
Component List - STANDARD 36	9
STANDARD 42 - Firebox Dimensions	10
Component List - STANDARD 42	11
STANDARD 46 - Firebox Dimensions	12
Component List - STANDARD 46	13
Required Clearance to Combustibles	14-15
Supporting Floor System	16
Fire-Lite Application	17-19
Rough Framing Dimensions	20
General Assembly Instructions	21-25
DM Chimney & General Information	26
DM Chimney Height Requirements	27
DM Chimney Installation - Straight Run	28-29
DM Chimney Installation—Offset Run	30-32
DM Brick Ledge	33-35
DM Chimney Crown Caps	35
DM Chimney Terminations	36
ECO-Steel/ECO-Steel+ Metal Chimney	37
Component List ECO-Steel	38
Component List ECO-Steel+	39-40
Eco-Steel & Eco-Steel+ General Information	41
Eco-Steel Metal Chimney Installation	42-46
Mechanical Draft System	47
Access Modification: Combustion Air Kits, Gas & Electrical Line Feed	48
Firebrick Installation	49
Flush Wall Finish Details	50
Clearance to Combustible Trim	51
Outdoor Application	52
Two-Story Stacked Installations	53-54
See-Thru Specialty Application/Seismic Requirements	55
Summary	56-58
Registration Card	59
Warranty	60

General Information

The STANDARD Series fireplace and DM chimney system is a prefabricated, refractory modular fireplace and chimney system designed for field assembly. The system consists of interlocking precast parts which are adhered versus glued together with a masonry adhesive. The parts of the STANDARD Series fireplace and DM chimney system are precast using a proprietary mixture of volcanic pumice aggregate and cement. It includes all the parts necessary for assembly of a complete firebox, smoke dome and chimney system.

Each STANDARD precast fireplace component is designed for a specific part of the fireplace such that only one means for assembly is possible.

The firebox and smoke dome are designed to be fitted with a traditional cast iron, poker-style throat damper, however, metal flue pipe, electronic, or chimney top dampers are options.

The STANDARD Series fireplaces are available in three sizes: 36, 42 & 46.

The STANDARD Series fireplace requires a standard refractory firebrick liner be applied to the interior of the firebox. In the 36, 42 & 46 models the firebrick must be a minimum thickness of 1-1/8" on the side walls, floor, and back wall.

All units have a (32") rough opening height before firebrick. The only parts which differ among the available sizes are width related pieces. All units use the same side wall pieces.

The DM chimney system is a dual module refractory chimney system. The basic chimney consists of an outer casing block and an inner liner. It is acceptable to use mechanical assist draft systems, if the venting companies perform the engineering calculations and make the necessary recommendations for fan size and flue vent diameter following the guidelines of NFPA 211/2023, pg. 211-13. Installation of such systems must also follow the mechanical drafting company's explicit installation and operation instructions.

"Smoke-free" operation is not warranted nor is the manufacturer responsible for inadequate system draft caused by mechanical systems, general construction conditions, inadequate chimney heights, adverse wind conditions or any unusual environmental conditions or factors beyond the manufacturer's control.

The DM chimney components are field assembled using Earthcore Adhesive to glue the components together. The DM chimney system also includes an offset chimney block component, used to create offsets to the vertical run of the chimney. A brick ledge component is available, designed to support chimney top brick veneer finishes. Prefabricated masonry chimney termination caps are also available.

The STANDARD Series fireplace and DM chimney components will be described and illustrated in the following pages. Close attention should be paid to each component group's specifications and installation requirements as described in this manual.

Recommended minimum overall height for the Isokern fireplace, DM, ECO-STEEL & ECO-STEEL + chimney system for an indoor application is 18'-0" when the chimney is straight and 21'-0" when a chimney is offset.

Maximum DM54 Chimney height without additional support needed: 57' – 0"

Overall DM54 Chimney height, with proper structural support, should not exceed: 82 – 0"

Intended Product Use Statement: The STANDARD Series fireplace and DM chimney systems are intended to burn solid wood fuel, propane, or natural gas.

NOTE: Installation of a gas pipe must comply with the Standard for Decorative Gas Appliances for Installation in Vented Fireplaces, ANSI Z21.60.

This fireplace is intended for use as a supplemental heat source only and is not intended for heavy use as a primary heating system. Over-firing, abusive burning or mistreatment will void any claims (e.g., burning construction debris or other highly flammable material, tossing, kicking, or otherwise forcing logs into the firebox).

The STANDARD Series fireplaces and DM chimney systems are conventional indoor or outdoor fireplaces designed to appear like traditional masonry fireplaces. The STANDARD Series fireplace and DM chimney system units are intended for installation in residential homes and other buildings of conventional construction.

NOTE: The local authority having code jurisdiction should be consulted before installation to determine the need to obtain a permit.

General Information

Important areas of concern with the installation of these fireplaces are construction of proper load bearing foundation and concrete support slab; code required hearth extension substrates and supports; proper assembly of components; clearance to combustible materials; height of chimney; and techniques employed in applying finishing materials to the fireplace opening and hearth extension.

Each of these important topics will be covered in detail throughout this manual. Installation personnel must give special attention to each topic as the installation progresses.

All work performed on, near and adjoining the fireplace and chimney installation must meet or exceed the specifications and requirements in this manual and the prevailing local building code.

Subsequent renovations, additions of cabinets and storage spaces in the enclosure surrounding the fireplace are also limited to the specifications in this manual and to the prevailing local building code.

Isokern is not responsible for other construction work around the fireplace unit.

We recommend (1) 4" outside air kit for Standard 36, 42 & 46.

The STANDARD Series fireplace and DM chimney system is tested and listed by Warnock Hersey (Intertek Testing Service) - Report No. 3159656MID-008 & 3082504-T1 to UL 127, and UL 103HT.

STANDARD Series fireplace systems are also designed for installation in accordance with the National Fire Protection Association Standard for chimneys, fireplaces, vents, and Solid Fuel-Burning Appliances (NFPA 211).

SEISMIC CODE:

If you are installing the STANDARD Series Fireplace in a location where there is seismic code, follow these instructions for installation:

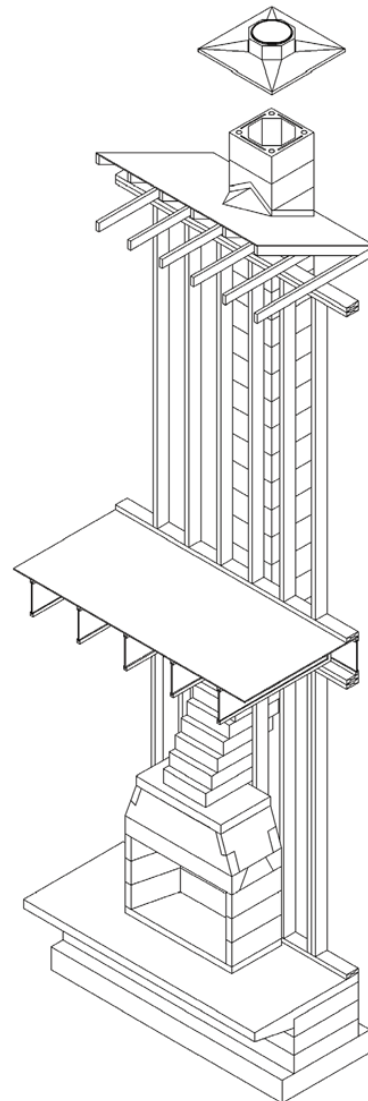
Four No. 4 ASTM A615 Grade 40 minimum, vertical reinforcing bars, 2 on the inside of each side wall cavity running from approximately 4 inches into the concrete slab (for anchorage) to the top of the sidewall cavity and fill with 2000psi minimum concrete or grout. Also see page 55 for more information.

For seismic anchorage design and instructions of the flush hearth application, please contact the Technical Department at 1-800-642-2920.

IMPORTANT: The top plate of the firebox is not meant to be used as a structural support. Please consult structural engineer for structural support of any veneer bearing weight on the Isokern top plate.

NOTE: Do not scale drawings. Illustrations in this manual are not to scale and are intended to show "typical" installations.

Nominal dimensions are given for design and framing reference only since actual installations may vary due to job specific design preferences. Always maintain the stated minimum clearances to combustible materials. Do not violate any specific installation requirements.



Safety Instructions

WARNING: This product contains or generates chemicals known to the state of California to cause cancer or birth defects or other reproductive harm.

IMPORTANT: Read this owner's manual carefully and completely before trying to assemble, operate, or service this fireplace. Improper use of this fireplace can cause serious injury or death from fire, burns, explosions and carbon monoxide poisoning.

DANGER: CARBON MONOXIDE POISONING MAY LEAD TO DEATH!

If gas application is used with STANDARD Series fireplace; Propane (LP) gas and natural gas (NG) are both colorless and odorless gases. An odor-making agent is added to each of these gases to help you detect a gas leak. However, the odor added to these gases can fade and gas may be present even though no odor exists.

Carbon Monoxide Poisoning: Early signs of carbon monoxide poisoning resemble flu symptoms, including headaches, dizziness, or nausea. If you have these signs the fireplace may not have been installed properly, get fresh air at once! Have the fireplace inspected and serviced by a qualified service person or your gas supplier. Some people are more affected by carbon monoxide than others. These include pregnant women, people with heart or lung diseases or anemia, people at high altitude or under the influence of alcohol. Earthcore Industries strongly recommends the use of a carbon monoxide detector/alarm device wherever gas fired appliances are in use.

All parties either involved in or associated with the installation, service, and use of this fireplace must read this entire manual. Keep this manual for reference and as a guidebook to safe operation of this fireplace.

1. Always check local building codes governing fireplaces and fireplace installations. The STANDARD Series fireplace and DM chimney installation must comply with all local, regional, state, and national codes and regulations.
2. The STANDARD Series fireplace and DM chimney systems are intended for use in any application where a traditional masonry type fireplace would apply. The chimney system must always vent vertically to the outside of the building.
3. Creosote and soot formation and the need for removal: When wood is burned slowly, it produces tar and other organic vapors which combine with expelled moisture to form creosote. The creosote vapors condense in the relatively cool chimney flue of a slow burning fire. As a result, creosote residue accumulates on the flue lining. When ignited this creosote makes an extremely hot fire. Due to creosote and soot buildup it is necessary to inspect and clean the fireplace and chimney prior to use and periodically during the heating season. Cleaning of the fireplace and the chimney system should be done annually at a minimum. In colder climates, chimney cleaning may need to be done periodically throughout the heating season.
4. Before servicing, allow the fireplace to cool. Always shut off any electricity or gas to the fireplace while working on it.
5. Use only solid fuel or Natural Gas or LP Gas log sets in this unit. Do not use artificial wax-based logs, chemical chimney cleaners or flame colorants in this fireplace.
6. For propane (LP) use do not place propane supply tank(s) inside any structure. Locate propane supply tank(s) outdoors. To prevent performance problems, do not use propane fuel tank of less than 100 lbs. capacity.
7. Never use gasoline, kerosene, gasoline-type lantern fuel, charcoal lighter fluid, or similar liquids to start or "freshen up" a fire in this fireplace. Keep all flammable liquids at a safe distance from the fireplace.
8. Always keep the flue damper open when heat is present in the fireplace.
9. Do not use a fireplace insert or any other product not specified for use with the STANDARD Series fireplace and DM chimney systems unless written authorization is given by Earthcore Industries, LLC. Failure to heed this warning may cause a fire hazard and will void the warranty.
10. This fireplace is not intended to heat an entire home or to be used as a primary heat source. It is designed to ensure homeowner comfort by providing supplemental heat to the room.
11. Always ensure that an adequate supply of replacement combustion air from the outside of the house is accessible to the fire to support normal combustion. Fireplaces consume large volumes of air during the normal firing process. In the event the home is tightly sealed and has modern energy efficient features, the recommended combustion air supply kits may not provide all the air required to support combustion and the proper flow of combustion gases up the chimney. The manufacturer is not responsible for any smoking or related problems that may result from the lack of adequate air supply flowing into the house. It is the responsibility of the builder/ contractor to ensure that adequate air supply has been provided for the fireplace.

CAUTION: When used with the STANDARD Series fireplace system, all gas log sets must be operated with the damper clamped in the fully open position. This includes unlisted "vent free" log sets. Only listed "vent free" log sets may be operated with the damper in the closed position.

Safety Instructions

12. When in doubt about a component's usability - has visible or suspected physical damage - consult your Isokern distributor or authorized Isokern representative for advice.
13. Modification to STANDARD components not mentioned in this manual may void claims, listings and approvals and could result in an unsafe and potentially dangerous installation.

Alterations to the STANDARD firebox are allowed with prior written approval and instructions from Earthcore Industries, LLC. The installer indemnifies the manufacturer of all claims and under no circumstances will the manufacturer be liable for consequential, incidental, indirect, punitive, or other damages of any kind or nature, whether foreseeable or not, based on any claim by any party as to the modifications of the Isokern fireplaces.


14. Keep all insulation, vapor barriers, "house wrap" paper and other insulating type membranes and products, including fiberglass, cellulose and other insulation, (anything that carries an "R" rating) a minimum of three inches (3") away from all firebox and chimney surfaces.

EXCEPTION: If insulation is used in walls surrounding the fireplace, insulation may be installed behind sheathing of gypsum board, plywood, particle board or other material on the side facing the Isokern. The facing material cannot be within 1-1/2" to the sidewalls and backwalls of the fireplace.

WARNING: Do not pack required air spaces with insulation or other materials.

15. Never leave children unattended when there is a fire burning in the fireplace.
16. Burning some fuels (such as charcoal) can be hazardous due to the possibility of producing carbon monoxide, a colorless, odorless gas. Early signs of carbon monoxide poisoning resemble flu symptoms, including headaches, dizziness, or nausea. Overexposure to carbon monoxide can lead to illness and death. It is strongly recommended to install smoke and carbon monoxide alarm / detector devices wherever fireplaces are installed.
17. Young children should be carefully supervised when they are in the same room as the appliance. Toddlers, young children, and others may be susceptible to accidental contact burns. A physical barrier is recommended if there are at-risk individuals in the house. To restrict access to the fireplace, install an adjustable safety gate to keep toddlers, young children, and other at-risk individuals out of the room and away from hot surfaces.
18. Clothing or flammable material should not be placed on or near the fireplace.
19. Due to high temperatures, the fireplace should be located out of traffic and away from furniture and draperies.
- 20. Do not nail or screw into the Isokern fireplace, which includes firebox, smoke dome and DM Chimney components unless attaching the anchor plate for the metal flue system. This may alter the integrity of the fireplace and cause a house fire. This will VOID the warranty of the fireplace.**
21. Never spray or apply any type of sealer, insulation, or other materials to the fireplace.

UL 127 Listing Label



Intertek
W/N 04895
DO NOT REMOVE
OR COVER
THIS LABEL

MODULAR REFRACTORY FIREPLACE

STANDARD: 36" 42" 46"
80S36 80S42 80S46

CERTIFIED TO: UL 127, ULC S610

WHI-

ISOKERN

MADE IN USA
Chesapeake, VA 23323

Headquarters
Jacksonville, FL 32256

CLEARANCE TO COMBUSTIBLES:

SMOKE DOME FRONT AND ISOKERN CHIMNEY	= 0 in.
UNIT SIDES AND REAR	= 1.5 in. (38mm)
COMBUSTIBLE SHEATHING ABOVE OPENING	= 8 in. (203mm)
TOP SHEATHING OR TRIM TO OPENING SIDES	= 8 in. (203mm)
MANTEL ABOVE OPENING	= 14 in. (356mm)
OPENING TO SIDEWALL	= 26 in. (660mm)
HEARTH EXTENSION BEYOND FRONT	= 20 in. (508mm)
HEARTH EXTENSION BEYOND SIDES	= 12 in. (305mm)
COMBUSTIBLE FLOOR (MUST USE FIRE-LITE APPLICATION)	= 4 in. (102mm)
INSULATION FROM FIREBOX	= 3 in. (76mm)

USE SOLID WOOD FUEL OR LISTED DECORATIVE GAS VENTED OR UNVENTED APPLIANCE. ALSO FOR USE WITH LISTED METAL CHIMNEY. FIRE-LITE APPLICATION TO USE ECO-STEEL CHIMNEY ONLY.

DO NOT USE A FIREPLACE INSERT OR OTHER PRODUCTS NOT SPECIFIED FOR USE WITH THIS PRODUCT. "WARNING" THIS FIREPLACE HAS NOT BEEN TESTED FOR USE WITH GLASS DOORS. TO REDUCE THE RISK OF FIRE OR INJURY, DO NOT INSTALL GLASS DOORS. IF DOORS ARE USED, OPERATE FIREPLACE WITH DOORS FULLY OPEN. WHEN BURNING A DECORATIVE GAS APPLIANCE IN THE FIREPLACE, LOCK THE DAMPER TO THE FULLY OPEN POSITION. DO NOT OPERATE AN UNVENTED GAS LOG SET IN THIS FIREPLACE WITH THE CHIMNEY REMOVED.

SEE INSTALLATION AND OPERATING INSTRUCTIONS FOR THIS MODEL AND ICC # ESR-2316,

CONTACT BUILDING OFFICIAL PRIOR TO INSTALLATION
REFER TO INTERTEK'S DIRECTORY OF BUILDING PRODUCTS FOR DETAILED INFORMATION.

The latest revision of this manual may be obtained at the Earthcore website:

<https://www.earthcore.com/installation-manuals/>

OR

Scan this QR code



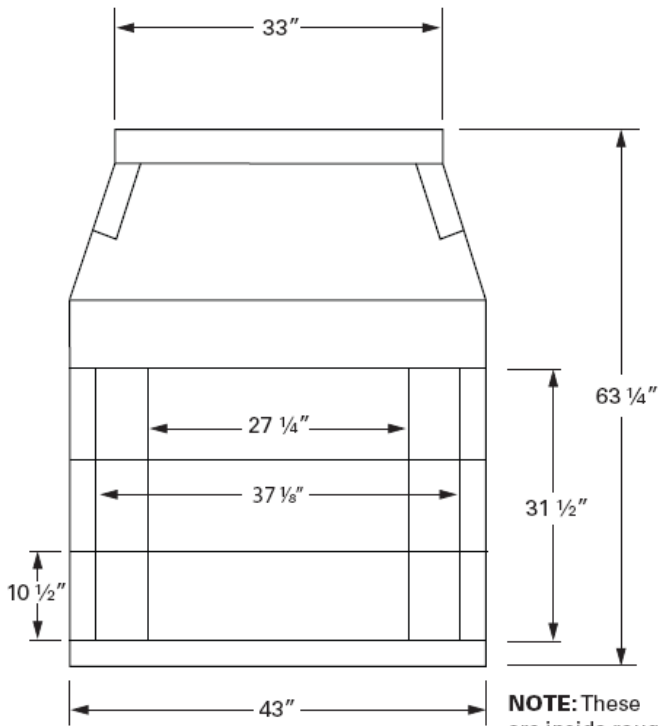
Isokern Fireplace and Chimney Systems are tested and listed to UL standards: UL 127, ULC S610, and UL 103HT. The listing label shown above outlines the listed clearances to combustibles and indicates that the units are suitable for use with solid fuel or listed gas appliances. Refer to the manufacturer's installation manual for detailed description of clearances to combustibles and all other installation information.

A metal listing label similar to those shown above is affixed to each fireplace. Do not remove the listing label from the fireplace.

Prior to beginning installation, contact your local building official to determine the need to obtain a permit

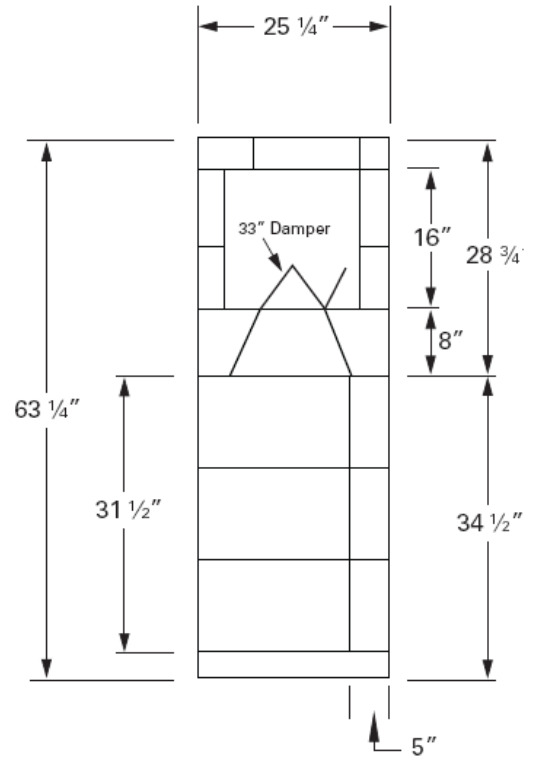
STANDARD 36 (80S36)

CAUTION: When using the Isokern brick ledge it is required that the firebox/smoke dome assembly include the placement of a 4" x 4" x 3/8" minimum steel angle across the firebox opening.

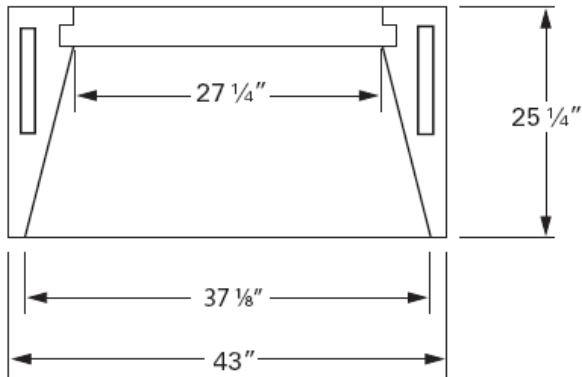


Front View

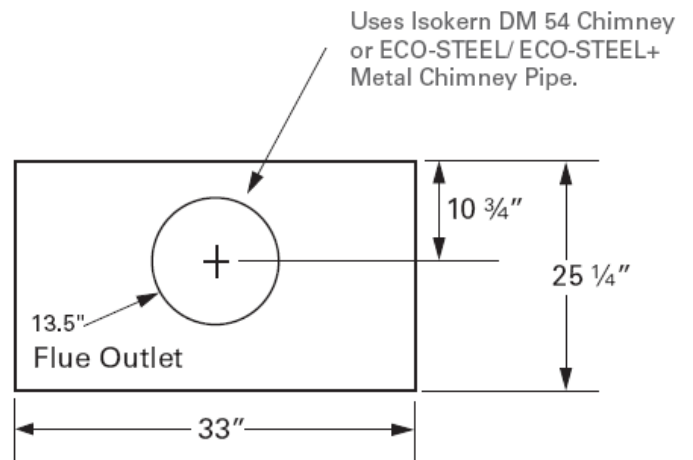
NOTE: These are inside rough dimensions before firebrick



Side View

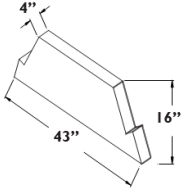
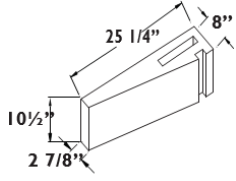
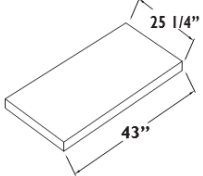
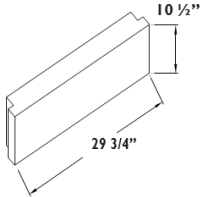
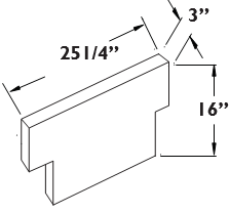
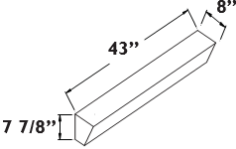
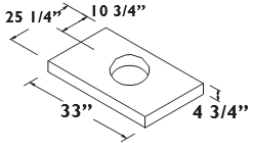
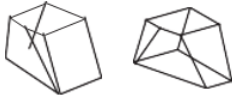


Plan View



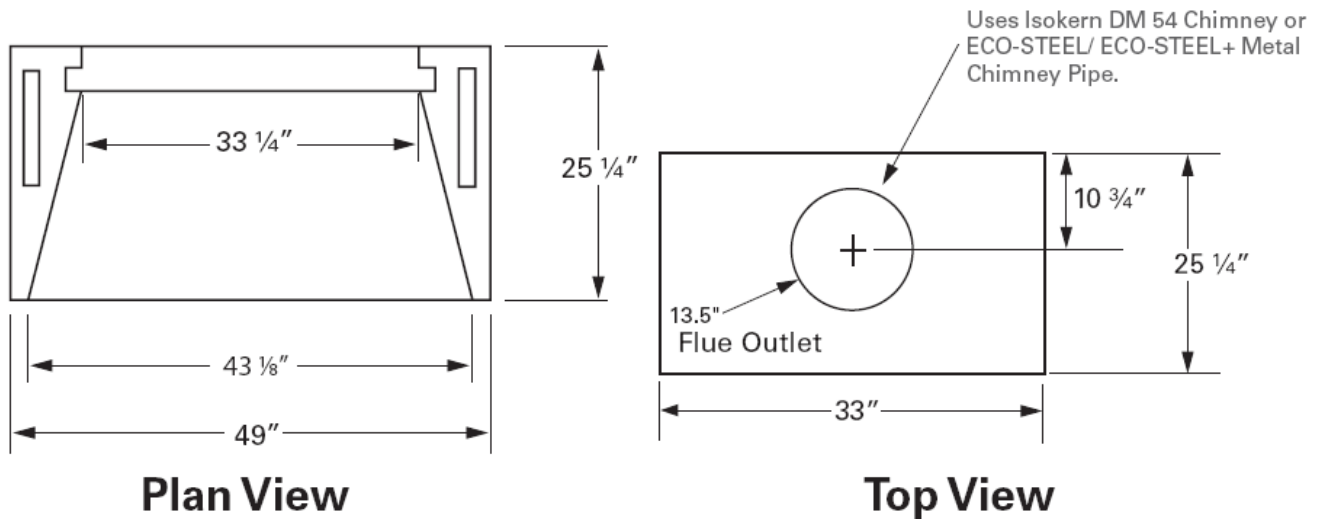
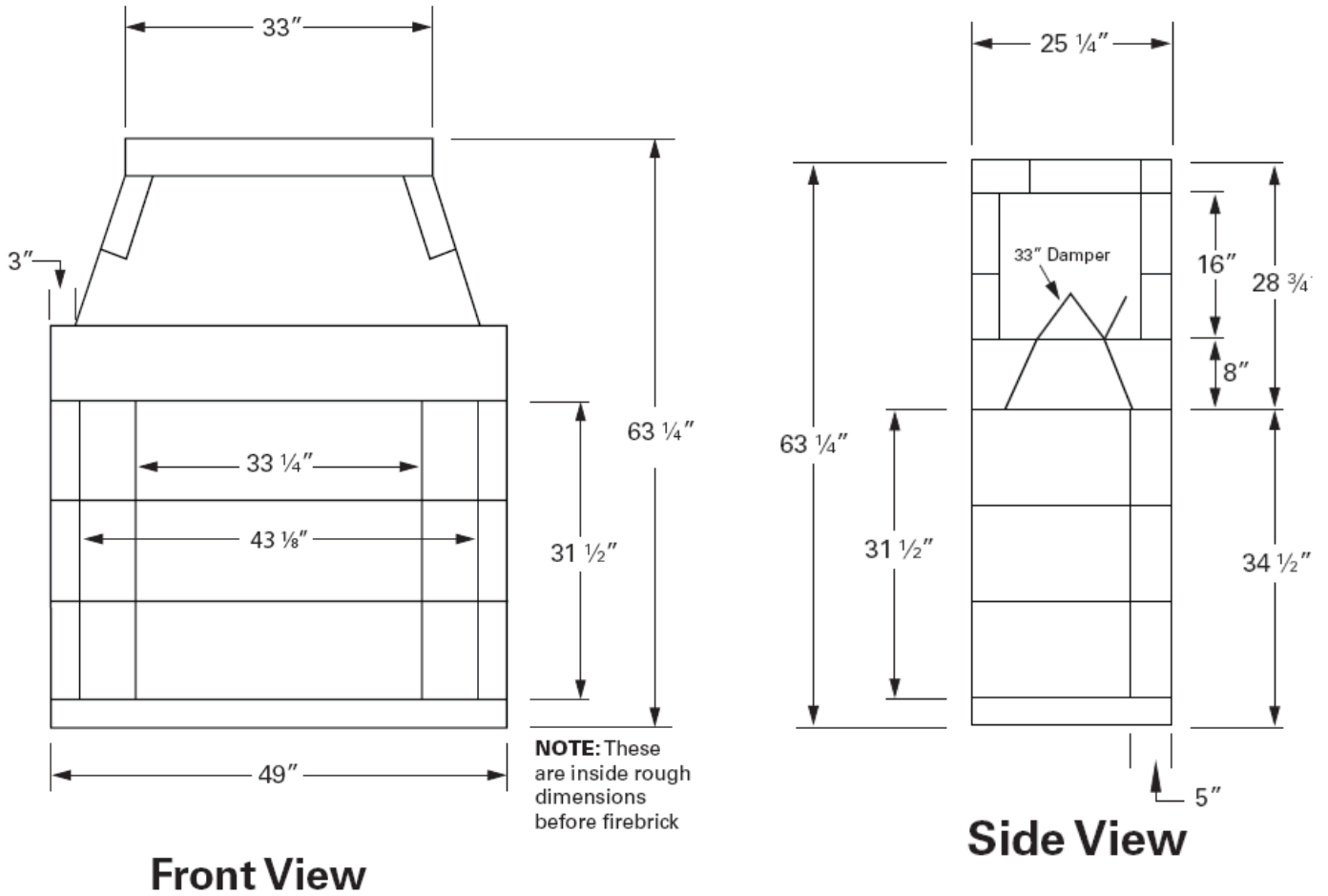
Top View

Component List - STANDARD 36 (80S36)

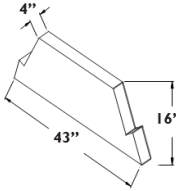
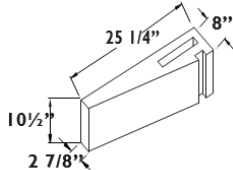
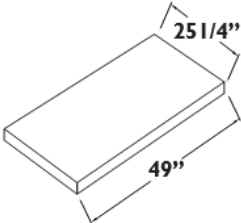
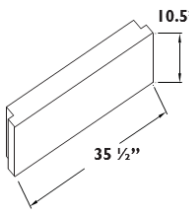
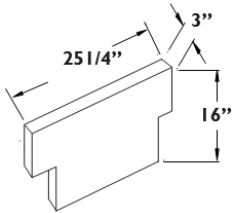
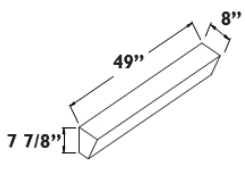
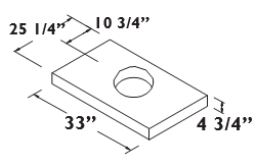
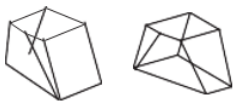
Component	Part#	Description
 <p>Technical drawing of a smoke dome with dimensions: 43" length, 16" height, and 4" top width.</p>	11	Isokern STANDARD Smoke Dome (Qty 2)
 <p>Technical drawing of a sidewall with dimensions: 25 1/4" length, 10 1/2" height, 2 7/8" thickness, and 8" top width.</p>	20	Isokern STANDARD Sidewall (Qty 6)
 <p>Technical drawing of a base plate with dimensions: 43" length and 25 1/4" width.</p>	21	Isokern STANDARD Base Plate
 <p>Technical drawing of a backwall with dimensions: 29 3/4" length and 10 1/2" height.</p>	25	Isokern STANDARD Backwall (Qty 3)
 <p>Technical drawing of a side sloping piece with dimensions: 25 1/4" length, 16" height, and 3" top width.</p>	34	Isokern STANDARD Side Sloping (Qty 2)
 <p>Technical drawing of a damper beam with dimensions: 43" length, 7 7/8" height, and 8" top width.</p>	M68	Isokern STANDARD Damper Beam Front & Rear (Qty 2)
 <p>Technical drawing of a top plate with dimensions: 33" length, 4 3/4" height, 25 1/4" width, and 10 3/4" width for the central opening.</p>	M77	Isokern STANDARD Top Plate
 <p>Technical drawings of damper end pieces, left and right views.</p>	95L & 95R	Isokern STANDARD Damper End Left & Right

STANDARD 42 (80S42)

CAUTION: When using the Isokern brick ledge it is required that the firebox/smoke dome assembly include the placement of a 4" x 4" x 3/8" minimum steel angle across the firebox opening.

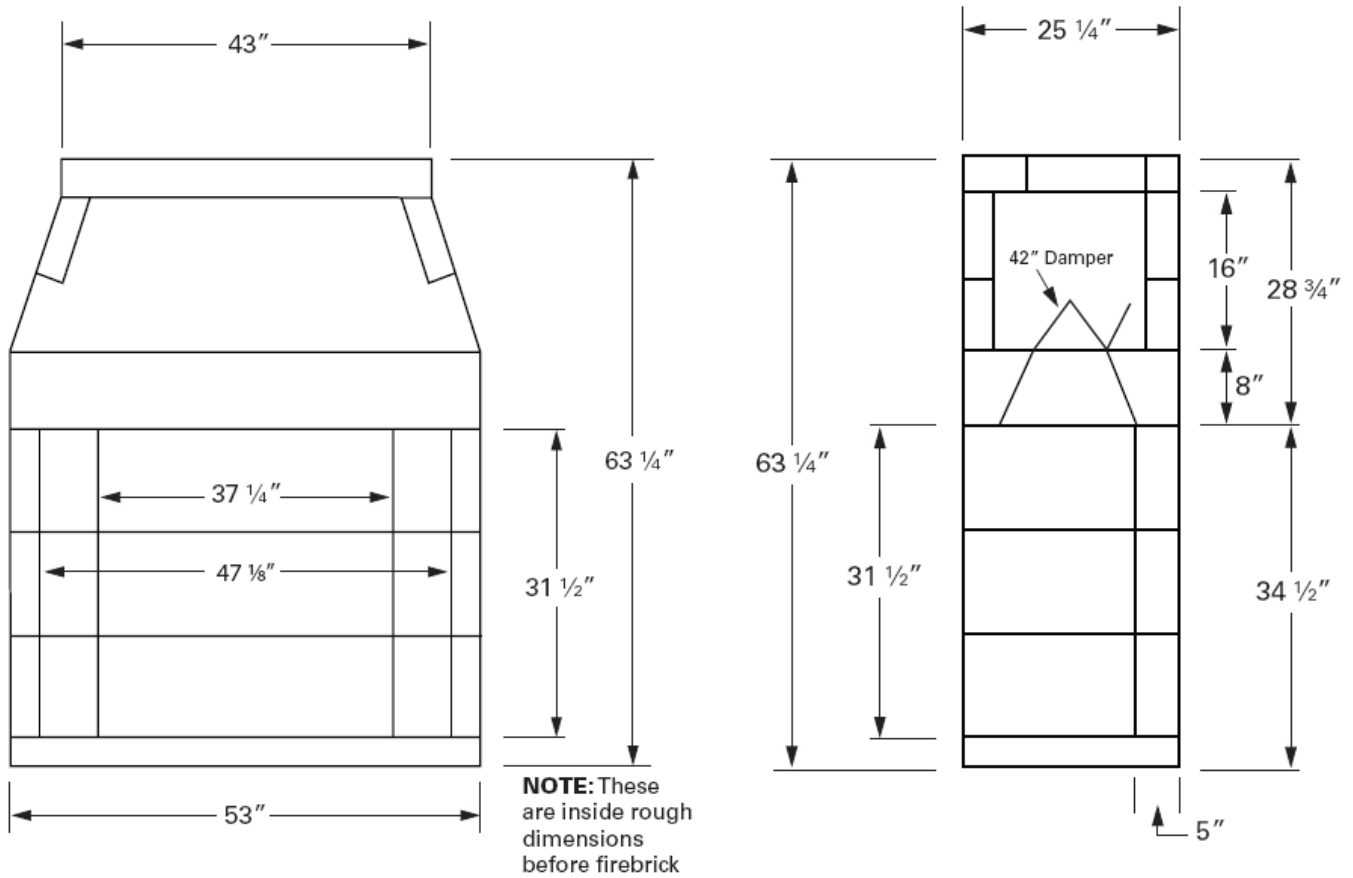


Component List - STANDARD 42 (80S42)

Component	Part#	Description
	11	Isokern STANDARD Smoke Dome (Qty 2)
	20	Isokern STANDARD Sidewall (Qty 6)
	22	Isokern STANDARD Base Plate
	28	Isokern STANDARD Backwall (Qty 3)
	34	Isokern STANDARD Side Sloping (Qty 2)
	M69	Isokern STANDARD Damper Beam Front & Rear (Qty 2)
	M77	Isokern STANDARD Top Plate
	95L & 95R	Isokern STANDARD Damper End Left & Right

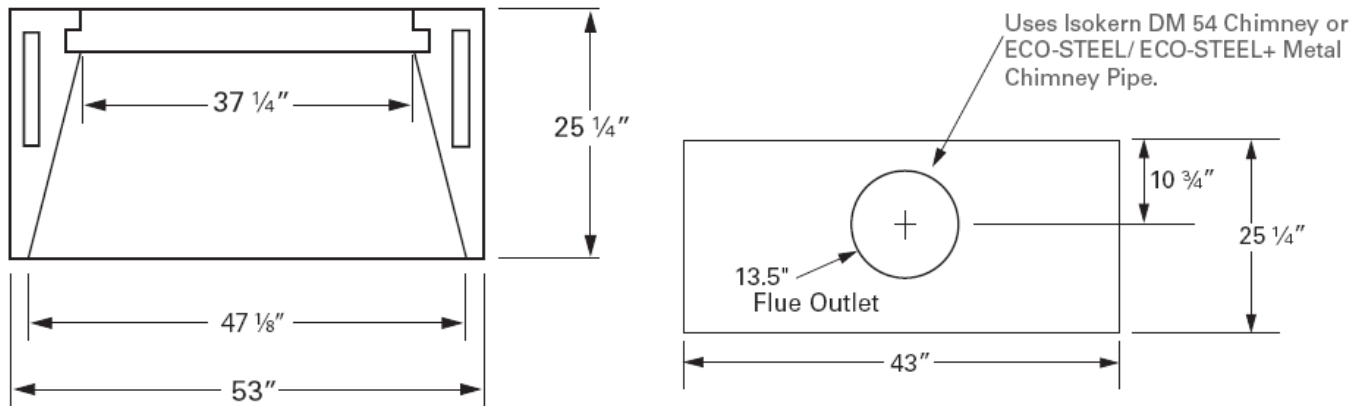
STANDARD 46 (80S46)

CAUTION: When using the Isokern brick ledge it is required that the firebox/smoke dome assembly include the placement of a 4" x 4" x 3/8" minimum steel angle across the firebox opening.



Front View

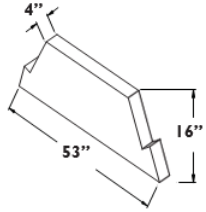
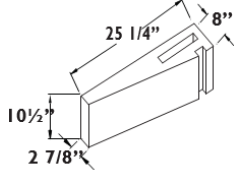
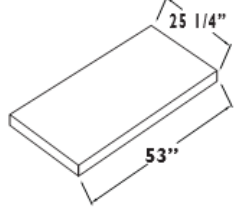
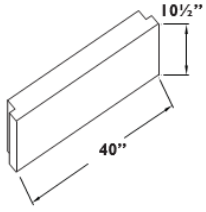
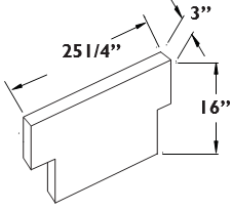
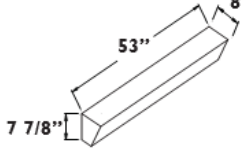
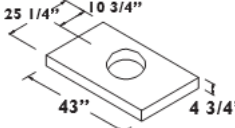

Side View



Plan View

Top View

Component List - STANDARD 46 (80S46)

Component	Part#	Description
 <p>Technical drawing of a smoke dome with dimensions: 4" (width), 53" (length), and 16" (height).</p>	13	Isokern STANDARD Smoke Dome (Qty 2)
 <p>Technical drawing of a sidewall with dimensions: 25 1/4" (length), 8" (width), 10 1/2" (height), and 2 7/8" (thickness).</p>	20	Isokern STANDARD Sidewall (Qty 6)
 <p>Technical drawing of a base plate with dimensions: 25 1/4" (length) and 53" (width).</p>	23	Isokern STANDARD Base Plate
 <p>Technical drawing of a backwall with dimensions: 10 1/2" (height) and 40" (length).</p>	31	Isokern STANDARD Backwall (Qty 3)
 <p>Technical drawing of a side sloping piece with dimensions: 25 1/4" (length), 3" (width), and 16" (height).</p>	34	Isokern STANDARD Side Sloping (Qty 2)
 <p>Technical drawing of a damper beam with dimensions: 53" (length), 7 7/8" (width), and 8" (height).</p>	M70	Isokern STANDARD Damper Beam Front & Rear (Qty 2)
 <p>Technical drawing of a top plate with dimensions: 25 1/4" (length), 10 3/4" (width), 43" (length), and 4 3/4" (width).</p>	M81	Isokern STANDARD Top Plate
 <p>Technical drawing showing two damper end pieces, labeled 95L and 95R.</p>	95L & 95R	Isokern STANDARD Damper End Left & Right

Required Clearance to Combustibles

The STANDARD Series fireplace and the DM chimney system is tested and listed for installation with “clearance to combustibles” as follows:

- DM 54 Outer Casing components chimney is 0” clearance (**Figure 1**).
- The STANDARD Series firebox side walls and back wall require 1-1/2” clearance. (**Figure 2**)
- The smoke dome front wall requires 0” clearance.

NOTE: “Combustibles” are defined as “normal construction materials” and are considered to be wood framing materials, particle board, mill board, plywood sub-flooring, plywood paneling and wood flooring.

STANDARD Series fireplaces are tested and listed for (1-1/2”) clearance to combustible framing material at the firebox sides and back.

Installation and use practices that are beyond the control of the manufacturer* can result in situations where clearance requirements (as determined through testing and as stated by the manufacturer) are not maintained due to construction after the installation of the Isokern unit. It is the general contractor’s responsibility to assure that listed clearances to combustible framing and to insulation are maintained throughout the construction of the project after the installation of the Isokern unit.

To avoid causing a fire resulting in damage to property, personal injury, or loss of life, do not pack or fill the required air spaces with insulation or other material. No material is allowed in these areas. (**Figures 2 & 3**)

Keep all insulation, vapor barriers, “house wrap” paper and other insulating type membranes and products, including fiberglass, cellulose and other insulation, (anything that carries an “R” rating) a minimum of three inches (3”) away from all firebox and chimney surfaces.

FIGURE 1

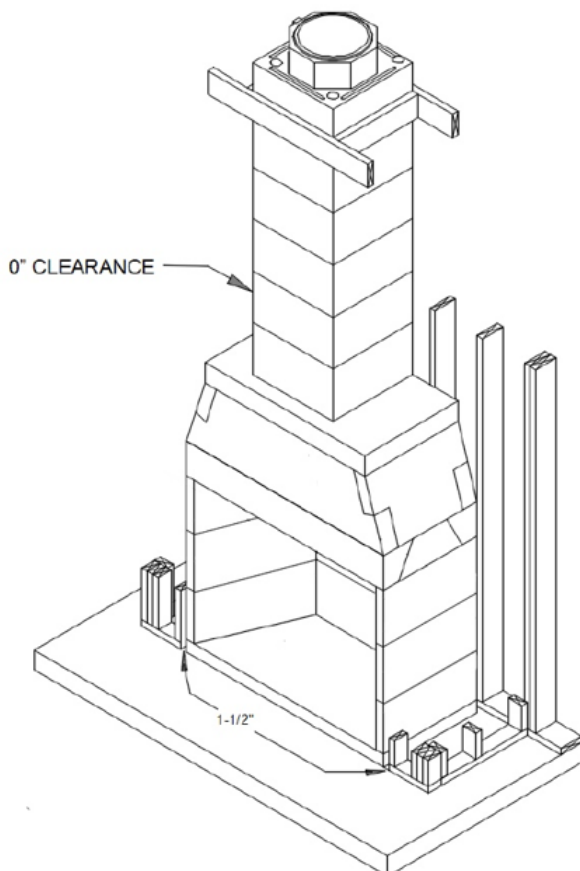
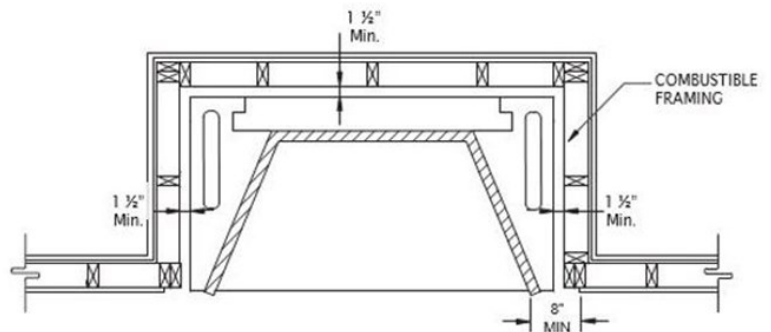


FIGURE 2



Required Clearance to Combustibles

IMPORTANT: The manufacturer is not responsible for installation and use practices that are beyond the scope of the product as defined in the product listing and in this installation manual.

Sheathing materials, such as plywood, particle board, and drywall, may cover the smoke dome front at 0" clearance.

All combustible sheathing materials that protrude beyond front of firebox:

Models 36, 42, and 46 (see Figure 2):

- Sides: 8" away
- Top of opening: 8" away

Drywall must be cut back from the firebox opening sides and above the top of the opening according to information above.

EXCEPTION: If insulation is used in walls surrounding the fireplace, insulation may be installed behind sheathing of gypsum board, plywood, particle board or other material on the side facing the Isokern. The facing material cannot be within 1-1/2" to the fireplace side walls.

The STANDARD Series fireplace must sit upon a concrete support slab designed to bear the total installed weight of the fireplace and DM chimney system. These support slabs can have no wood underpinnings (**Figure 3**). See **page 16** for more information on weight loads.

Concrete support slabs for STANDARD Series fireplaces must provide the non-combustible hearth extension substrate needed to support the code required non-combustible hearth extension finish materials (**Figure 4**).

All STANDARD Series fireplaces shall have hearth extensions of approved non-combustible material such as brick, tile, or stone that is properly supported and with no combustible material against the underside thereof. This noncombustible hearth extension shall be set tight against the fireplace front and extend at least 20 inches out from the finished fireplace and at least 12" beyond the finished sides of the fireplace opening. Wooden forms used during the construction of hearths and hearth extensions must be removed when the construction is complete.

If a raised fireplace floor and raised hearth extension are preferred, the raised underlying structure must be built of non-combustible material, be structurally designed to hold the weight of the fireplace and chimney system and must sit on non-combustible substrate.

FIGURE 3

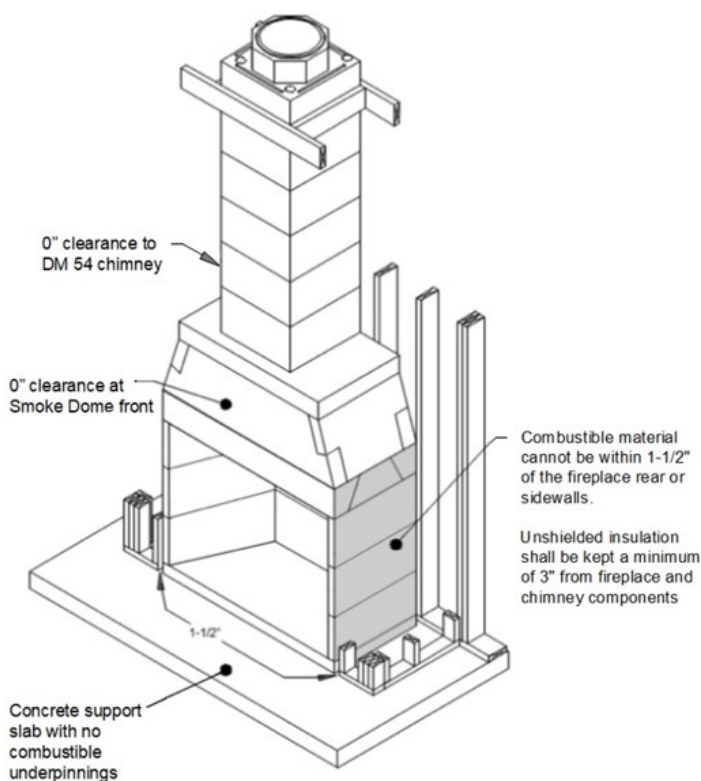
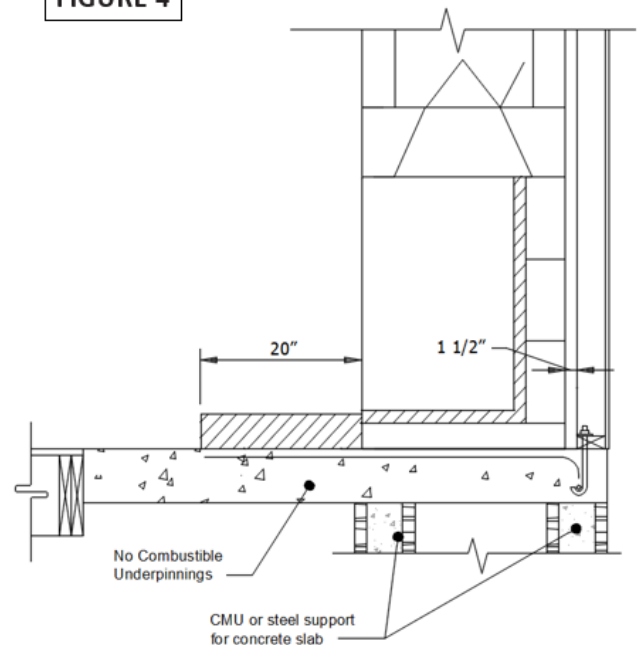


FIGURE 4



Supporting Floor System

The STANDARD 36, 42, and 46 Fireplaces are not rated for installation on a combustible floor system unless used in the Fire-Lite Application (see Page 17-19). Fireplaces must be built upon a concrete support slab with no wood underpinnings. Proper reinforced concrete support slab for fireplace installations may include the following types:

1. Slab on grade: standard residential, minimum four-inch (4") thick, 2500 psi concrete foundation on properly compacted fill. This type of foundation can support Isokern installations up to thirty feet (30')* overall height without additional structural support. (Brick ledge installations not included) (**Figure 5**).

* Minimum height. See page 3 for specific models.

2. Slab-on-grade foundations thickened and reinforced: for additional load carrying (**Figure 6**).
3. Off-grade slab on foundation walls and footings. Projects with off-grade floor systems as well as upper story installations require this type of support. When building off-grade support slabs the code required hearth extension substrate should be built as a continuation of the support slab for the fireplace unit (**Figure 7**). Supports for off grade slabs must be concrete or steel and capable of supporting the slab, Isokern unit and the chimney.

For multi-floor and back-to-back installations, proper weight computation on an individual basis is required. Consult a local structural engineer for load bearing requirements.

IMPORTANT: Foundations and footings must meet local code and be approved by the local building authority. For any foundation design and load requirements check with a local structural engineer. **It is the responsibility of the General Contractor to ensure adequate foundations.**

Fireplace weights* and "footprint" areas: The total fireplace weight and footprint for each model listed below includes Fireplace pumice components only:

STANDARD 36: 1200 lbs. @ 43" x 25" = 7.5 sq.ft.

STANDARD 42: 1325 lbs. @ 49" x 25" = 8.5 sq.ft.

STANDARD 46: 1450 lbs. @ 53" x 25" = 9.2 sq.ft.

***WEIGHTS BASED ON ISOKERN COMPONENTS ONLY.
EXCLUDES FIREBRICK, VENTING, AND ACCESSORIES.**

"Footprint" areas listed above are base plate dimensions for each model and are exclusive of code required hearth extension areas. See page 51 for hearth extension dimensions.

NOTE: Additional support slab area may be required at the side or back of the STANDARD unit to provide bearing for structural supports to a DM offset chimney sequence. (See pages 30-32 for offset chimney support requirements.)

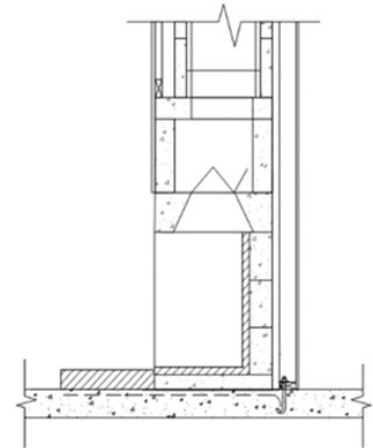


FIGURE 5

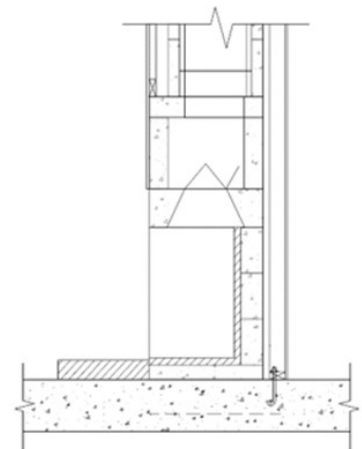


FIGURE 6

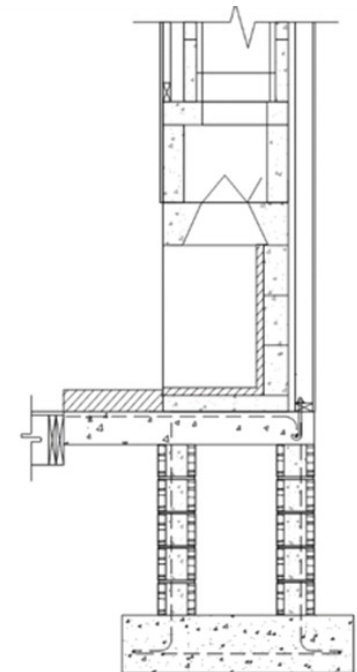
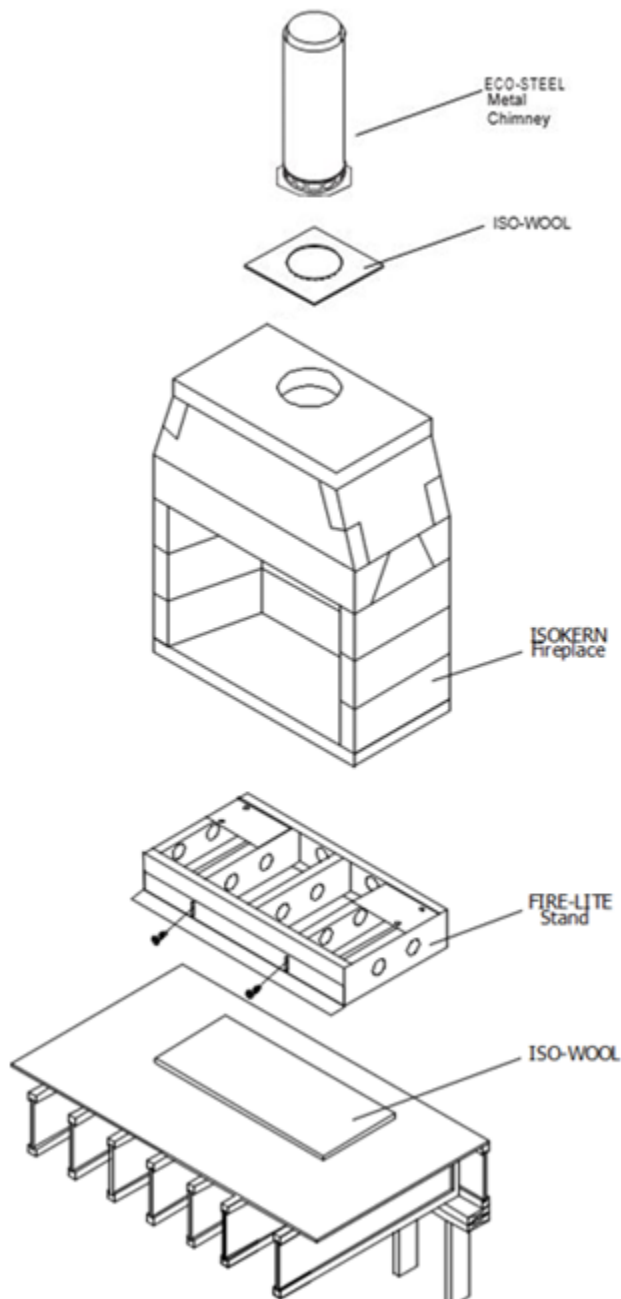


FIGURE 7

Fire-Lite Application

FIGURE 8



General Information:

The Fire-Lite is an application of the Isokern STANDARD 36, 42, and 46 fireplaces and is designed, tested, and listed with the ability to be installed on a combustible floor system. The design and installation require that the system use ECO-STEEL or ECO-STEEL+ metal chimney. The Isokern Fireplaces must sit on the Fire-lite stand using the applicable Fire-Lite kit.

The following pages will refer to installation requirements specific to the Fire-Lite application using the Isokern Metal Fire-Lite Stand.

Intended Use Statement:

The Fire-Lite Application of the Isokern fireplace is designed to sit on a combustible floor system and is intended to burn solid wood fuel, propane, or natural gas. The fireplace is intended for use as a supplemental heat source only and is not intended for heavy use as a primary heating system.

The Fire-Lite has been tested and listed by Warnock Hersey (Report Nos. J20004277-231 and 632-912500) to UL 127-

1999. These units are intended for installation in residential homes, and other buildings of conventional construction.

Fire-Lite Application of the Isokern fireplace are also designed for installation in accordance with the National Fire Protection Association Standard for chimneys, fireplaces, vents, and Solid Fuel-Burning Appliances (NFPA 211).

Clearance to Combustibles:

The Fire-Lite is tested and listed for installation with “clearance to combustibles” as follows:

1. Four-inch (4”) clearance to the combustible floor.
2. Zero-inch (0”) clearance at the Isokern smoke dome front wall.
3. One and one half-inch (1-½”) clearance at the Isokern firebox backwalls and side walls.
4. Two-inch (2”) minimum air space to combustibles at all ECO-STEEL or ECO-STEEL+ metal chimney.

IMPORTANT: “Combustibles” are defined as “normal construction materials” and are considered to be wood framing materials, particle board, mill board, plywood sub-flooring, plywood paneling, and wood flooring. Sheathing materials such as plywood, particle board, and drywall, may cover the smoke dome front at zero-inch (0”) clearance.

EXCEPTION: If insulation is used in walls surrounding the fireplace, insulation may be installed behind sheathing of gypsum board, plywood, particle board or other material on the side facing the Isokern. This facing material shall not be within 1-1/2” of the Isokern side or backwalls

IMPORTANT: The Fire-Lite Application is designed, tested and approved for installation at a minimum of four inches (4”) above combustible floor systems per the installation specifications given in this manual.

Fire-Lite Application

All portions of the combustible floor system under the Fire-Lite stand are to be covered with minimum 1/2" thick ceramic fiber Isowool or equivalent rated to 2100 degrees Fahrenheit (**Figure 9**).

Use of Insboard cut-out underneath the Fire-Lite stand is still an accepted installation practice (**Figure 9**).

All Fire-Lite Application of the Isokern fireplace result in the finished fire brick floor of the firebox being at least eight inches (8-1/2") above the combustible floor system (**Figure 9**).

The non-combustible raised platform must be set with a minimum one and one half one-and-one-half inch (1-1/2") clearance to the wall to the sides and directly behind the Fire-Lite assembly.

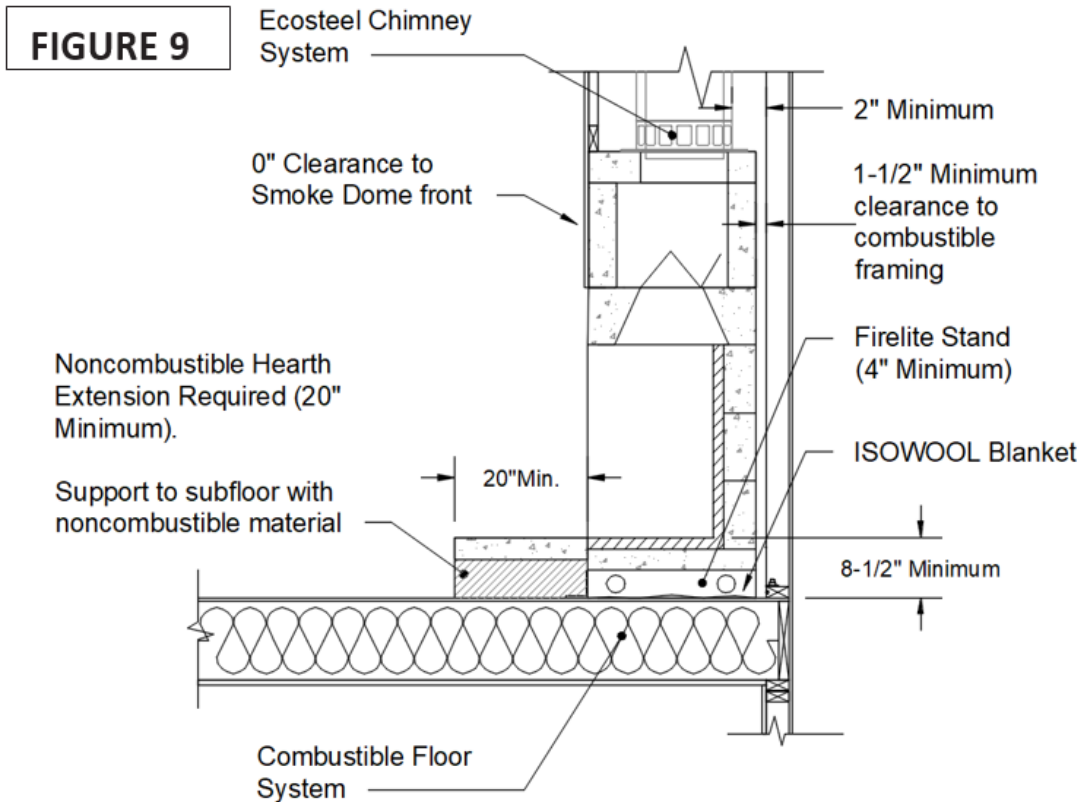
Raised Platform: Nominal four-inch (4") metal base (**Figure 9**). Set the Fire-Lite base plate in Earthcore Adhesive on to the non-combustible raised platform.

IMPORTANT: Metal safety strip - a metal angle is attached to the Fire-Lite stand when shipped. This angle is to be removed before installation, turned over and re-attached to the metal stand so that the 2" lip faces forward of the metal stands. This creates a metal safety strip and can be adjusted to ensure your metal stand, set on top of the Isowool will be level. The safety strip must extend out from the front of the raised platform at least two inches (2")

The exposed combustible floor underneath the non-combustible raised platform must be completely covered with Isowool ceramic fiber insulation (**Figure 9**). The Isowool is dry-laid to the floor within the block perimeter.

The ceramic fiber must have a thermal conductivity rating equal to or greater than 0.4 Btu-in/(hr. sq. ft-degree Fahrenheit). (Reference: Harbison-Walker, 600 Grant St., Pittsburgh, PA 15219, ph. 412-562-6200: "Insboard 2100" or equivalent.)

Firebrick Installation: Follow instructions on page 49 of this manual.



*Height based on the use of 1-1/4" firebrick and a 1/4" mortar bed. This height may vary based on the firebrick used.

Fire-Lite Application

Recessed Fire-Lite: If the design preference is for a flush hearth Fire-Lite application (floor of the fireplace at the same level the room’s floor), with advanced planning, the metal stand can be lowered, set, and attached to the joist system (**Figure 10 and 11**).

NOTE: For seismic anchorage design and instructions of the flush hearth application, please contact the Technical Department 1-800-642-2920.

When calculating flush hearth height, be sure to allow for the four (4”) metal stand, three-inch (3”) thick base plate plus the one and one half-inch (1-½”) thick fire brick floor.

IMPORTANT: Whether a flush hearth is preferred or a raised hearth, the Firelite application requires that the combustible floor in front of the fireplace must be covered with a non-combustible hearth extension set tight against the fireplace front and extend at least 20” out from the finished fireplace and at least 12” beyond the finished sides of the fireplace opening. (**Figure 11**)

For all “Fire-Lite” construction, it is necessary to use the base plate and the metal Fire-Lite stand. Be sure to secure the Fire-Lite metal stand to the floor framing system.

NOTE: Field verified dimensions should make allowance for hearth extensions in front (20”) and sides (12” ea.) from the fireplace opening. Also, make sure fireplace sides and rear have 1-½” clearance to combustibles.

Part#	Description
MS-S-36	STANDARD 36 Fire-lite Kit (Stand w/ ISOWOOL) 4" x 46" x 25"
MS-S-42	STANDARD 42 Fire-lite Kit (Stand w/ ISOWOOL) 4" x 49" x 25"
MS-S-46	STANDARD 46 Fire-lite Kit (Stand w/ ISOWOOL) 4" x 53" x 25"

FIGURE 10

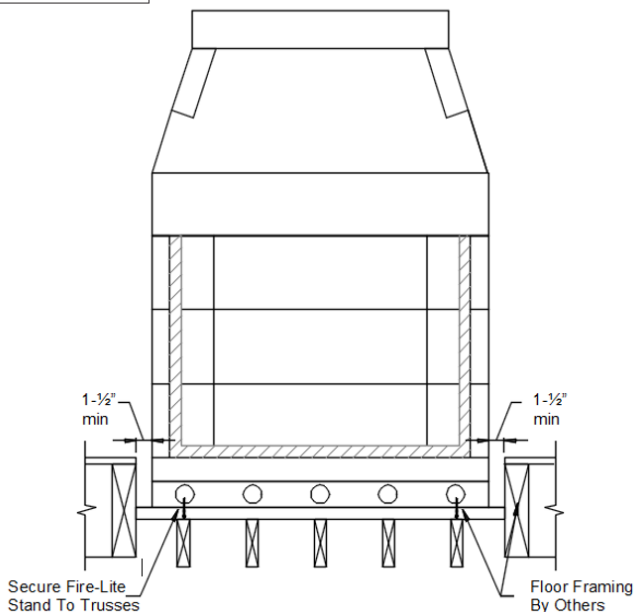
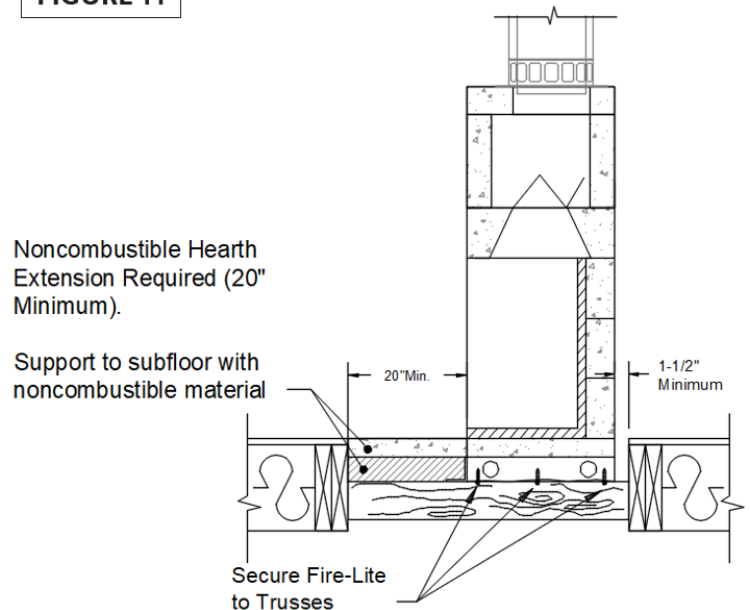


FIGURE 11



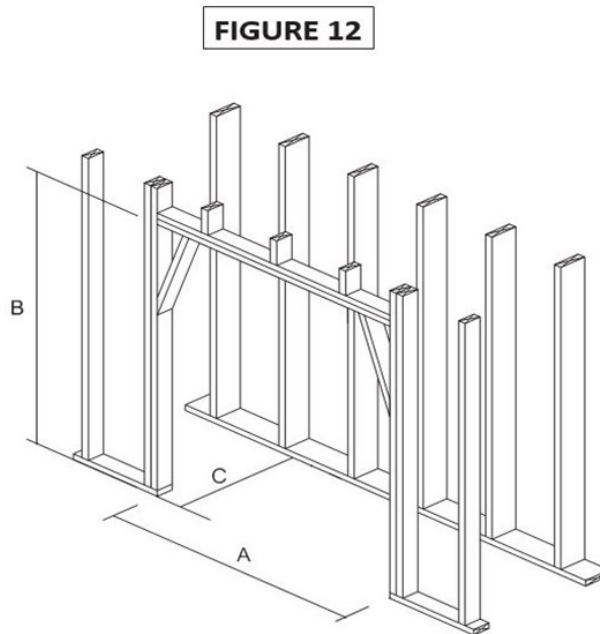
Rough Framing Dimensions

Typical Installation Framing Dimensions

MODEL	WIDTH - A	HEIGHT-B	DEPTH-C
80S36	46"	65"	26 3/4"
80S42	52"	65"	26 3/4"
80S46	56"	65"	26 3/4"

NOTES:

1. "B" includes the 3"-thick base plate.
2. "Raised hearth" requires additional rough opening height at "B" equal to the height of the raised hearth detail.
3. Rough framing dimension for width "A" allows for the required 1-1/2" clearance at the sides of the Fireplace.
4. Rough framing dimension for Height "B" will need to be increased by 4" if the FIRE-LITE application is utilized.
5. Rough framing dimension for depth "C" allows for the required 1-1/2" clearance at the back of the fireplace. Note that this 26-3/4" is typically used on interior walls that do not have insulation present.



IMPORTANT: Unless the insulation on an exterior wall is installed behind plywood sheathing, a depth of 28-1/4" is often used to account for the required 3" clearance to insulation. Even with this increased distance, the installer should be aware that spray foam insulation may expand past the face of the stud wall and will require trimming prior to firebox installation to maintain the required 3" clearance. It is important that any insulation that is not installed behind sheathing shall be installed in such a manner that it cannot fall on the firebox and encroach on this clearance.

Corner Installation Framing Dimensions

The following chart of dimensions detail the positioning of STANDARD Series fireplace in a corner. It also details the positioning of DM chimney where it must turn 45° degrees if alignment is needed to overhead framing (**Figure 13**).

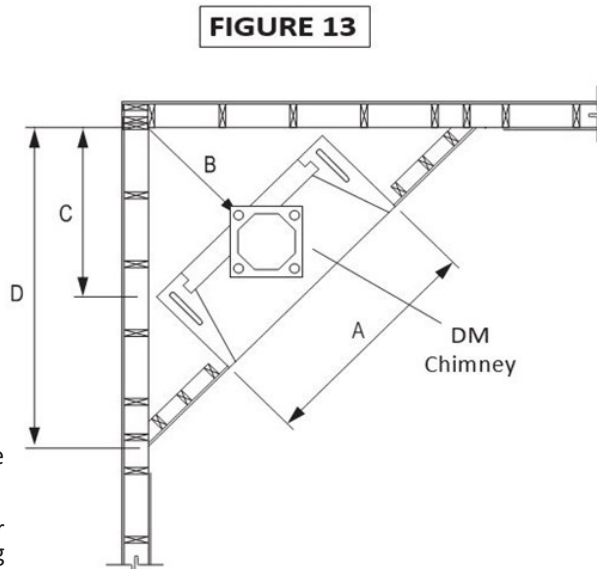
MODEL	A	B	C	D
80S36	46"	23-1/2"	32"	69"
80S42	52"	26-1/2"	35-1/2"	73"
80S46	56"	28-1/2"	39"	76"

To turn flue 45°, first set starting inner liner onto the top plate of the fireplace.

Next, set a DM outer casing onto the inner liner so that the outer casing is at 45° to the firebox and square to the overhead framing system. Run the vertical DM chimney through the overhead framing.

Offset blocks can be used, if necessary, to align with overhead framing before running the vertical DM chimney outer casing and liner.

NOTE: Support the third offset down to footings and at each third offset block thereafter. Always support the last offset block in a sequence for full support of the DM chimney where it returns to vertical.



General Assembly Instructions

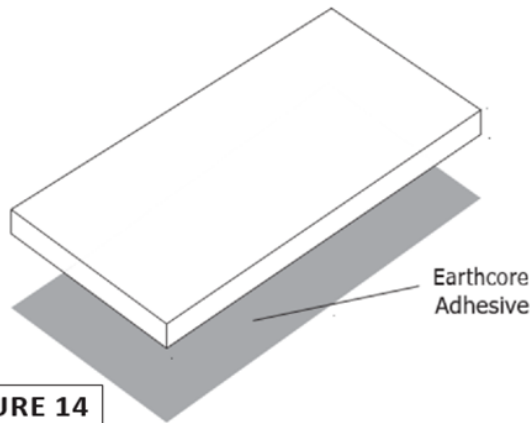


FIGURE 14

When beginning the assembly process, mix the Earthcore Adhesive with clean water to a smooth, workable texture (without lumps or dry pockets) of a “toothpaste” consistency. This mixture is suitable for application onto Isokern components by using a masonry grout bag supplied with the unit.

Attention should be paid that the Earthcore Adhesive mixture is not too thin or runny, as this will not allow the Earthcore Adhesive to reach its maximum bonding strength.

Mark out the position of the base plate on the supporting floor system. Apply a thin layer of Earthcore Adhesive to the area and set base plate in the mortar (**Figure 14**).

Earthcore Adhesive is then squeezed from a grout bag onto the contact surfaces of the Isokern components as they are fitted together.

NOTE: It is important that a 1/2” bead of Earthcore Adhesive is piped onto all the components’ contact surfaces, about 1/2” in from all edges (**Figure 15**).

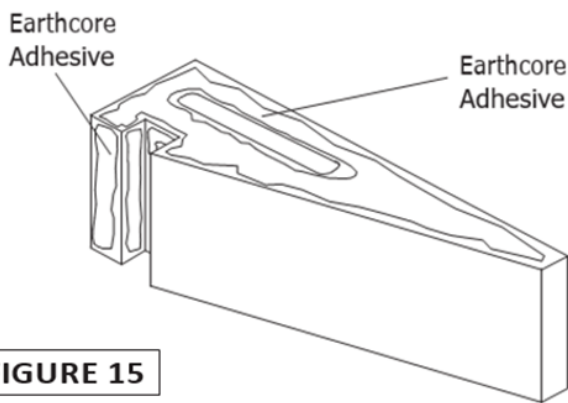


FIGURE 15

When setting the next component onto the Earthcore Adhesive contact surface of the base plate some Earthcore Adhesive should squeeze out along the face of the entire joint as a sign of complete and proper sealing of the joint. On broader contact surfaces, it is advisable to apply several additional 1/2” beads of the Earthcore Adhesive to the area to assure proper sealing of the joint.

When applied properly the firebox and smoke dome assembly should require approximately 100 pounds (dry measure) of Earthcore Adhesive.

Leveling and Aligning Components:

Be sure to assemble all Isokern components level and flush with adjoining components.

Earthcore Adhesive is not intended to create an Earthcore Adhesive joint of any thickness for leveling purposes.

Therefore, leveling and alignment adjustments are made using small plastic shims supplied with the unit (Figure 16).

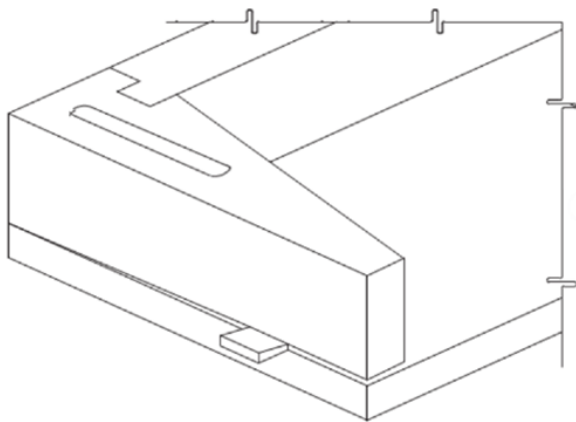


FIGURE 16

The shims can be inserted under a component to level and align it with adjacent Isokern components. Be sure to re-grout any and all gaps resulting from shim insertion to maintain components to full bearing.

Broken Components:

Components can be repaired by using Earthcore Adhesive along the break line as the component is set into place. Components broken into multiple small pieces should be discarded and replaced.

IMPORTANT:

1. Do not mix Earthcore Adhesive with anti-freeze agents.
2. The maximum recommended Earthcore Adhesive joint thickness at Isokern components is 1/4”.

Assembly Instructions - STANDARD Series 36, 42, & 46

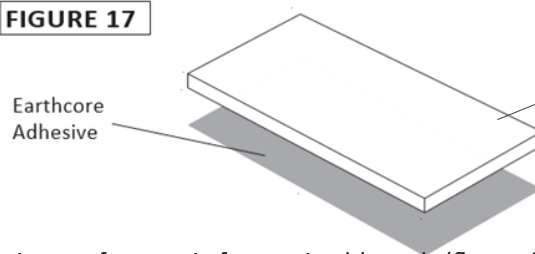
The following assembly instructions identify the parts by name, part number, and the placement of each part in the assembly process.

NOTE: At all component placement, be sure to apply Earthcore Adhesive to all contact surfaces. Check for complete sealing of each contact joint while assembly progresses..

1. Set the base plates in a full bed of Earthcore Adhesive on a level support surface. See **page 16** for supporting floor system (**Figure 17**). Do not set the base plate so that it is in span.

Flush Hearth: If the design preference is for a “flush hearth” the base plate can be omitted from the assembly, and the firebox walls can be built directly on a minimum 4" concrete support slab. The fire brick floor of the firebox is then set directly to the concrete support slab. This makes the fireplace finished fire brick floor approximately one-and-one-half inches (1-½") above the top of the concrete support slab.

FIGURE 17



BASE PLATE:

80S36	PART #21
80S42	PART #22
80S46	PART #23

Raised Hearth: If the design preference is for a raised hearth (floor of the fireplace elevated above the room’s floor), then the base plate can be set on a noncombustible platform that is built up to the desired raised hearth height on the concrete support slab.

When calculating raised hearth height be sure to allow for the three-inch (3”) thick base plate plus the one-and-one-half inch (1-½”) thick fire brick floor in addition to the height of the platform.

For all “raised hearth” construction where concrete blocks are used to create the raised platform, it is necessary to use the base plate. Be sure to adhesive the concrete block platform together. CMU used for base plate support should be rated ASTM 90.

Whether a flush hearth or a raised hearth is installed, all STANDARD Series fireplaces shall have hearth extensions of approved non-combustible material such as brick, tile, or stone that is properly supported and with no combustible material against the underside thereof . This noncombustible hearth extension shall be set tight against the fireplace front and extend at least 20 inches out from the finished fireplace and at least 12" beyond the finished sides of the fireplace opening.

2. Set the first course of the firebox sidewalls and backwalls into place (**Figures 18 & 19**)

NOTE: It may be convenient to dry set the first course of side walls and backwalls into place on the Isokern base plate, and then trace their position on the base plate with a pencil.

FIGURE 18

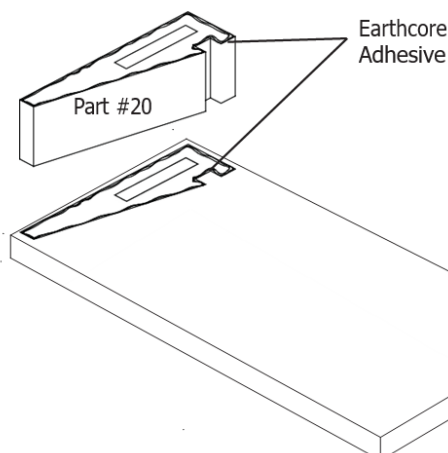
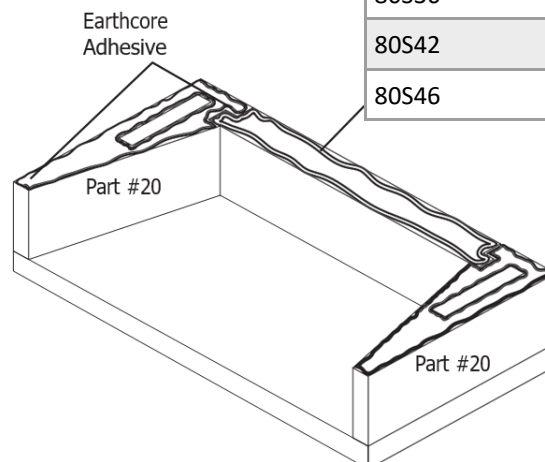


FIGURE 19



BACKWALL:

80S36	PART #25
80S42	PART #28
80S46	PART #31

Assembly Instructions - STANDARD Series 36, 42, & 46

After outlining the dry set pieces, remove them and apply Earthcore Adhesive to the areas traced on the base plate where the side walls and backwall are to sit. By doing this, the first layer of wall components can be set directly into Earthcore Adhesive already applied to the proper areas on the base plate.

3. Continue assembly of the consecutive courses of the firebox side wall and backwall. Apply adhesive to the top of each layer of wall components, set the next course above into place. Be sure to Earthcore Adhesive all vertical joints of the side wall to back wall connections when setting each component to its mate (**Figure 20**).

Look for some Earthcore Adhesive to squeeze out along the joints of all contact surfaces as a sign that the joint is thoroughly sealed with the approved Earthcore Adhesive.

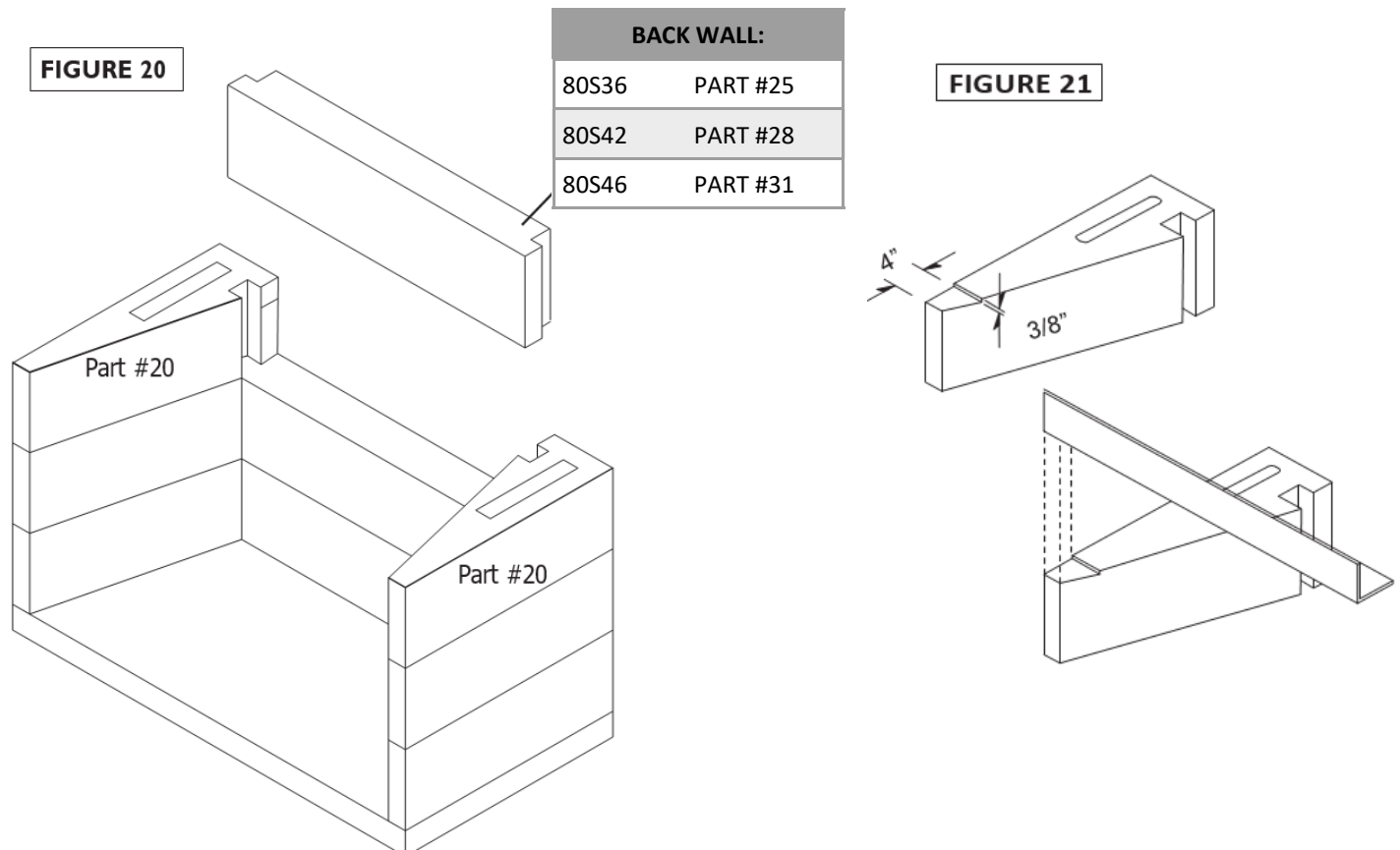
4. When all the firebox side wall and backwall components are set, check the top surface of the firebox for level. If necessary, adjust the top surface of the box assembly for level by inserting a shim supplied with the unit between the lowest wall component and the top surface of the base plate.

Any gap created under the wall components during the shim leveling process must be filled with Earthcore Adhesive to fill bearing against the base plate.

NOTE: If you are using DM Chimney or DM Chimney with a brick ledge, a steel angle iron should be utilized following these instructions.

CAUTION: When using the Isokern brick ledge, it is required that the firebox/smoke dome assembly include the placement of a 4" x 4" x 3/8" minimum steel angle across the fire opening. This item is not included in the components and can be sourced locally.

5. This steel angle sits on top of the uppermost side wall component with the four-inch leg in the horizontal position. To avoid a thickness problem with the placement of the steel angle, it is necessary to cut a notch in the top side wall component where the angle is to sit. This notch should be cut approximately 3/8" deep. The notch should start at the front face of the side wall component (at both the left-hand and right-hand walls) and run to a point 4" back toward the firebox (**Figure 21**).



Assembly Instructions - STANDARD Series 36, 42, & 46

The steel angle sits in this notch. The four-inch leg of the steel angle is in the vertical position and is to be in alignment with the front of the firebox. The ends of the steel angle should not protrude beyond the outer firebox side wall. Earthcore Adhesive between the steel and the notch in the top of the side wall is not needed.

6. The fireplaces come with an eight-inch (8") thick damper beam assembly, a 4-piece component group that is to be assembled on top of the firebox side walls and backwall.

The damper beam assembly consists of two (2) long lintel pieces and two (2) short damper beam side pieces.

The damper side pieces are designed to sit on the firebox side wall between the front lintel and the back lintel. Each of the damper side pieces is designed specifically for its own side of the unit. When properly set, each damper side piece fits flush with the outside face of the firebox side wall so that its interior bottom edge aligns with the interior angle of the firebox side wall that it sits on (**Figure 22**).

The two (2) lintels will be equal to the width of the fireplace model that they serve. Properly placed, the lintel is to sit on top of the firebox backwall and flush with it; the other lintel sits flush with the front of the firebox, spanning the firebox opening. These components both sit on their narrow base so that their beveled face points down and into the firebox interior (**Figure 23**).

Be sure to Earthcore Adhesive all damper beam components to the top surfaces of the firebox. Earthcore adhesive the contact surfaces of each damper side component where it meets the front and back damper beam lintel components.

NOTE: The firebox and smoke dome are designed to be fitted with a traditional cast iron, poker-style throat damper and placed on top of the damper beams during installation. In-line, bottom-mount, or chimney-top dampers are alternative options. The damper is not included with the firebox.

7. With the damper beams assembled together with Earthcore Adhesive, set the cast iron throat damper (unless another damper type is being used) on top of the damper beam and over the smoke chamber opening. The cast iron damper's operating plate should face toward the rear of the fireplace (**Figure 23**). The flange at all four sides of the cast iron damper should be supported by the damper beam's top surface.

Position the cast iron damper so that its front flange is approximately one inch (1") away from the inside face of the front smoke dome component (**Figure 24**).

Run a thin bead of Earthcore Adhesive around the four sides of the cast iron damper or tack the corners of the flange to avoid movement of the damper as it gets opened and closed.

FIGURE 22

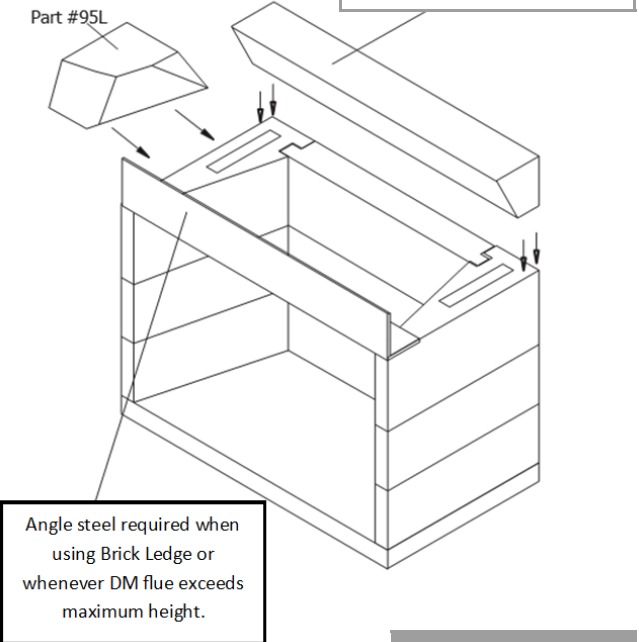


FIGURE 23

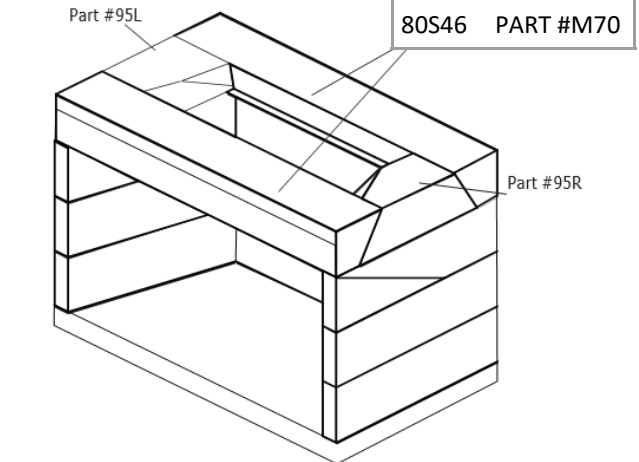
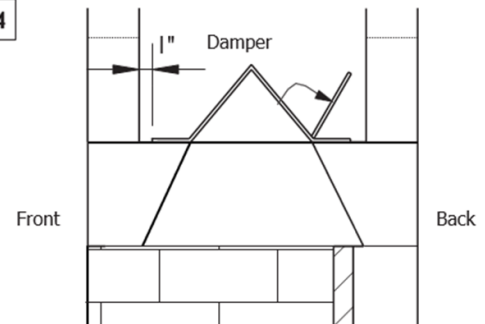
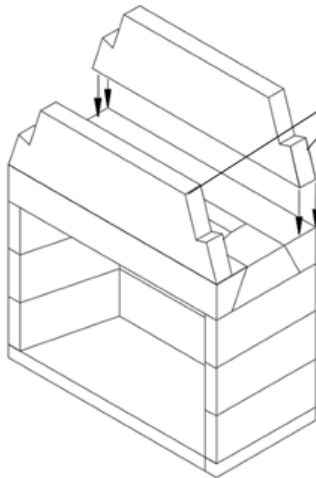


FIGURE 24



Assembly Instructions - STANDARD Series 36, 42, & 46

FIGURE 25



SMOKE DOME:	
80S36	PART #11
80S42	PART #11
80S46	PART #13

8. Set the rear smoke dome component across the damper beam in a bed of Earthcore Adhesive and flush with the back face of the back-damper beam lintel.

Set the front smoke dome component in Earthcore Adhesive across the front damper beam. The smoke dome component should be flush with the front of the front damper beam. (Figure 25).

NOTE: On the **80S42**, the smoke dome will not go all the way to the sides of the firebox. There will be 3" on both sides of the smoke dome top. Please see page 10 for reference.

9. Position the smoke dome's sloping side walls at each end of the smoke dome components.

The sloping side walls fit in between the front and rear smoke dome components and fit into the haunches at the ends of the front and rear smoke dome components. Earthcore Adhesive all contact surfaces thoroughly. The smoke dome sloping side walls have a beveled bottom edge so that they will sit tight onto the flat top of the damper beam assembly (Figure 26).

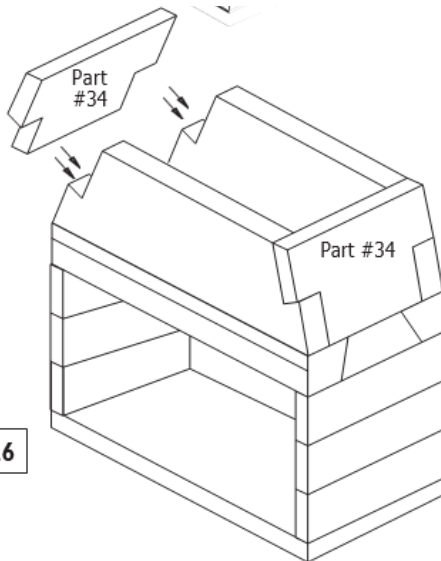
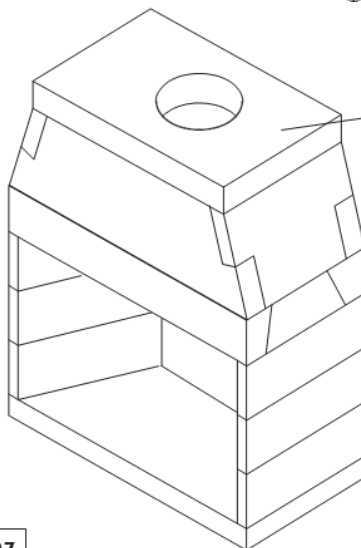


FIGURE 26

10. Apply Earthcore adhesive to the top of the smoke dome wall assembly and set the top plate into position.

One side of the top plate shows a thickened center. This side is the bottom face.

The flue hole in the top plate is centered in the smoke dome from side to side but is offset from front to back, the center being ten and three-fourths inches (10-3/4") from the back of the firebox (Figure 27).



SMOKE DOME:	
80S36	PART #M77
80S42	PART #M77
80S46	PART #M81

FIGURE 27

DM Chimney Components & General Information

The DM chimney is a dual module, refractory masonry chimney system. It is composed of two precast mating components; the outer casing liner, and an inner liner.

This chimney system is designed for installation in accordance with the National Fire Protection Standard for Chimneys and Solid Fuel-Burning Appliances, NFPA 211 and in accordance with codes, such as ICC, BOCA Basic/National Codes, the standard Mechanical Code, and the Uniform Building Codes.

Required DM Chimney Clearance

The DM chimney system, rated UL 103HT, is listed for zero clearance to normal construction materials. The DM chimney system may be enclosed in a wood chimney chase at zero clearance to wood framing members.

Since lateral support is required for DM chimneys the framing members will be in contact with the DM chimney system.

IMPORTANT: “Combustibles” are defined as “normal construction materials” and are considered to be framing materials, particle board, mill board, drywall, plywood paneling, plywood sub flooring, and wood flooring.

Keep all insulation, vapor barriers, “house wrap” paper and other insulating type membranes and products, including fiberglass, cellulose, and other insulation (anything that carries an “R” rating) a minimum of three inches (3”) away from all firebox and chimney surfaces.

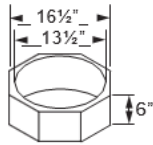
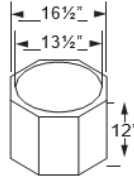
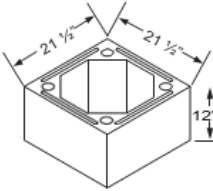
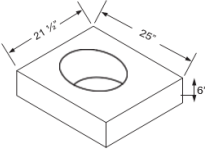
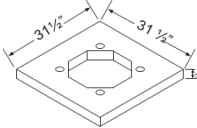
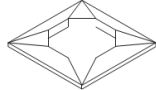
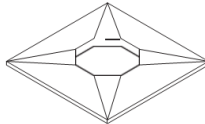



EXCEPTION: If insulation is used in walls surrounding the fireplace, insulation may be installed behind sheathing of gypsum board, plywood, particle board, or other material on the side facing the Isokern. The facing material cannot be within 1-½” to the fireplace side walls.

Mechanical Vent Systems

It is acceptable to use mechanical draft systems, if the venting companies do the engineering calculations and make the necessary recommendations for fan size and flue vent diameter following the guidelines of NFPA 211, page 211-13. Installation of such systems must also follow the mechanical drafting company’s explicit installation and operation instructions.

Isokern DM Chimney Weights

Total installed chimney weight will vary and be based on the overall height and the configuration of the chimney system. Chimneys may be straight vertical stacks of DM outer casing and inner liner (**see page 3**) but may also include the use of offset chimney blocks, brick ledge, chimney reinforcement, brick/stone veneers, cement crown caps and clay chimney pot termination with additional structural support.

Component	Part#	Description
	70003	Isokern DM Chimney 6” Starter Inner Liner
	70235	Isokern DM Chimney 12” Inner Liner
	45433	Isokern DM Chimney 12” Outer Casing
	40136	Isokern DM Chimney Offset Block
	40111	Isokern Brick Ledge
	40322	Isokern Small Crown Cap
	40323	Isokern Large Crown Cap
	50001	ISO-Cap Spark Arrestor - Stainless Steel
	50003	ISO-Cap Spark Arrestor w/ Damper - Stainless Steel (Shown) Fits Inner Liner
	50004	ISO-Cap Spark Arrestor - Black Galvanized Fits Outer Liner
	50006	ISO-Cap Spark Arrestor - Copper Fits Inner Liner

Chimney Height Requirements

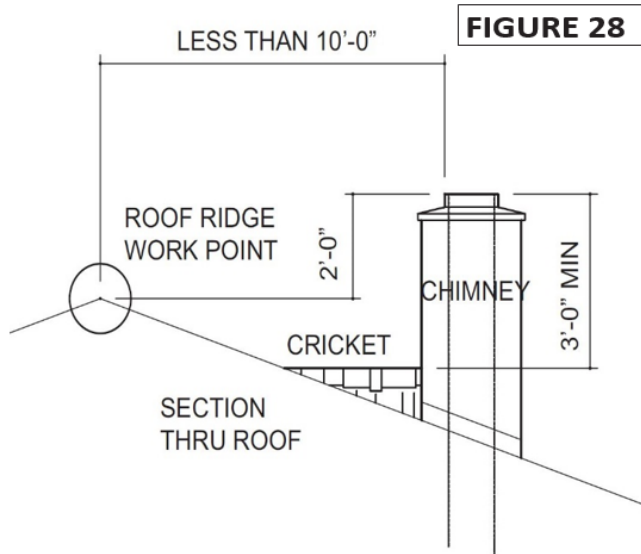


FIGURE 28

The DM chimney component weights are as follows:

Part	Weight
Small crown cap:	80 lb.
Large crown cap:	100 lb.
Brick ledge:	110 lb.
6" Inner Liner:	19 lb.
12" Inner Liner:	45 lb.
Outer Casing:	90 lb.
Offset block*:	110 lb.

*Construction of an offset block sequence will shift a portion, if not all, the chimney load off of the firebox and smoke dome. Additional reinforced concrete footing and slab area may need to be provided adjacent to or as a continuation of the primary support slab area for bearing the steel or masonry support required for an offset sequence. (See pages 30-32) Consult a structural engineer for specific, individual structural requirements.

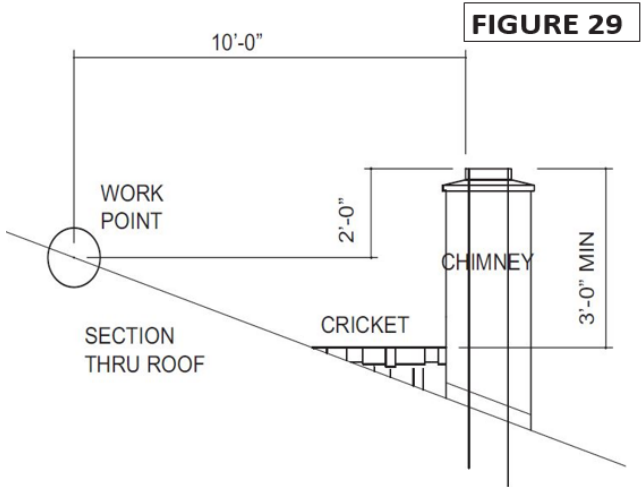


FIGURE 29

The required minimum chimney height above the roof and adjacent walls and buildings is specified by all major building codes and is summed up in what is known as "the 2-foot in 10-foot rule:"

If the horizontal distance from the roof ridge to the opening of the chimney is less than 10', the top of the chimney must be at least 2' above the roof ridge.

If the horizontal distance from the opening of the chimney to the roof ridge is more than 10' then a chimney height "work point" is established on the roof surface 10' horizontally from the opening of the chimney. The top of the chimney must be at least 2' above this work point.

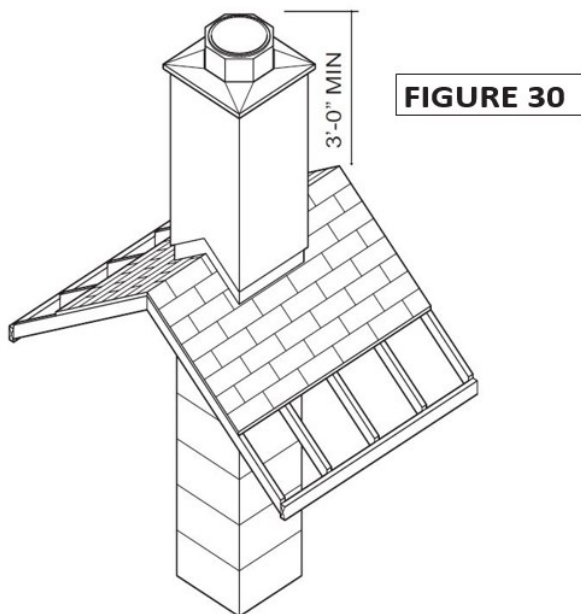


FIGURE 30

In all cases, the chimney cannot be less than 3' above the roof at the edge of the chimney (Figures 28 & 29).

A simple example of this would be if the roof is flat, then the chimney would need to be at least 3' above the roof surface. Or, if the chimney penetrates the roof at the ridge, then the chimney must be at least 3' above the ridge (Figure 30).

NOTE: The "2 foot in 10-foot rule" is necessary in the interest of fire safety but does not ensure smoke-free operation of the fireplace. Trees, buildings, adjoining roof lines, adverse wind conditions, etc. may require a taller chimney for the fireplace to draft properly.

As with all chimney installations, avoid overhead obstructions such as trees, power lines, etc.

DM Chimney Installation - Straight Run

Where the chimney run is to be straight run, start the DM chimney by setting a DM outer casing in a bed of Earthcore Adhesive on top of the STANDARD top plate. The outer casing is to be centered from side-to-side and flush with the back of the top plate. Be sure that the outer casing aligns with the flue hole in the top plate. The DM outer casing will sit three and three-fourths inches (3-3/4") back from the front face of the top plate.

This total set-back distance makes it possible for a three and one-half inch (3-1/2") thick bearing header to pass over the STANDARD firebox smoke dome assembly and for the DM chimney to run straight up the back side of the bearing header (**Figure 31**).

Next, set the DM inner liner's six-inch (6") tall "starter" piece inside the first outer casing. The six-inch (6") tall inner liner has a female end and a flat end. Set this inner liner with the flat end down. Be sure that the starter piece is set into the Earthcore Adhesive so it is fully sealed to the top plate.

IMPORTANT: Earthcore Adhesive all outer casings together, and Earthcore Adhesive all inner liners together. **DO NOT Earthcore Adhesive the air space between the liners and the outer casing blocks.**

For every 12' of DM54 Flue, you should order a bucket of Earthcore Adhesive MP50.

Starting with the six-inch (6") tall inner liner starter piece creates six-inch (6") staggered horizontal joints between the inner liner and the outer casing as the chimney is built up.

Both the outer casing and the inner liner components have tongue and groove type detailing on each end to assure alignment and interlock of the pieces as they are stacked and glued together.

NOTE: If the six-inch (6") inner liner starter piece is broken or otherwise unavailable, then a full twelve-inch (12") tall inner liner piece can be cut to six inches (6") in height to make an inner liner starter piece.

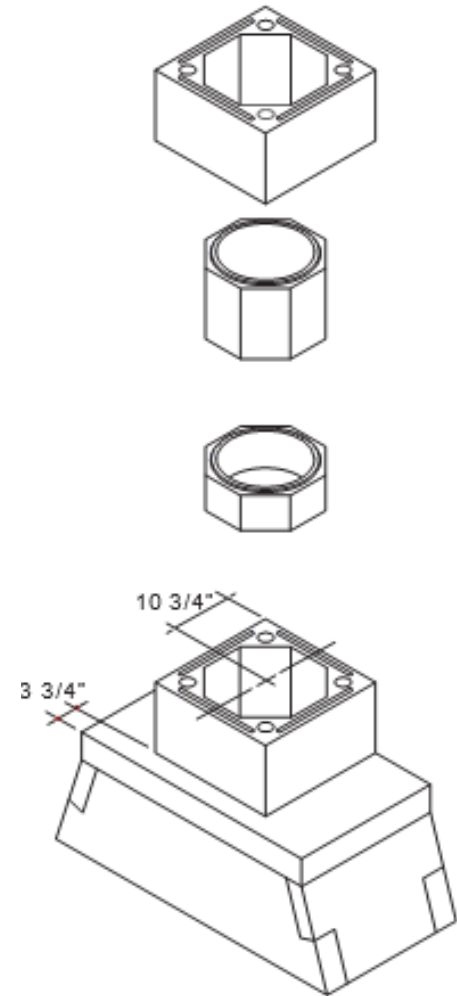
After setting the DM inner liner starter piece, apply Earthcore adhesive to the top of the starter liner. Continue the straight chimney run by placing a full height inner liner onto the six inch (6") starter liner. The top of this full height inner liner will sit 6" above the top of the outer casing block that was previously set.

This six inch (6") offset between joints of the inner liner stack and the joints of the outer casing stack continues to the top of the chimney run. (**Figure 43**)

Continue the straight vertical DM chimney by setting an outer casing onto a bed of Earthcore adhesive on the top surface of the preceding outer casing. The grooves on the bottom end of the upper outer casing fit onto the tongues on the top of the lower outer casing block. This assures proper alignment of the two components.

Next place a full height inner liner onto a bed of Earthcore adhesive on the top end of the previously set inner liner. Proceed this alternate stacking of outer casing and inner liners until the desired height of the flue is attained.

FIGURE 31



DM Chimney Installation - Straight Run

FIGURE 32

Lateral Support for DM Chimneys

Though not required, it is recommended that where the DM chimney is built up along an exterior wall the vertical chimney system can be connected to the structural wall system at a minimum of four-foot (4') intervals. This connection can be made using 18-gauge strap ties (Simpson Strong Tie CS coil strap, or equivalent).

Starting on one side of the DM chimney, at four-foot (4') intervals up the structural wall adjoining the chimney, connect one 18-gauge strap tie to the structural wall with two, three-inch (3") #8 (minimum) wood screws or masonry anchors, as appropriate.

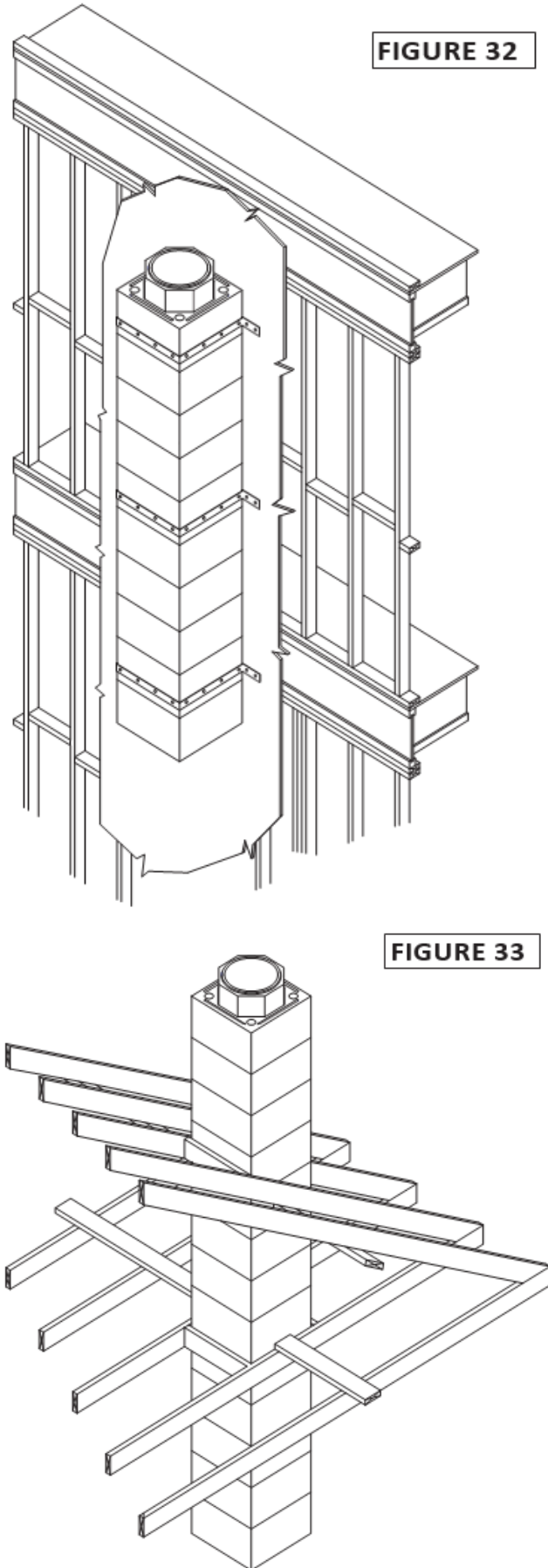
Next, fold the strap around the three exposed sides of the outer casing. Connect the strap to each of the three outer casing faces with two (2) one and one-half inch (1-1/2") long masonry anchors, such as "Tapcon" or "Titen" screws. Fasten the strap back to the structural wall with two (2) three-inch (3") #8 (minimum) wood screws or masonry screws, as appropriate (Figure 32).

Where DM chimney is built up from the interior walls the DM chimney outer casing block is to be laterally braced at ceiling and roof penetrations.

Pressure treated 2" x 4" blocks, set at each side of the flue between the trusses or rafters and fastened to the pre-engineered roof trusses or rafters with two 16d common nails at each end, provides lateral support, parallel with the framing.

Additionally, a two inch (2") by four inch (4") by six feet (6') minimum pressure treated member ("rat run") installed on each side of and butted up to the outer casing block will provide lateral support perpendicular to the direction of the truss or rafter framing system.

Fasten the perpendicular member with two 16d common nails to each intersecting truss or rafter. The perpendicular bracing should be installed on the top side the ceiling level framing as well as on the bottom side of the rafters (Figure 33).

FIGURE 33


DM Chimney Installation - Offset Run

DM Offset Block

The Isokern Offset Chimney Block is used for DM Chimney to bypass overhead obstructions. Offset blocks are six inch (6") thick, single module chimney components, measuring twenty-one and one-half (21-½") wide by twenty-five (25") long. The fourteen-inch (14") hole passes through the block at thirty (30°) degrees. An offset block can be set as the first flue component on top of the STANDARD top plate.

Offset chimney block sequences can be built to shift the chimney run to the left, right, or to the rear of the firebox/ smoke dome assembly.

Offset blocks can be set in a spiraling rotation, thus moving the chimney to a point that is diagonally away from its starting point.

Offset blocks require 1-½" to combustible framing.

DM Chimney Offset Block Installation and Support Foundations

Isokern offset chimney blocks are stacked in a stair step fashion with each successive block overhanging the previous offset block by three inches (3"), allowing the flue to rise at an angle of thirty (30°) degrees off vertical (**Figure 34**).

Each offset block is to be set fully in a bed of Earthcore Adhesive, completely sealing each offset block to the underlying component. When placing the first inner liner on top of the last offset required, seal the space between the inner liner and the offset block with Earthcore Adhesive so that no smoke will be able to spill through the two joints.

When building offset sequences, it is necessary to support the third offset block in the sequence and every third offset block thereafter to footings via concrete block or steel support columns. When using only one or two offset blocks no additional support is required. Always support the last offset block in a sequence for full support of the DM chimney where it returns to vertical.

During this building process, it is important to check the interior flue alignment as each offset block is set to avoid creating overhanging ledges on the inside of the flue. Such internal overhangs will inhibit flue drafting.

If a DM Offset sequence cannot be done at the beginning of the chimney sequence, you must consult a structural engineer to ensure proper support is in place for the DM Chimney Offset.

Plan fireplace and DM chimney systems carefully before foundations are laid to assure that proper footings are available to support Isokern offset blocks and chimney run.

To calculate the distance of Isokern offset chimney travel in a straight line to the right, left or to the rear of the firebox/ smoke dome assembly, proceed as follows:

Temporarily dry set a DM outer casing block in its proper location on top of the completed firebox/smoke dome assembly as though starting a straight chimney (**Figure 35**).

FIGURE 34

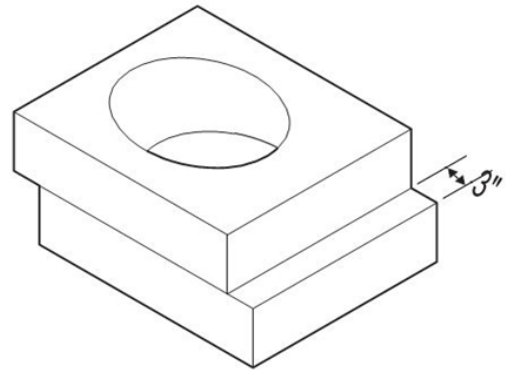
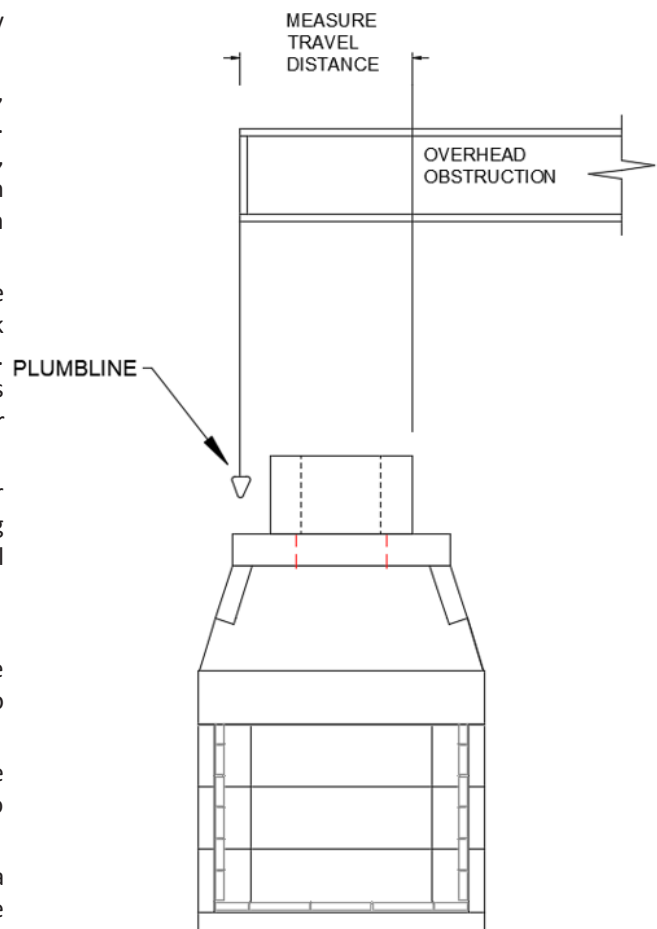
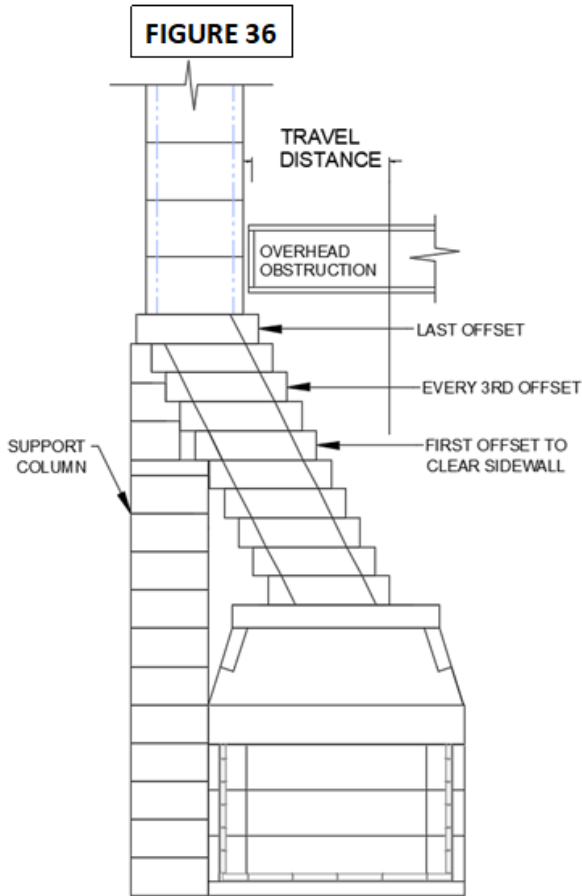


FIGURE 35



DM Chimney Installation - Offset Run

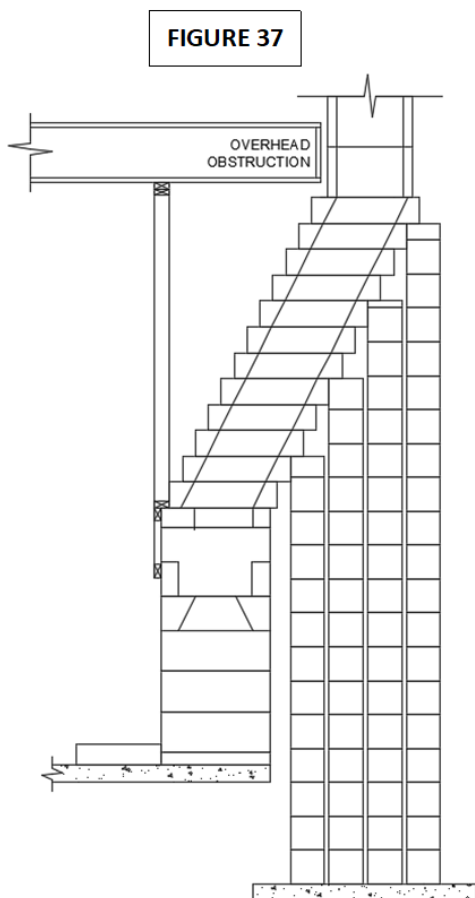


If the offset sequence is to move to the left, then, starting from the right-side of the temporary DM outer casing measure leftward to the far face of the overhead obstruction that needs to be bypassed by the vertical chimney run.

For accurate measuring, drop a plumb line down from the far face of overhead obstruction to the level of the top of the smoke dome assembly. Measure from the far side of the temporary DM outer casing to the plumb line. This measurement, taken in inches and divided by three (three inches of horizontal travel per offset block) gives the total number of offset blocks needed to accomplish the required travel distance (**Figure 35**).

To calculate the height that the offset block sequence will require, take the total number of offset blocks needed to accomplish the travel distance (described above) multiplied by 6". This number is the height (inches) that the offset sequence will require.

When establishing the "far face" of the overhead obstruction, be sure that the DM chimney blocks can run straight to chimney termination without further overhead obstruction since a second offset sequence is not allowed (**Figures 36 & 37**).



Be sure that there is sufficient space beyond the "far face" of the overhead obstruction to accept the DM chimney's outer casing dimension of 21-1/2".

IMPORTANT: Always support the last offset block in a sequence for full support of the DM chimney where it returns to vertical.

Support columns often carry most of the total load of the vertical chimney that is set onto the last offset block.

The total chimney weight above the last offset block will be the total weight of the vertical chimney plus any additional allowable loads, such as the Isokern brick ledge, its related brick or stone veneers, and any crown caps, clay pots, or other masonry chimney terminations.

Be sure the foundation under all support columns is made of concrete or steel and designed to support the loads applied to it. Do not make support columns of brick, stone, or wood. All support columns must bear onto proper non-combustible foundations.

DM Chimney Installation - Offset Run & Brick Ledge

Offsets to the Left or Right:

When offsetting chimneys to the left or right of the firebox, it is not possible to build a support column directly under the third offset block.

To create proper support, construct a support column against the side of the firebox up to the level of the top of the top plate. Span the distance from the column with two pieces of four-inch (4") by four-inch (4") by five-eighths inch (5/8") steel angle to the edge of the first offset block. **(Figure 38).**

For 80S36 and 80S42 Models Only: To ensure the steel has adequate bearing distance on the top plate, the first offset block in each sequence will require two 6" x 3-1/2" x 5/8" deep notches to be cut into its underside to accept these angles **(Figure 38, Detail A)**

For 80S36 and 80S42 Models Only: Ensure that the notches are cut accurately and do not encroach to within 2" of opening on the bottom face of the offset block.

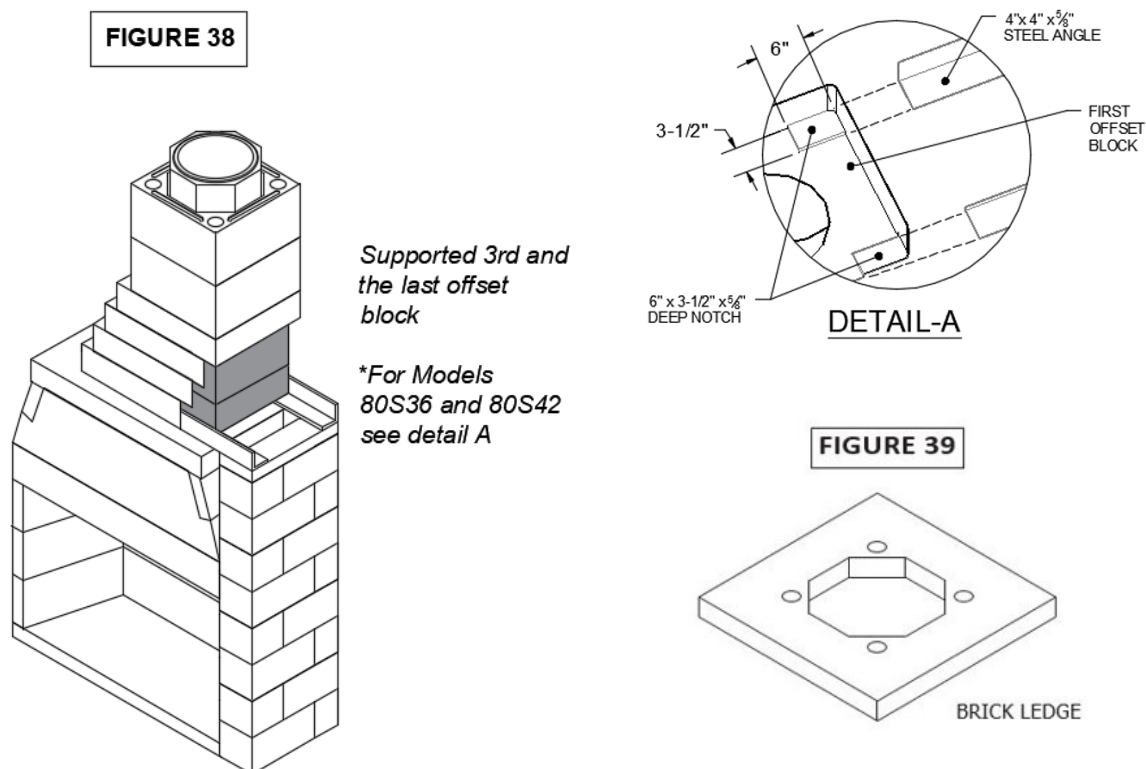
For 80S36 and 80S42 Models Only: Once the offset has been notched and the angle irons set in position, the offset block are set fully in a bed of Earthcore Adhesive. Be sure to completely seal the offset block to the top plate. Ensure the angle irons are set into the notches, are parallel and flush to the sides of the offset block, and bear fully on the concrete or steel support column.

On the steel angles, build a masonry or steel support column up to the underside of the third offset block in the sequence. Ensure that the third offset, as well as the last offset in any sequence are supported. **(Figure 38).**

NOTE: For offset chimney block sequences that clear the side wall of the firebox below, it is allowable to support the first offset block that clears the firebox side wall and then to proceed with supports at each third offset block thereafter **(Figure 36).**

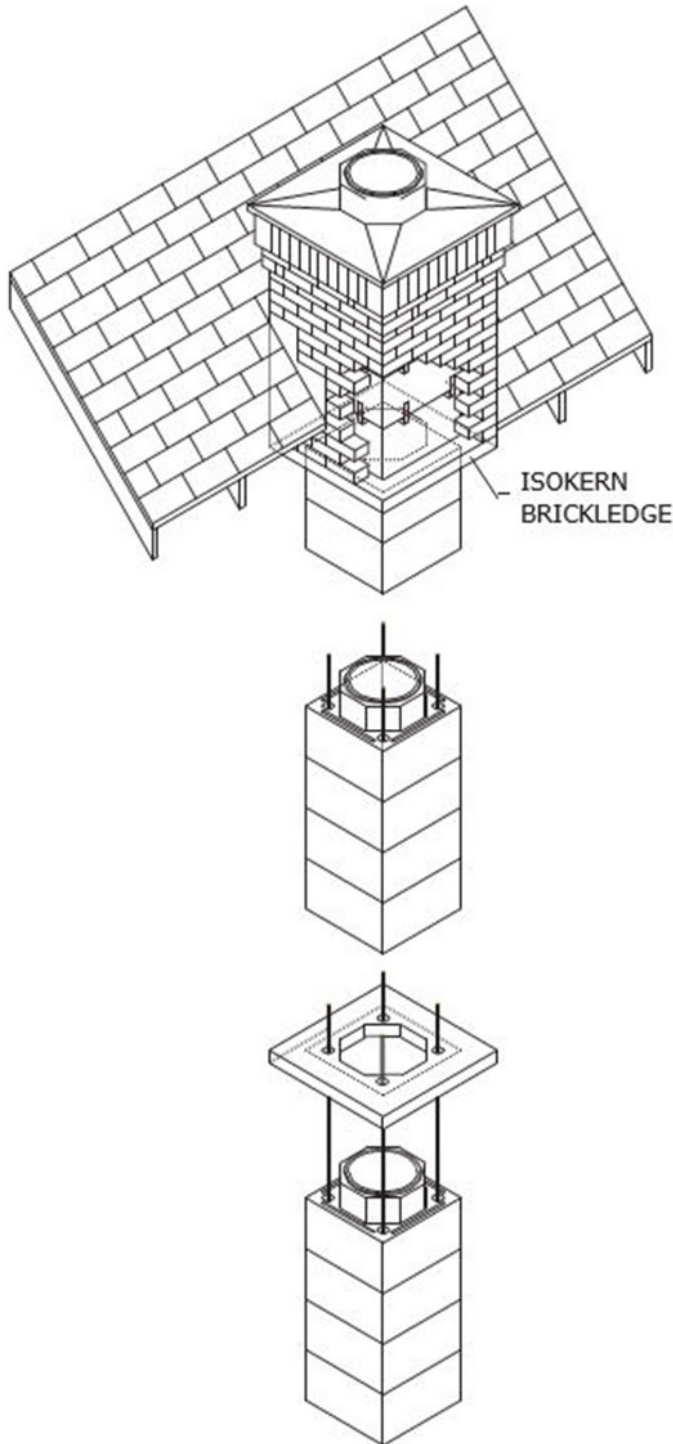
DM Brick Ledge

The DM brick ledge is a 31-1/2" x 31-1/2" x 3" thick, steel reinforced, concrete and pumice slab. It provides a 5" ledge at all four sides of the outer casing block and is designed to support masonry veneers to DM chimneys starting below the rafters and continuing to termination **(Figures 39, 40, & 41).**



DM Chimney Installation - Brick Ledge

FIGURE 40



The component is cast with an octagonal hole in its center so that the DM octagonal inner liner can pass through it. The brick ledge has four 2-½" holes through it that align with the hole in each of the four corners of the DM outer casing block. These four holes are provided for reinforcement of the chimney stack by the insertion of #4 (minimum) steel reinforcing rods and subsequent grouting (**Figures 40, 41, & 42**).

The brick ledge is only intended for use in chimneys that rise through the roof only where all four sides of the chimney are bounded by the roof.

IMPORTANT: To maintain structural performance, the DM brick ledge must not be cut or altered in any way.

DM Brick Ledge Installation

Use of the brick ledge will require a rough opening in the roof framing of at least 34" in width. The required opening dimension along the length of the rafter, where the chimney is to penetrate the roof line, will increase above 34" relative to the pitch of the roof.

As the DM outer casing and inner liner assembly approaches the roof penetration set an outer casing block to a level of approximately 6" below the low side of the roof framing (**Figure 40 and 41**).

The alignment tongues on the top of this outer casing block must be ground off to leave a flat contact surface for the brick ledge. Temporarily leave out the inner liner that fits this outer casing block.

Set the Isokern brick ledge onto the flat top surface of the outer casing in a full bed of Earthcore Adhesive. Be sure to align the four 2-½" holes in the brick ledge with the matching holes in the outer casing block below it. Return to setting the next inner liner in the sequence. This inner liner comes up from below and passes through the octagonal hole in the brick ledge. The liner's top end will be approximately 3" above the top surface of the brick ledge. Set the next outer casing block onto the top of the brick ledge in a bed of Earthcore Adhesive.

Insert one piece of #4 (minimum) steel reinforcing rod into each of the four 2-½" holes in the brick ledge. The reinforcement rods must start from a depth of at least 18" below the bottom of the brick ledge. (In some cases, a minimum recommendation could be 5')

If short lengths of steel rods are used, be sure to properly lap and wire tie all splices in the rebar. As the reinforcing progresses, completely fill the holes with grout. Suitable grout can be a pourable mixture of Portland cement and sand or Portland cement, sand, and pea gravel. The rebar must be fully embedded in grout.

Leave enough of the #4 steel reinforcing rod exposed above the brick ledge so that as the stacking of outer casing blocks continues to termination the reinforcing rods and grout can continue through the stack. Reinforcing shall continue to chimney termination.

All DM chimneys that include the DM brick ledge must be reinforced as described above.

DM Brick Ledge

CAUTION: When using the Isokern brick ledge, it is required that the STANDARD firebox/smoke dome assembly include the placement of a 4" x 4" x 3/8" minimum steel angle across the firebox opening

Lateral Support for Isokern Brick Ledge Chimneys

Once the DM chimney and brick ledge are assembled and after the intended masonry veneer has been installed on the brick ledge, be sure to brace the chimney following the guidelines of this manual for Lateral Support of DM chimneys.

Load Capacity for DM Brick Ledge

The sources of load delivered into the Isokern brick ledge are: (1) the total physical load of brick, stone, or other masonry veneer on the brick ledge, and (2) loading due to the force of wind delivered against the exposed height of the chimney mass.

The required height of any chimney is governed by applicable local building codes. The overall finished height of any chimney varies based upon site-specific conditions (e.g., elevation of roof line, roof pitch, distance of the chimney from the ridge, etc.).

It is relatively simple to calculate the total physical load on the brick ledge resulting from the physical weight of applied veneers built to code height. However, calculation values for load to the brick ledge due to wind are site specific and based on local variables such as wind speed zone, exposure classification, eave height and roof pitch of the structure, as well as height of chimney mass exposed to wind.

IMPORTANT: The total load delivered into the brick ledge is job specific and will be the sum of:

- 1.the physical load from veneers, plus
- 2.the load due to wind.

The total physical load and load due to wind must not exceed ninety-four hundred (9,400) pounds.

IMPORTANT: Do not subject the brick ledge to unequal loading when applying veneers. Build veneers equally on all four sides of the brick ledge.

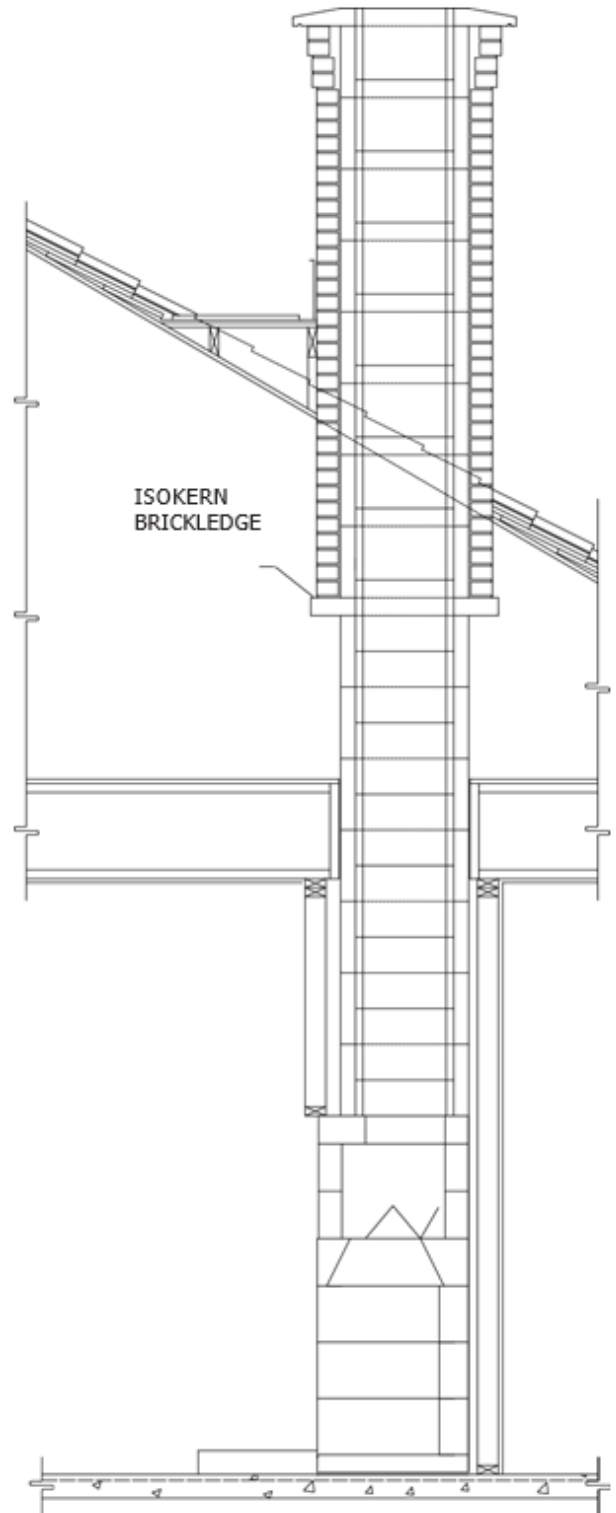
Brick Ledge Veneer Finish and Flashing Details

When applying brick, stone, or other masonry veneer to the Isokern brick ledge, standard good building practices for masonry veneer work should govern weather-proofing details and the placement of flashings.

A typical flashing detail would be to field fabricate an aluminum or galvanized sheet metal flashing, approximately 32" square with a 20" square hole in it, to serve as an inner flashing.

Place the inner flashing on the first DM outer casing block that fully clears the roof line. Keep the flashing to about a half-inch (1/2") lap onto the top of the outer casing block. The twenty-inch (20") square hole in the flashing should fit to the outside of the alignment grooves on top of the DM outer casing. Continue the DM chimney up to the required termination height.

FIGURE 41



DM Brick Ledge & Crown Caps

Once the masonry veneer is in progress, the inner flashing is set into a horizontal joint in the veneer at a level above all other roof deck flashings, chimney-to-roof flashings, and counter flashings. Weep holes should open to the outer face of the veneer at vertical mortar joints located at the level of the inner flashing (**Figure 42**).

Where moisture may develop between the DM outer casing and the chimney veneer, inner flashings as described above will help to divert such moisture to exterior face of the veneer by way of the weep holes and thereby keep such moisture from working its way down between the veneer facing and the DM outer casing and into the interior of the structure below.

DM Large Crown Cap

The DM large crown cap is a prefabricated cement weather cap for masonry veneer chimneys. The large crown cap measures 37-1/2" square and is 3" thick at its center. (**Figure 43**)

The component has an octagonal hole at its center so that the top inner liner of the DM chimney stack can pass through it. The crown cap then sits on the topmost DM outer casing block.

To set the large crown cap the last inner liner should be at least 3" above the last outer casing block in the chimney stack.

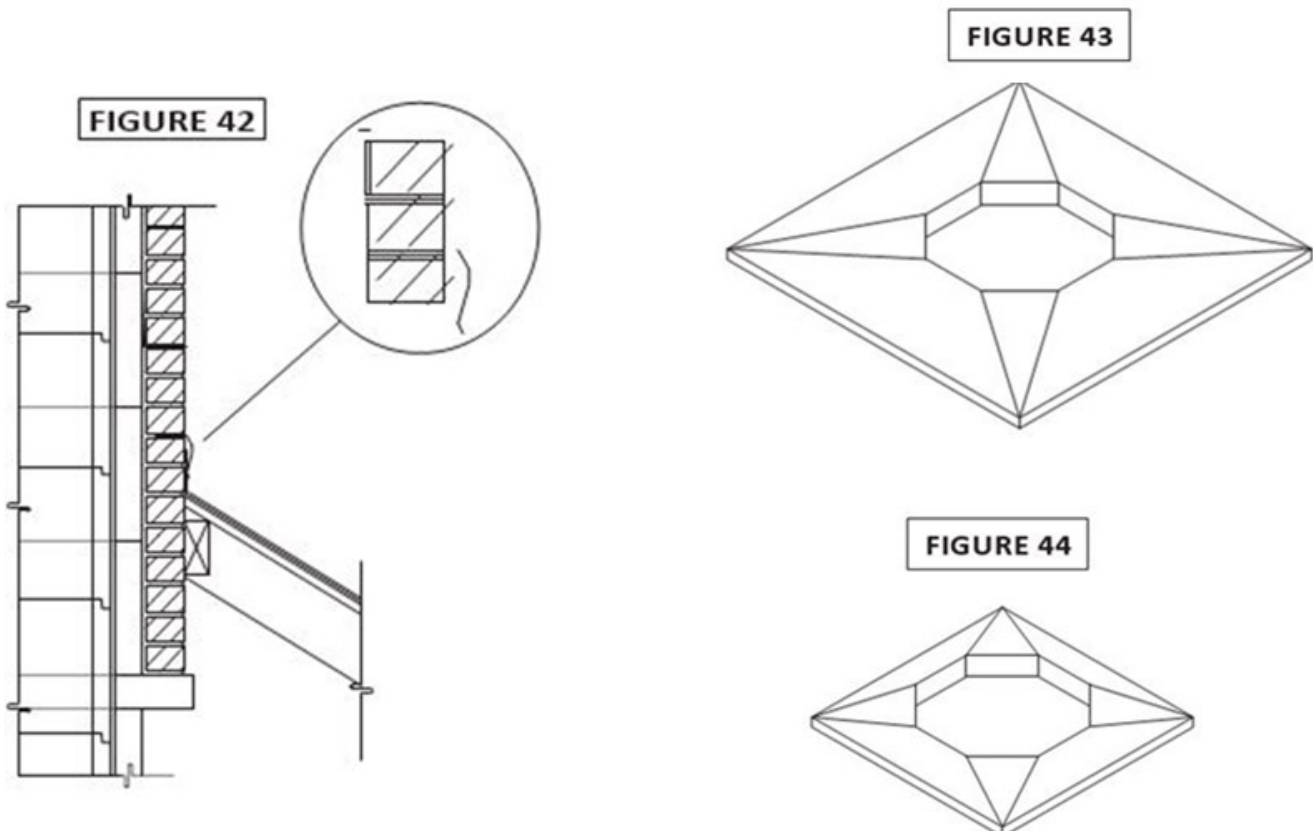
Mortar the top of the last outer casing block. Set the large crown cap over the inner liner and onto the top of the last outer casing in the stack.

Caulk or mortar the joint between the octagonal liner and the crown cap where the liner comes through the top surface of the large crown cap.

DM Small Crown Cap

The DM small crown cap is a prefabricated cement weather cap that measures 26- 1/2" square and 3" thick. The small crown cap is designed and installed the same as the large crown cap. (**Figure 44**)

The small crown cap is intended for use where DM chimneys are to receive thin veneers and cultured stone that do not require the installation of the Isokern brick ledge. The small crown cap is also suitable where DM chimneys are to receive a stucco finish. Other chimney terminations are possible with DM chimneys. Check local codes for use of custom chimney terminations and decorative shrouds.



DM 54 Chimney Terminations

ISO-Cap

The ISO-Cap is a Spark Arrestor/Rain Cap designed to fit atop the Isokern DM 54 Chimney Inner Liner and is available in Stainless Steel, Black Galvanized, Copper, or a Stainless Steel with Damper (Figure 45).

A 14"-diameter sleeve projects from the bottom of the ISO-Cap and inserts into the DM 54 Inner Liner. A two-inch (2") wide flange at the base of the ISO-Cap covers the top surface of the DM 54 Inner Liner to protect the liner from weather.

To Install the ISO-Cap, silicone caulk is used to adhere the two-inch (2") flange to the top of the DM 54 Inner Liner.

Decorative Clay Pots

The Elemental Clay Pots are set in a bed of Earthcore Adhesive on the DM 54 Chimney Inner Liner. The base of the chimney top does not need to match the dimensions of the inner liner it is being installed on top of but should not impinge on the inside area of the flue liner except for the maximum of 3/4" in the corners. The flue liner may extend up inside the chimney top, or the flue liner may be flush with the top surface of the chimney cap. Additional anchoring may be used to prevent damage from tornadoes, hurricanes, or earthquakes. A 1/4" to 1/2" diameter hole may be drilled in at least two opposite sides of the chimney top and a bar used to anchor the top into the grout or the chimney walls (Figure 46).

NOTE: The Elemental Clay Pots can only be installed on the DM 54 Chimney System. The Clay Pots are not tested and listed for use with Metal Chimney Flue Systems.

Custom Chimney Caps

A non-combustible, weather tight chase flashing must be used to cover the top of the chimney chase. Be sure to seal the joint where the DM liner passes through the chase top flashing for positive weather seal. Chase flashings may be supplied by others. (Figure 47)

Special design caps may be designed and constructed by others and must be fashioned so as not to restrict the flow of smoke and gases out the top of the flue opening. The figure below depicts common chimney terminations.

Check with local building codes to establish the need for chimney caps and spark arrestors or for any limitations to their design and use.

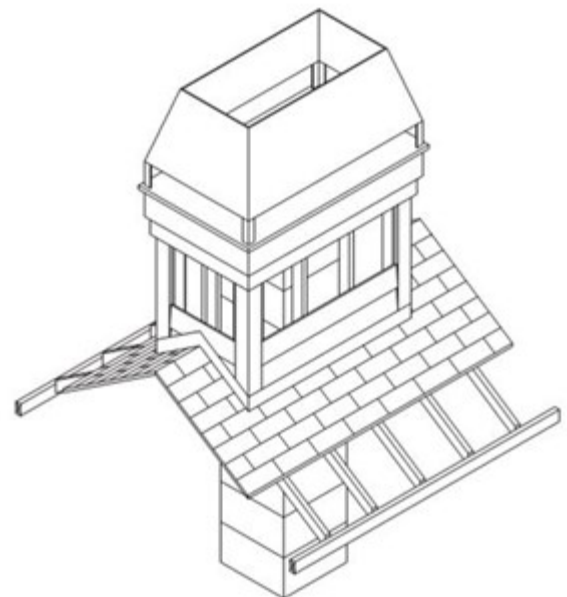
FIGURE 45



FIGURE 46

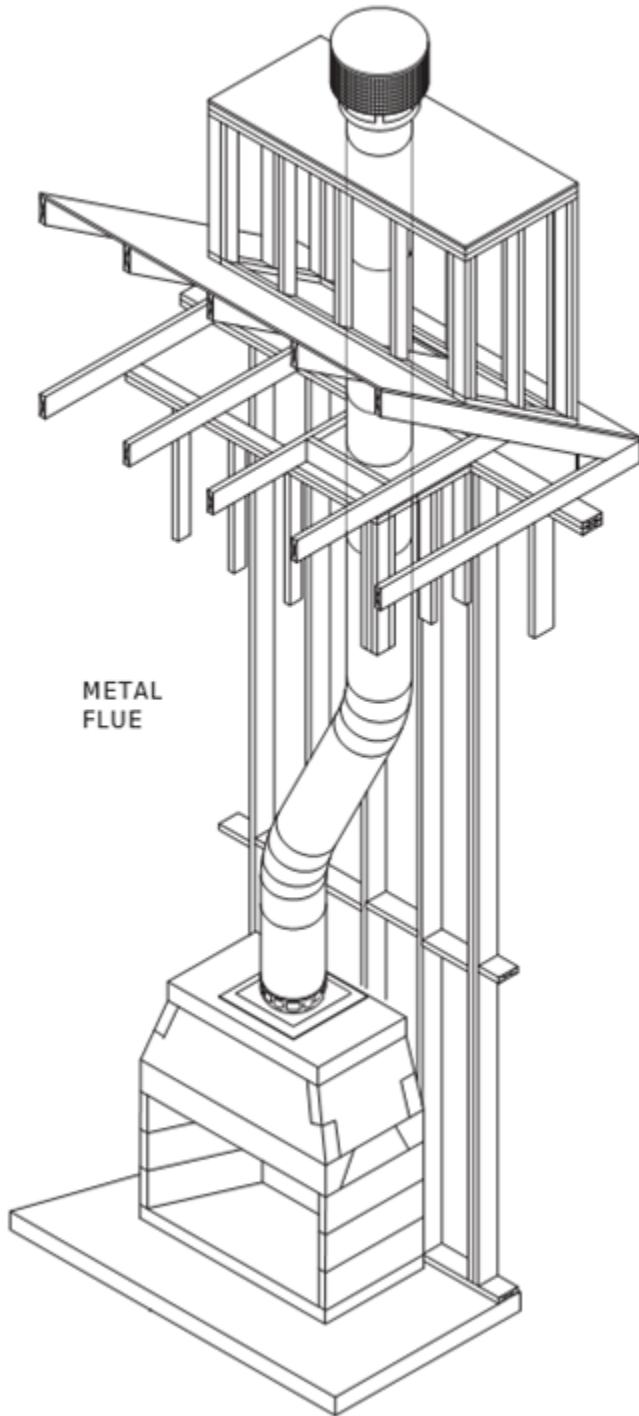


FIGURE 47



ECO-STEEL & ECO-STEEL+ Metal Chimney Flue

FIGURE 48



The STANDARD Series Fireplaces are tested and listed for use only with Earthcore's Proprietary ECO-STEEL & ECO-STEEL+ chimney systems complying with UL103/ULC-S604 Standard.

Metal Chimney Types:

ECO-STEEL

A lightweight venting solution created so each section connects securely together. This versatile system has a 12-5/8" inner diameter and 15-5/8" outer diameter and is available in two options. Eco Steel Class-A Insulated has stainless-steel outer and inner pipe:

Air Cooled Chimney Features

- Double wall, non-insulated
- Locking-tab design

Insulated Chimney Features

- Double wall with solid-pack insulation
- Locking-tab design

ECO-STEEL+

A lightweight venting solution created so each section connects securely together. This versatile system has a 13" inner diameter and 16" outer diameter and is available in two options. Eco Steel Plus Insulated has stainless-steel inner and galvalume outer pipe:

Air Cooled Chimney Features









- Double wall, non-insulated
- Twist lock design


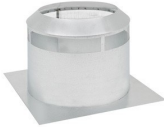







Insulated Chimney Features

- Double wall with solid-pack insulation
- Screw assembly








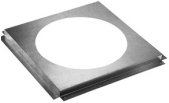

NOTE: ECO-STEEL & ECO-STEEL+ are not designed for use on products that operate at continuous temperatures in excess of 1000 °F, intermittent temperatures of 1700 °F are acceptable. Only use approved terminations and chimney shrouds provided by Earthcore. Be sure to maintain a 2" clearance to combustibles around the metal chimney flue.

Components List - ECO-STEEL Air Cooled & Insulated Metal Chimney Flue

AIR-COOLED		
Component	Part#	Description
	13ACECO6	6" Chimney Section
	13ACECO12	12" Chimney Section
	13ACECO18	18" Chimney Section
	13ACECO36	36" Chimney Section
	13ACECO48	48" Chimney Section
	13ACECOAP	Anchor Plate
	13ACECOAPD	Anchor Plate w/Damper
	13ACECO15OS	15 Degree Offset
	13ACECO30OS	30 Degree Offset
	13ACECOFC	Chase Top Flashing
	13ACECOSC	Storm Collar
	13ACECOFS	Firestop

INSULATED		
Component	Part#	Description
	13ACECOFT	Tall Cone Flashing 1-6/12 and 7-12/12 roof flashing
	13ACECOIS	Attic Insulation Shield
	13ACECOWB	Wall Band
	13ACECOCC	Chimney Cap - Stainless Steel
	13INECO6	6" Insulated Chimney Section Stainless Steel
	13INECO12	12" Insulated Chimney Section Stainless Steel
	13INECO18	18" Insulated Chimney Section Stainless Steel
	13INECO36	36" Insulated Chimney Section Stainless Steel
	13INECO48	48" Insulated Chimney Section Stainless Steel
	13NECOAP	Insulated Anchor Plate Stainless Steel
	13INECOAP	Insulated Anchor Plate w/ Damper Stainless Steel
	13INECO15OS	Insulated 15 Degree Offset Stainless Steel
	13INECO30OS	Insulated 30 Degree Offset Stainless Steel

Components List - ECO-STEEL+ Air Cooled Metal Chimney Flue

Component	Part#	Description
	ECOP13AC-O6	6" Chimney Section
	ECOP13AC-12	12" Chimney Section
	ECOP13AC-18	18" Chimney Section
	ECOP13AC-36	36" Chimney Section
	ECOP13AC-KAP	Anchor Plate
	ECOP13AC-KAPD	Anchor Plate w/Damper
	ECOP13AC-E15	15 Degree Offset
	ECOP13AC-E30	30 Degree Offset
	ECOP13-CTF	Chase Top Flashing
	ECOP13-CTC	Storm Collar
	ECOP13-FS	Firestop
	ECOP13-FS30	30 Degree Firestop

Component	Part#	Description
	ECOP13AC-VC	Chimney Cap
	ECOP13-IS	Attic Insulation Shield
	ECOP13-WS ECOP13WS-SS	Wall Band
	ECOP13-CTC	Chase Top Collar
	ECOP13-SS	Supplementary Support
	ECOP13-ST	Stabilizer
	ECOP13-ST	Roof Radiation Shield (14"/16")

Components List - ECO-STEEL+ Insulated Metal Chimney Flue

Component	Part#	Description
	ECOP13IN-06	6" Insulated Chimney Section Stainless Steel
	ECOP13IN-06SS	6" Insulated Chimney Section Stainless Steel
	ECOP13IN-12	12" Insulated Chimney Section Stainless Steel
	ECOP13IN-12SS	12" Insulated Chimney Section Stainless Steel
	ECOP13IN-18	18" Insulated Chimney Section Stainless Steel
	ECOP13IN-18SS	18" Insulated Chimney Section Stainless Steel
	ECOP13IN-36	36" Insulated Chimney Section Stainless Steel
	ECOP13IN-36SS	36" Insulated Chimney Section Stainless Steel
	ECOP13IN-KAP	Insulated Anchor Plate
	ECOP13IN-KAPD	Insulated Anchor Plate w/ Damper
	ECOP13IN-E15K ECOP13IN-E15KSS	15 Degree Offset
	ECOP13IN-E30K ECOP13IN-E30KSS	30 Degree Offset
	ECOP13IN-VC	Insulated Chimney Cap
	ECOP13IN-ES	Elbow Strap

ECO-STEEL & ECO-STEEL+ General Information

The ECO-Steel Air-Cooled and Insulated Chimney is intended for use on Isokern fireplaces. Do not use with forced draft or positive-pressure appliances. The ECO-Steel Air-Cooled and Insulated chimney system is designed to extend a maximum of 60 feet vertically and with a maximum of two (2) offset (four elbows total) of up to 30° from vertical. Contact Local Building or Fire Officials about restrictions and installation inspection in your area. These instructions must be followed in all details and failure to do so may result in a hazardous installation.

The following instructions are a general representation for ECO-STEEL & ECO-STEEL+ Chimney Installation.

- ECO-STEEL Air-Cooled Chimney is not designed for use on products that operate at continuous temperatures of more than 1,000 °F.
- **Creosote and Soot – Formation and Need for Removal:** When wood is burned slowly, it produces tar and other organic vapors, which combine with expelled moisture to create creosote. The creosote vapors condense in the relatively cool chimney flue of the slow burning fire. As a result, creosote residue accumulates on the flue lining. When ignited, the creosote makes an extremely hot fire. The chimney should be inspected at least once every two (2) months during the heating season to determine if a creosote or soot buildup has occurred. If creosote or soot has accumulated, it should be removed to reduce the risk of chimney fire.
- Chimneys must be installed so that access is provided for inspection and cleaning.
- Never fill any required clearance space with insulation or any other building materials surrounding the chimney.
- Do not use a fireplace for food grilling. Grease from foods can collect in chimney causing fireplace to become a potential fire hazard.
- Some chemical chimney cleaners can be harmful to the chimney. These cause accelerated oxidation or corrosion. If chemical cleaners are used, they must be non-corrosive in nature. If a brush is used, it must be of proper size with plastic bristles. Have your chimney cleaned by a professional, certified chimney sweep.
- If a flue fire occurs, close all possible air inlets, and call your Fire Department. Do not use the chimney again until it has been inspected by a Certified Chimney Sweep for possible damage.
- Exterior metal parts, with exception of the top portion of the chimney cap, can be painted with a high temperature rust proof paint. Wash the metal surface with a vinegar and water solution to remove any residue before painting. Painting the chimney will help to increase chimney life.
- Earthcore assumes no liability for structural damage or roof contamination as the result of creosote formation. It is the owner's responsibility to comply with inspection and cleaning requirements as described in these instructions, and those of the appliance manufacturer.
- Interior chimneys shall be enclosed where they extend through closets, storage areas, occupied spaces, or anywhere the surface of the chimney could be contacted by persons or combustible materials. **The air space between the outer wall of the chimney and the enclosure shall not be less than 2 inches.**

WARNING: Do not place any type of insulation or other materials in the required clearance spaces surrounding the chimney assembly.

- Except for installation in one- or two-family dwellings, a factory-built chimney that extends through any zone above that on which the connected appliance is located is to be provided with an enclosure having a fire resistance rating equal to or greater than that of the floor or roof assemblies through which it passes.
- In cold climates, chimneys mounted on an outside wall should be enclosed in a chase. Exterior chases reduce condensation and creosote formation and enhance draft.
- Proper planning for your ECO-STEEL or ECO-STEEL+ Air-Cooled Chimney installation will result in greater safety, efficiency, and convenience. You must use only ECO-STEEL & ECO-STEEL+ Chimney parts and components to maintain a listed chimney system. Do not mix parts or try to match with other products or use improvised solutions.
- Install your Isokern fireplace as described in this installation manual and maintain all required clearances.
- Connect only one fireplace per chimney. Follow the fireplace safety manual for maximum efficiency and safety. Do not over-fire. Any damage to the fireplace or chimney can possibly void the warranty.
- Do not burn driftwood, plastic, or chemically-treated wood, such as railroad ties. They are corrosive to your chimney system.

NOTE: For ECO-STEEL installation, see pages 42-46. For ECO-STEEL+ installation, visit website earthcore.com to download pdf.

A MAJOR CAUSE OF CHIMNEY-RELATED FIRES IS FAILURE TO MAINTAIN REQUIRED CLEARANCE (AIR SPACES) TO COMBUSTIBLE MATERIAL*. MINIMUM CLEARANCE FOR 13" DIAMETER AIR-COOLED AND INSULATED CHIMNEY IS TWO (2) INCHES. IT IS OF UTMOST IMPORTANCE THAT THIS CHIMNEY IS INSTALLED ONLY IN ACCORDANCE WITH THESE INSTRUCTIONS.

ECO-STEEL Metal Chimney Installation

1. Mount Anchor Plate: Chimneys for Isokern fireplaces begin with an Anchor Plate or Anchor Plate with Damper.

It is important that the surface of the Isokern chimney has a level surface on which to attach the Anchor Plate. If the top of the Isokern does not have a level surface, then it will need to be modified accordingly.

Center the Iso-wool blanket over Isokern Top Plate hole and trace outline of hole with a pen or marker. Cut a hole in the blanket to match the hole in the Isokern top plate. Center the Iso-wool blanket over the Isokern Top Plate flue opening, then center anchor plate over the Iso-wool blanket. If a Damper is used, make sure nothing interferes with the damper plate movement.

Secure the Anchor Plate with minimum of four (4) masonry anchors (**Figure 49**). If the Anchor Plate with Damper is installed, the damper should swing freely. When the chain is pulled down, the damper should close (horizontal position). When the chain is released (no weight on the chain), the damper should swing open (vertical position).

To install the lintel hook, place the damper plate in the closed (horizontal) position. Determine and mark the position of the lintel hook. The lintel hook should be mounted in a position so as to provide a small amount of tension in the spring attached to the chain.

The tension is needed to prevent the damper plate from rattling when closed. Mount the lintel hook to masonry with the screws provided. Do not obstruct oval openings in the anchor plate.

WARNING: Do not locate anchor plate with damper in a location inaccessible for inspection, cleaning, and servicing after installation.

2. Attach Chimney: Attach the first section of chimney on the Anchor Plate. The joint assembly is male to female slip fit and held together with tab-lock, twist lock, or screwed together (**Figure 50**).

If installing screws, do not penetrate the inner liner of the chimney with screws. Maintain a two-inch (2") clearance to combustibles. Do not fill the clearance space with any materials. If an offset is required, refer to Elbow Offset Installation Section.

3. Frame Openings: From the ceiling, drop a plumb bob to the center of the fireplace's flue outlet and mark the center point on the ceiling. See **TABLE 1**.

Mark appropriate cutting lines around the center point. Cut a square hole in the ceiling. Frame a level, and square opening centered over the hole that you have cut. Frame openings at each floor level above the fireplace (**Figure 51**). These openings are to hold the Firestop and Attic Insulation Shield. Locate each opening by dropping a plumb bob to the four corners of the opening below. Maintain the two-inch (2") airspace to combustibles (**Figure 52**).

FIGURE 49

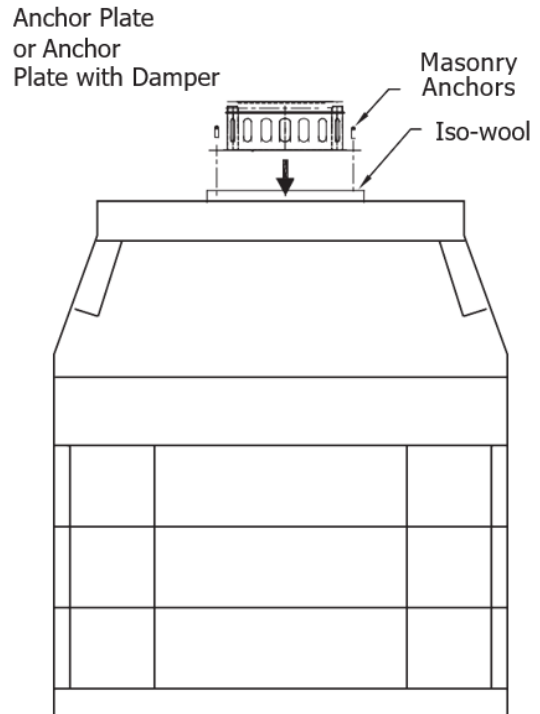
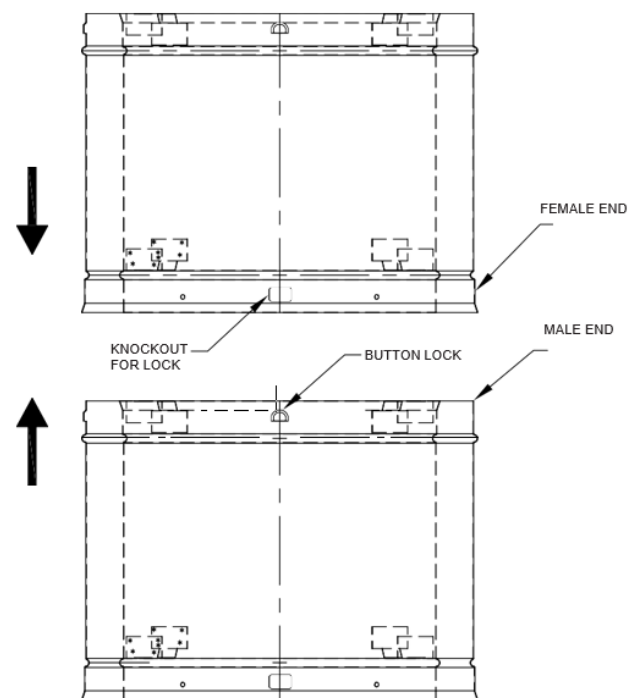


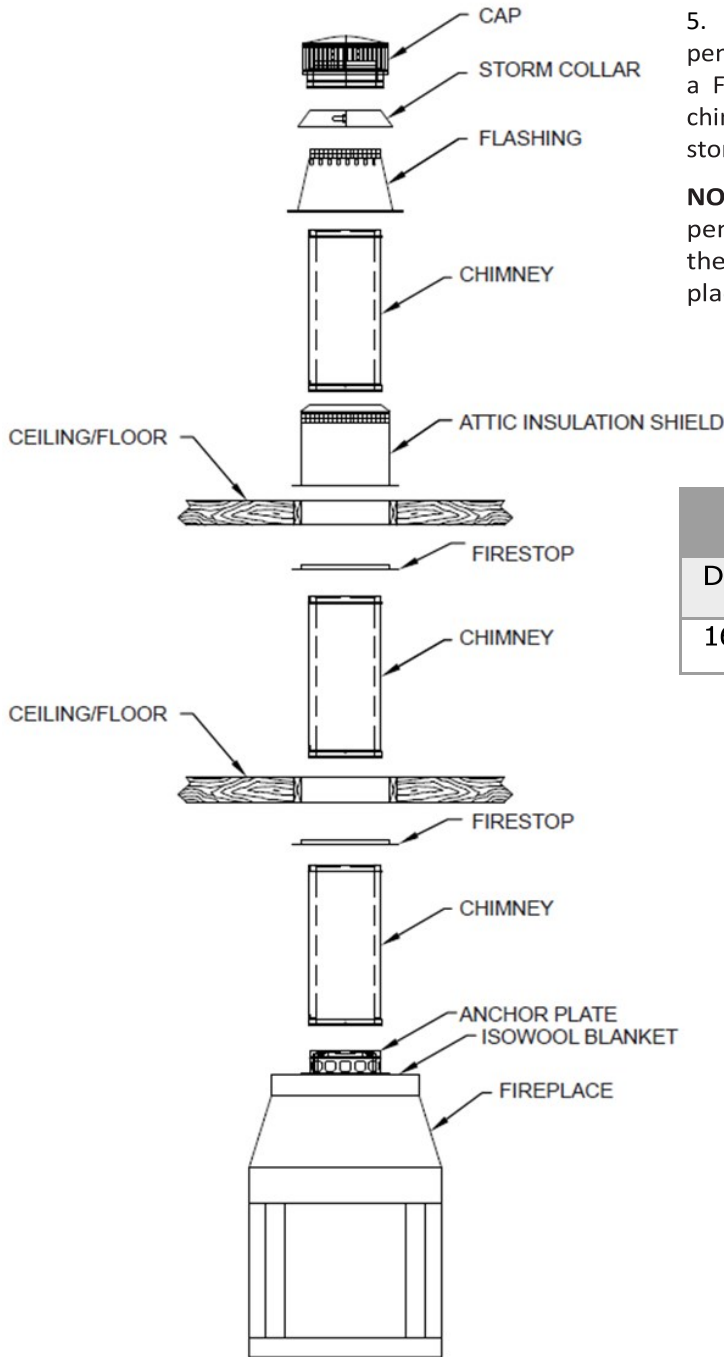
FIGURE 50



Eco-Steel Design Only

ECO-STEEL METAL CHIMNEY INSTALLATION

FIGURE 51



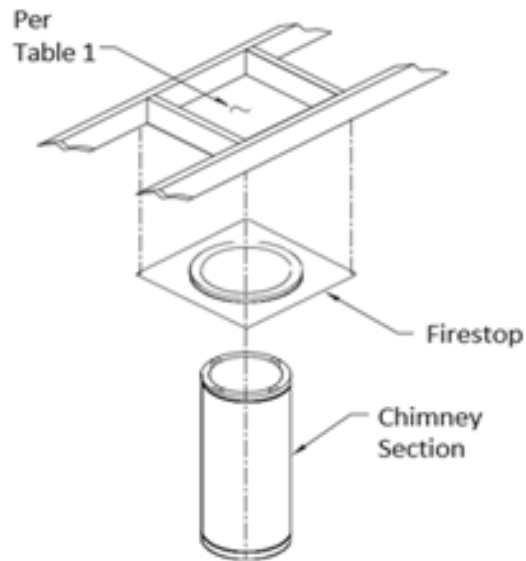
4. **Cut Roof Opening:** If penetrating through the roof, determine and cut an opening in the roof directly above the opening below. The cut opening must be 4" larger than the chimney's outside diameter to provide at least a two-inch (2") clearance all around the chimney. The chimney must be centered in this opening.

5. **Install Firestop:** A Firestop is required on each floor penetration in multistory installations. Building codes require a Firestop at every floor/ceiling level, including where the chimney penetrates the attic. **Figure 51** shows a typical two-story installation with an attic.

NOTE: A Firestop is not installed where the chimney penetrates through the roof. The Firestop is installed on the underside of the ceiling/floor framing and secured in place with nails or screws (**Figure 51**).

TABLE 1. Frame Opening Dimensions	
Diameter	Framing Dimensions
16" OD nominal	20" X 20"

FIGURE 52

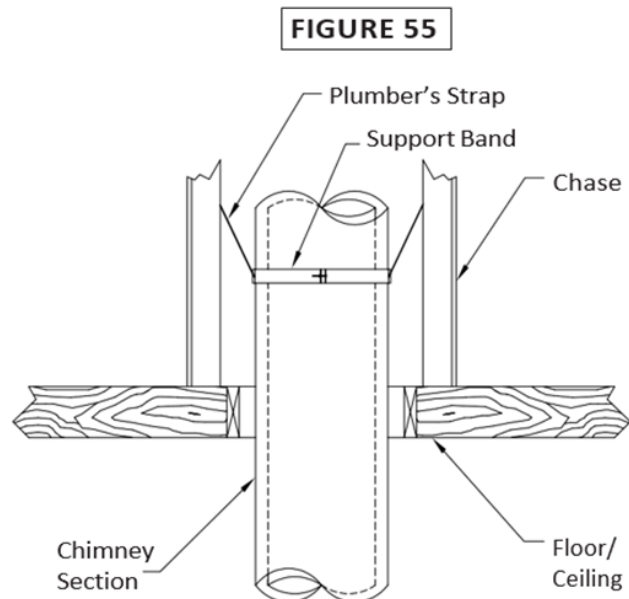
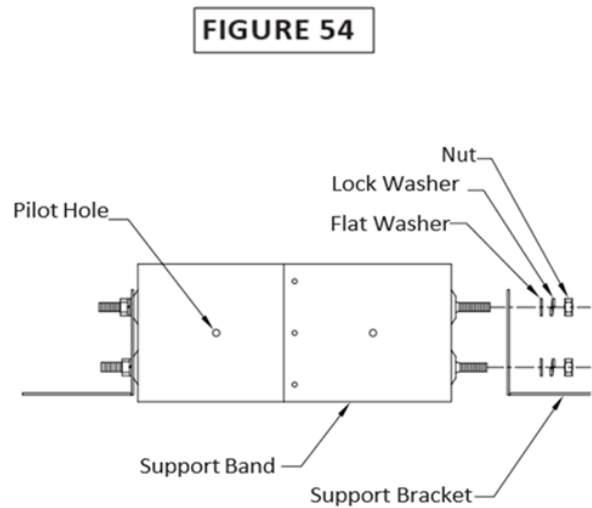
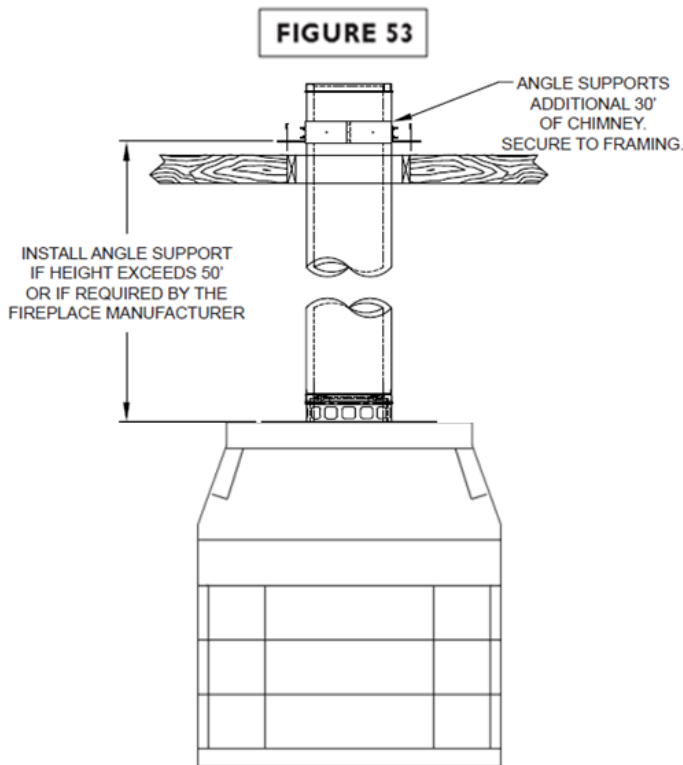


ECO-STEEL METAL CHIMNEY INSTALLATION

6. Angle Support and Support Band: Install an Angle Support if total chimney height is greater than 50 feet, or if the fireplace manufacturer requires it. If additional support is needed, install one or more Angle Supports, which will support 30 feet of chimney (**Figure 53**)

Slide the Angle Support around the chimney and align over framed opening. Secure to casing with four (4) sheet metal screws and assemble brackets (**Figure 54**). Nail the brackets to the framing using a minimum of (2) nails or screws per bracket.

A Support Band may be required by some fireplace manufacturers to keep the chimney vertical and help maintain clearances to combustibles within a chase. Clamp the Support Band to the pipe using the nut and bolt provided and secure legs to nearby framing using plumbers strap or guy wires (**Figure 55**). The Support Band does not support the weight of the chimney; it is only used to keep the chimney centered within a chase.



ECO-STEEL METAL CHIMNEY INSTALLATION

7. Attic Insulation Shield: The Attic Insulation Shield must be installed where the chimney passes into an attic. Its purpose is to maintain clearances from loose packed or blown insulation from the chimney. If an Attic Shield is not used the chimney needs to be enclosed within a framed enclosure. Always maintain a 2" air-space clearance to combustibles. Install the shield as follows:

- Remove any insulation or debris from attic floor around the framed opening.
- Assemble chimney sections above the Firestop to a height that extends beyond the height of the attic insulation shield.
- Slip the Attic Insulation Shield over the chimney until the base sits squarely on the framed opening.
- Secure the Attic Insulation Shield to the top of the framed opening using nails or screws (**Figure 56**).

8. Elbow Installation: 15° and 30° elbows are provided to allow chimneys to avoid framing members or roof peaks. A maximum of 30° from vertical is allowed and a total of four 30° elbows (4 elbows) for each chimney installation on naturally drafting fireplaces. A 2" clearance to combustibles must be maintained. If more than two offsets (4 elbows) are needed, a mechanical exhaust fan shall be used. The mechanical fan company would determine the viability of performance.

Attach the elbow to the chimney pipe, support, or other part. Using the offset chart, add chimney sections between elbows (**TABLE 2**). A **Support Band or plumbers strap is required for every 4-foot interval between elbows to support the load (Figure 57)**. Attach the upper elbow to bring the chimney back to vertical. See **TABLE 2** and (**Figure 57**) for offset combinations – 2 offsets (4 elbows) maximum.

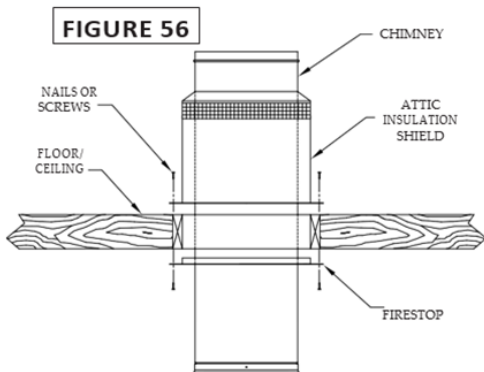
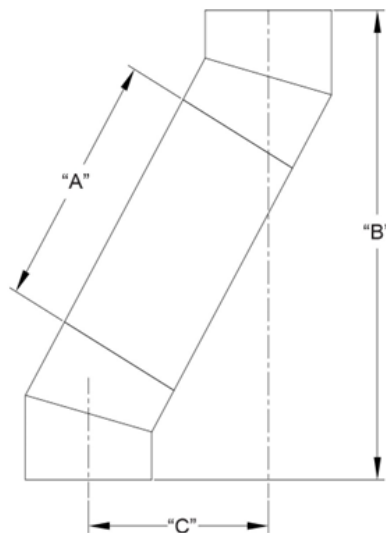
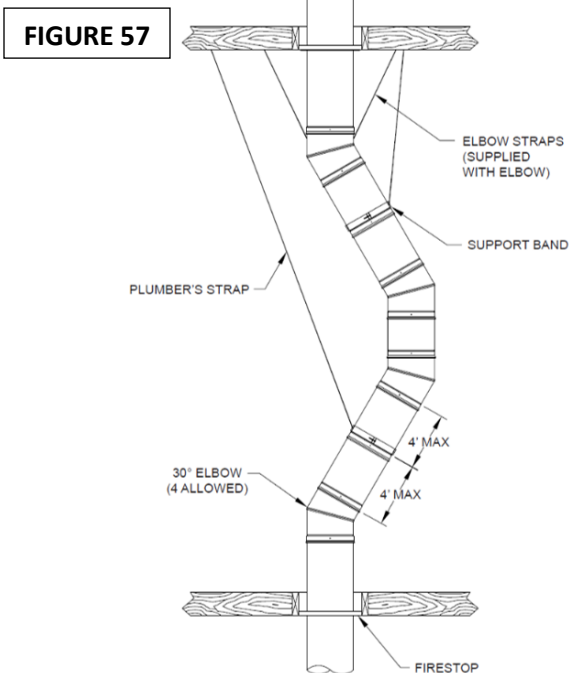


TABLE 2. OFFSET COMBINATIONS

		8" Diameter		10" Diameter		12" Diameter		13" Diameter		14" Diameter		16" Diameter	
Elbow Angle	Length "A"	"B"	"C"	"B"	"C"	"B"	"C"	"B"	"C"	"B"	"C"	"B"	"C"
15°	0"	19-1/4"	2-3/8"	19-3/4"	2-1/2"	20-1/4"	2-1/2"	20-1/2"	2-1/2"	20-3/4"	2-1/2"	21-1/4"	2-5/8"
	12"	29-1/4"	5"	29-3/4"	5-1/8"	30-3/8"	5-1/4"	30-1/2"	5-1/4"	30-3/4"	5-1/4"	31-3/8"	5-3/8"
	18"	35"	6-5/8"	35-5/8"	6-3/4"	36-1/8"	6-3/4"	36-3/8"	6-3/4"	36-5/8"	6-3/4"	37-1/8"	6-7/8"
	24"	40-7/8"	8-1/8"	41-3/8"	8-1/4"	41-7/8"	8-1/4"	42-1/8"	8-3/8"	42-3/8"	8-3/8"	42-7/8"	8-3/8"
	36"	52-1/2"	11-1/4"	53"	11-3/8"	53-1/2"	11-3/8"	53-3/4"	11-3/8"	54"	11-1/2"	54-1/2"	11-1/2"
30°	0"	21-1/8"	5-1/4"	22-1/8"	5-5/8"	23-1/8"	5-7/8"	23-5/8"	6"	24-1/8"	6-1/8"	25-1/8"	6-3/8"
	12"	30-3/8"	10-5/8"	31-3/8"	10-7/8"	32-3/8"	11-1/8"	32-7/8"	11-1/4"	33-1/8"	11-3/8"	34-1/8"	11-5/8"
	18"	35-1/2"	13-5/8"	36-1/2"	13-7/8"	37-1/2"	14-1/8"	38"	14-1/4"	38-3/8"	14-3/8"	39-3/8"	14-5/8"
	24"	40-3/4"	16-5/8"	41-3/4"	16-7/8"	42-3/4"	17-1/8"	43-1/4"	17-1/4"	43-1/2"	17-3/8"	44-1/2"	17-5/8"
	36"	51-1/8"	22-5/8"	52-1/8"	22-7/8"	53-1/8"	23-1/8"	53-5/8"	23-1/4"	53-7/8"	23-3/8"	54-7/8"	23-5/8"
48"	61-1/2"	28-5/8"	62-1/2"	28-7/8"	63-1/2"	28-1/8"	64"	29-1/4"	64-3/8"	29-3/8"	65-3/8"	29-5/8"	



ECO-STEEL METAL CHIMNEY INSTALLATION

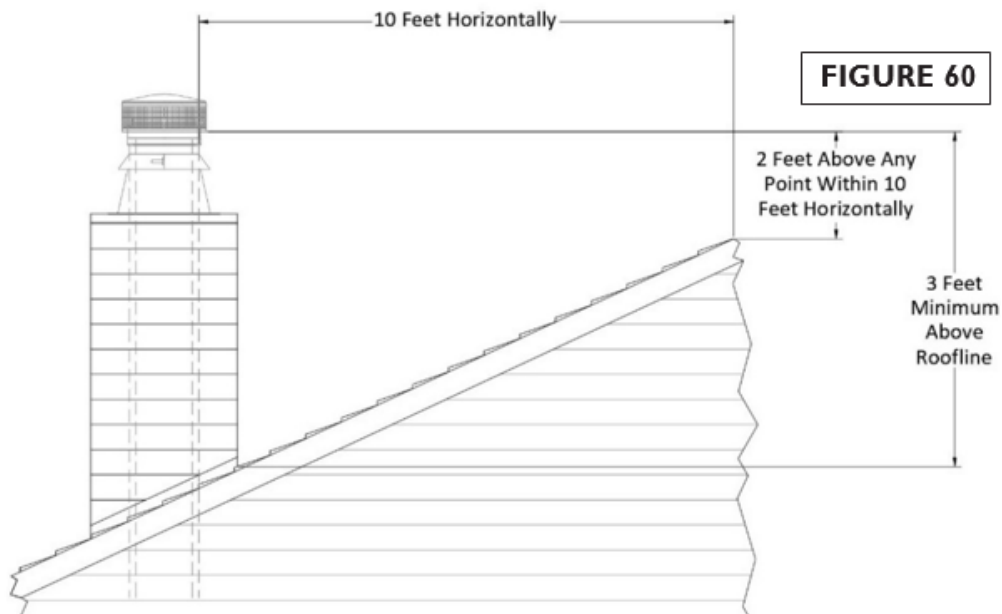
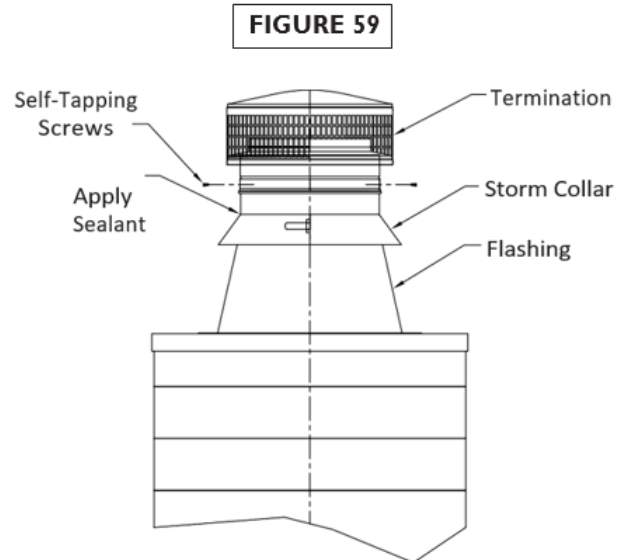
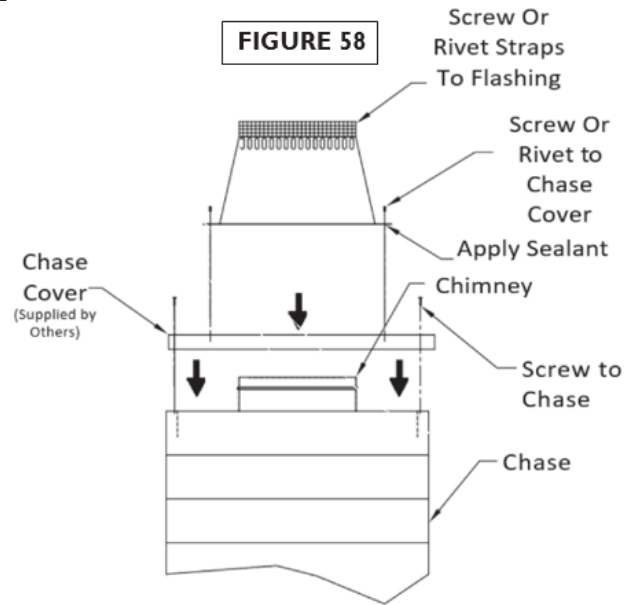
9. For chase enclosures, install the chase top cover (supplied by others) to the chase enclosure. Cut a hole in the chase top cover the same diameter as the base of the cone on the flashing. Attach the Flashing to the top of the chase cover, sealing with a non-hardening waterproof sealant. Secure in place with screws or rivets (Figure 58).

10. Attach the storm collar around the chimney above the screen of the flashing. Secure in place with the locking tab and button. Seal around the storm collar with a non-hardening waterproof sealant. Attach the Termination Cap to the chimney by sliding the male to female joint connection together and secure in place with four (4) sheet metal screws provided (Figure 59).

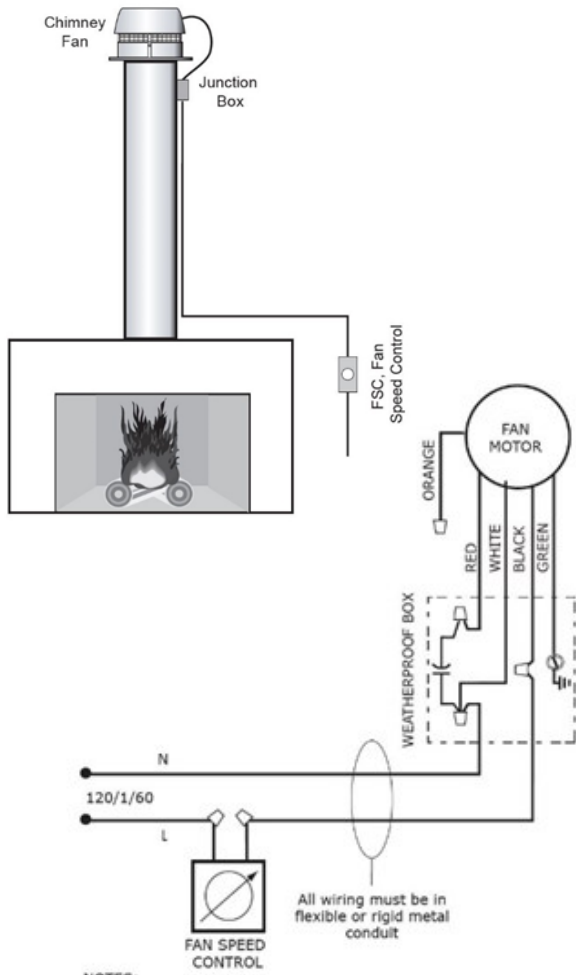
11. Termination: NFPA 211, "Standard for Chimneys, Fireplaces, Vents, and Solid Fuel- Burning Appliances," states that chimneys shall extend at least three feet above the highest point where it passes through the roof of a building, and at least two feet higher than any portion of a building within ten feet (Figure 60).

If the horizontal distance from the chimney edge to the peak of the roof is greater than 10', a chimney height reference point is established on the roof surface 10' horizontally from the chimney edge. The top of the chimney (point where exhaust gases exit) must be at least 2' above this reference point. In all cases, the chimney must terminate a minimum of 3' above the highest point of the roof opening. (Figure 60)

The ten-foot rule is necessary in the interest of safety and does not ensure smoke free operation. Trees, building, adjoining rooflines, adverse wind conditions, etc., may require a taller chimney should a smoking problem exist.



Guide for Mechanical Draft System



NOTES:

- 1 THE DISCONNECT MEANS AND CIRCUIT PROTECTION ARE TO BE PROVIDED BY THE INSTALLER OF THIS DEVICE

LEGEND:

—	24 VAC
—	120 VAC

Note: The diagram is for reference only. Job specific wiring diagrams can be provided by ENERVEX.

Mechanical Draft System for Wood and Fired Fireplace with a Single Flue

Application: This is the most common form of installation and is used in all jurisdictions where the 2000 or later edition of the NFPA211 has not yet been adopted.

Sequence of operations:

1. Prepare the wood logs in the fireplace.
2. Turn the Fan Speed Control (FSC) on by turning the knob clockwise. A "click" indicates the control is turned on. Adjust the knob to the desired speed.
3. Start the fire by igniting the logs.
4. Once the fire is fully burning, turn the dial clockwise (to reduce the speed) until there is spillage coming from the fireplace is an indication of spillage. From this point,
5. gradually increase the fan speed by turning the dial counterclockwise until no flue gases spill from the fireplace. This dial can be left in this position.
6. If logs are added to the fire, it may be necessary to increase the fan speed again.
7. When the fire is dying, reduce the speed setting further to remove remaining products of combustion.

IMPORTANT NOTE: Never leave a fire unattended. When a fire is smoldering, it is more likely to emit carbon monoxide. You should always have a smoke detector and a carbon monoxide detector installed in the same room where the solid-fuel burning appliance is installed.

The system consists of the RSHT Chimney Fan, the Manual Fireplace Damper (MFD), and Fan Speed Control.

RSHT Chimney Fan

The RSHT Chimney Fan is a high-temperature fan used to maintain the proper draft in a solid fuel chimney or stack system. It is intended for wood burning fireplaces. It boasts a 1000°F temperature rating. The FSC variable Fan Speed Control comes standard with the fan.

Manual Fireplace Damper

The MFD-S Fireplace Damper for solid fuel prevents conditioned air from escaping through the chimney when the fireplace is not in use and prevents backdraft down the chimney. It includes an easy-open pull cable and handle that is mounted inside the fireplace.

Fan Speed Control

The FCS Fan Speed Control is used in conjunction with all single-phased chimney fans. It is specially engineered to provide variable speed control of split capacitor motors.

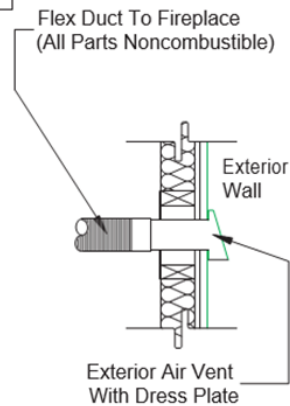
COMPONENT	PART#	DESCRIPTION
	RSHT	1600 RPM High Temperature Chimney Fan
	MFD-S	Manual Fireplace Damper
	FSC	Fan Speed Control (included w/fan)

Access Modification - Combustion Air Kits, Gas & Electrical Line Feed

A four inch (4") supplemental combustion air inlet kit may help improve fireplace operation in homes tightly sealed and with other ventilating appliances installed (**Figures 61 & 62**). The following is a general representation of a combustion air kit.

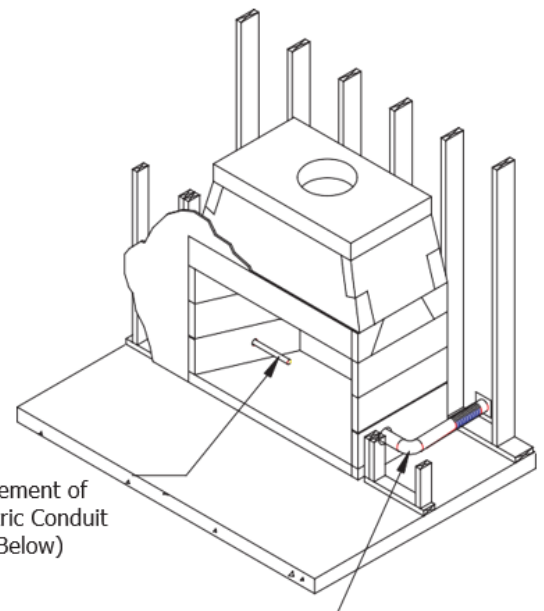
The air kit is fitted into the front 1/3 of the side wall by core drilling an appropriately sized hole at the selected firebox location. Keep the top of the access hole no more than six inches (6") above the finished firebrick floor. The hole size should allow for a quarter-inch (1/4") joint around the air access sleeve for heat expansion. Do not install in the rear of the firebox. Combustion air kits must be installed in accordance with local codes.

FIGURE 61



Fireplace Make Up Air Requirements	
Model #	Consumption Air Flow (CFM)
80S36	363
80S42	424
80S46	464

FIGURE 62



CAUTION:

All access holes must be properly sealed after firebrick installation

WARNING!!! Do not use combustible duct material. Avoid installing a combustion air inlet where the opening could be blocked by snow, bushes, or other obstacles. Air inlet ducts shall not terminate in attic, basement, or garage spaces.

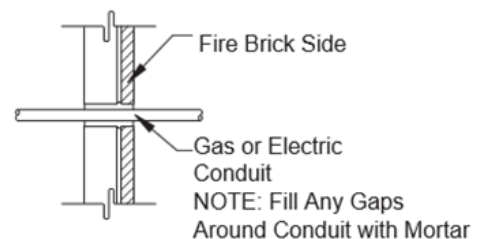
Gas Line Feed: For a fireplace having the provision for installation of a gas pipe, the provision is intended only for connection to a decorative gas appliance.

CAUTION: When using the decorative appliance, the fireplace damper must be locked in the fully open position. Gas line for gas log sets used in the Isokern firebox can be routed through the side wall, by drilling an appropriately sized hole using a masonry drill bit (**Figure 62**).

Electrical Line Feed: The line can be routed through the STANDARD firebox side walls by drilling an appropriately sized hole using a masonry drill bit (**Figure 63**). Be sure to follow the gas log appliance manufacturer's explicit electrical line connection instructions for vented masonry fireplace installations. Gas line and electric line must be fed through separate access holes.

CAUTION: All access holes into the firebox must be grouted with mortar – after line or conduit feed – to seal any gaps or cracks around line feed conduits (**Figure 61, 62, 63**).

FIGURE 63



Firebrick Installation

FIGURE 64

The expansion joint in this illustration is on the hearth.

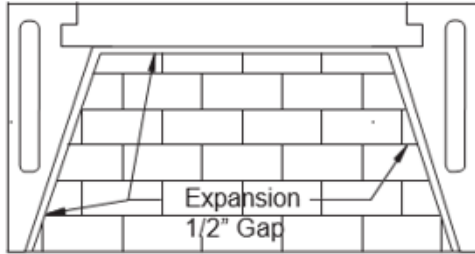
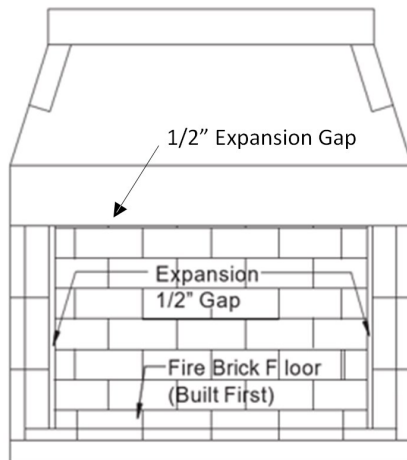
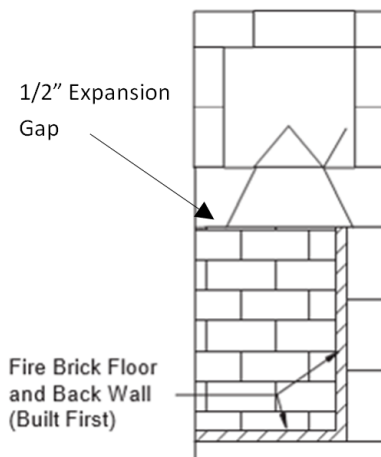


FIGURE 65



The expansion joint in this illustration is on the backwall.

FIGURE 66



The manufacturer requires the STANDARD fireplace series be lined with a minimum 1-1/8" thick firebrick. Thicker firebrick may be used as an option. The pattern for the firebrick lining is an owner option. The ISOSET mortar by Earthcore is to be used when lining the Isokern Fireplace.

The ISOSET Firebrick Mortar Application:

- Add 0.75 quart of water per 10 lbs. of dry product until completely blended.
- Only mix what can be utilized within 15 minutes.
- Do not retemper (the addition of water after the chemical reaction has begun).
- The use of warm water will accelerate setup.
- Joint thickness should be thin (1/4" - 3/8").
- Complete set time is between 48 and 72 hours.
- For best results, please allow 28 days before heat is applied.
- Approximately 35 to 40 lbs. of prepared mortar will lay up one hundred 9" x 4-1/2" x 2-1/2" Straights.
- **DO NOT add additives, such as fireclay, sand, cement, or other accelerators.**

NOTE: These instructions may vary because of different climates and conditions. The use of good masonry practices for your area should also be considered

Installation Instructions:

1. Wet mop the inside of the fireplace with a damp sponge to remove dust and loose particles from the interior before installing firebrick. Keep the fireplace damp while installing firebrick.

For Best Results:

- After wetting interior of firebox, apply a 3/8" notch bed joint on rear sides and floor.
 - Dip each firebrick in a pale of water before applying mortar to one side for adherence to firebox.
2. Face joint dimensions of 1/4" to 3/8" in the brick work are recommended and have the best appearance. Other face joint dimensions are acceptable, however smaller joints may not leave room for heat expansion of firebrick.
 3. Start the firebrick at the front edge of the floor of the Isokern firebox, proceeding inward toward the back. Leave a 1/2" expansion gap between the firebrick and the side and back walls. This air space allows heat expansion of the firebrick and is to be left empty of mortar (**Figure 64**).
 4. Next, apply firebrick to the back wall of the unit. The back wall firebrick covers the 1/2" expansion gap left at the brick floor along the back wall of the firebox. Leave a 1/2" expansion gap at the sides and top (**Figure 65**).
 5. Set the side wall firebrick by starting at the front edge of the unit's side wall and working inward toward the backwall firebrick. The side wall firebrick, when completed, covers the 1/2" expansion gaps where both the floor firebrick and the backwall firebrick were held off the unit's side walls (**Figure 66**). Leave 1/2" expansion gap at top.

All required through-wall accesses (gas and air intake supply access holes) should be drilled before the required firebrick lining is installed. Do not cover these areas with firebrick.

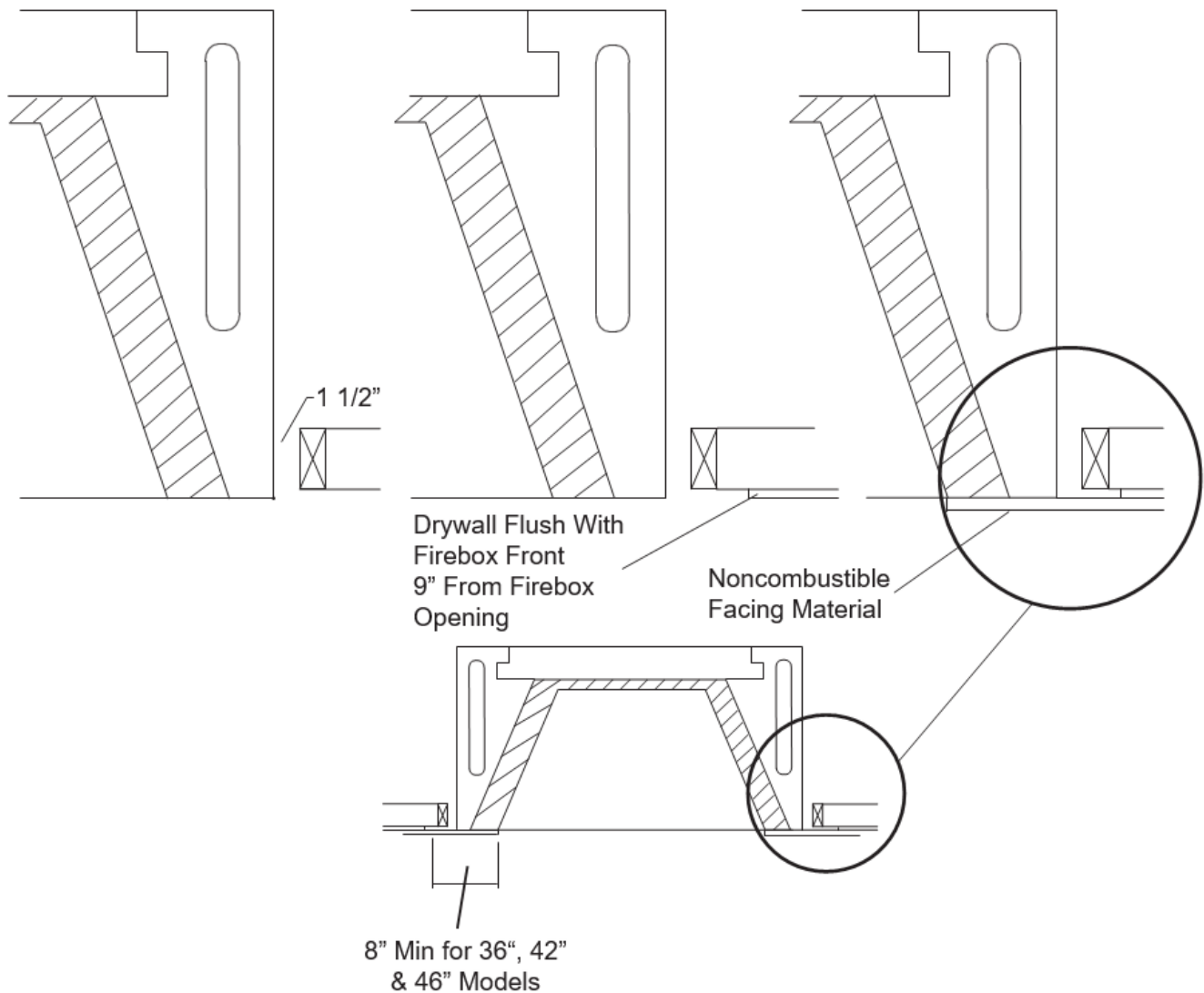
Earthcore makes no claims as to the performance of firebrick or firebrick mortar(s). It is typical for heat stress cracks to appear in the firebrick in fireplaces.

Flush Wall Finish Detail

When drywall is the wall finish at the STANDARD face and flush with the rough face of the STANDARD firebox and damper beam, it is recommended when installing the required firebrick lining to the interior of the firebox, that the leading edge of the firebrick – at the floor and at the side walls of the firebox – be set flush with the STANDARD’s rough firebox front. This will aid in the overall fit and finish of the STANDARD Series fireplace front when the code required non-combustible finished facings are applied.

This alignment of firebrick application, as shown below (**Figure 67**), allows the firebrick lining to be in the same plane with the room’s wall finish surface. With the firebrick set in this fashion the non-combustible finish facing material can be set tight against the leading edge (or “room edge”) of the firebrick at the sides of the fireplace opening. At the same time, the finished facing material can lay flat against the room’s finished wall surface.

FIGURE 67



Clearance to Combustible Trim - 36, 42 & 46 Models

Hearth Extensions

All STANDARD 36, 42, and 46 Fireplaces shall have hearth extensions of brick, concrete, stone, tile, or other code approved non-combustible material. Suitable hearth extension material for the fireplaces shall be placed on the hearth extension's non-combustible substrate and must extend to at least twenty inches (20") in front of the fireplace's finished opening and must extend to at least twelve inches (12") beyond the sides of the finished fireplace opening (**Figure 68**).

WARNING: The non-combustible hearth extension, by code, must sit on non-combustible substrate, which shall have no wood underpinning. This means that off-grade wood floor systems shall be constructed in such a way that all wood floor joists, and sub-flooring shall stop twenty inches (20") out from the front of the firebox (**Figure 69**).

Mantel and Mantel Shelf Clearances

Fireplaces are subject to the same building code safety clearances to combustible trim as with any radiant heat fireplace.

All combustible trim shall be kept at least eight inches (8") from the finished fireplace opening.

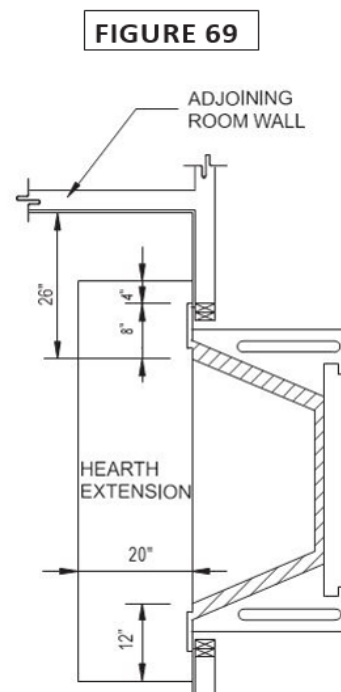
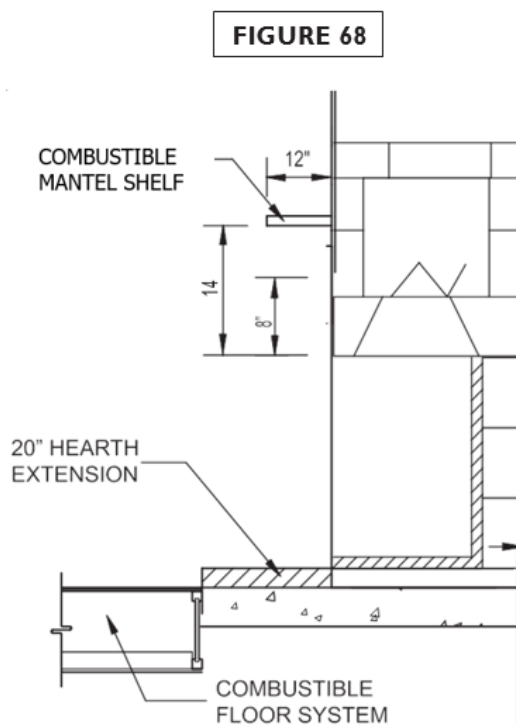
Combustible trim located along the sides of the fireplace opening, which project more than one and a half inches (1-½") from the face of the fireplace, shall have additional clearance from the eight inches (8") equal to the projection.

Combustible projecting mantels – up to twelve inches (12") of projection – shall not be placed less than fourteen inches (14") from the top of the fireplace opening. Combustible mantels, which project more than twelve inches (12") from the face of the fireplace, shall have additional clearance from the fourteen inches (14") equal to the projection.

NOTE: The local authority having jurisdiction may require greater clearances for projecting combustible mantel shelves. Be sure to check local building codes regarding required clearances to projecting combustible mantels.

Adjoining Walls: Side walls and walls to rooms adjoining fireplace installations cannot be closer than twenty-six inches (26") to the finished fireplace opening.

NOTE: "Clearance to Combustible Trim" are those distances required to ensure that a fireplace mantel or facing will not catch fire. In most cases, the distances should also be adequate to prevent any discoloration or warping due to heat. However, each installation presents a unique and completely different set of circumstances involving many variables. These include paint or finish composition, previous exposure to heat, methods and quality of construction, air flow patterns, etc. Because of these variables, the manufacturer does not guarantee that heat warping or discoloration will never occur.



Specialty Applications - Outdoor Installation

The Isokern fireplace can be used in an outdoor application and is considered an "Outdoor Application" if the fireplace is a freestanding unit, located a minimum of ten feet (10') away from any structure. These structures would include your house, patio cover, detached garage, or any other standing structure (**Figure 70**).

Selecting an Outdoor Location: To determine the safest and most efficient location for the fireplace, you must take into consideration the following guidelines:

1. The location must allow for proper clearances and venting.
2. Consider a location where the fireplace will not be affected by down drafts, impending structures, or frequently opened doors.
3. Avoid a location where the chimney termination will be near abrupt changes in the roof shape, nearby wall, under trees, or above the roof of a single-story wing of a two-story building.

Chimney Flue: Recommended minimum height of chimney, measured from base plate of the fireplace to flue gas outlet of termination, should be a minimum of 9- ½ feet. If the fireplace is located adjacent to structures on the property, the chimney height should be a minimum of two feet taller than that structure. The height of the chimney will require calculated dimensions to make sure the smoke vents properly upward through the chimney and doesn't create a downdraft that will push the smoke back out of the hearth.

The use of either the DM 54 or ECO-STEEL & ECO-STEEL+ Chimney flue are the recommended flue types for the STANDARD models in the outdoor application. If the use of ECO-STEEL & ECO-STEEL+ Chimney is used, a 2" clearance to combustible material is required. See page 37 for more information.

Supporting Footers: The STANDARD series fireplace must be built upon a concrete support slab with no wood underpinnings. In the outdoor application, careful load calculations should be made for the veneer type used on the fireplace as well as the chimney weight.

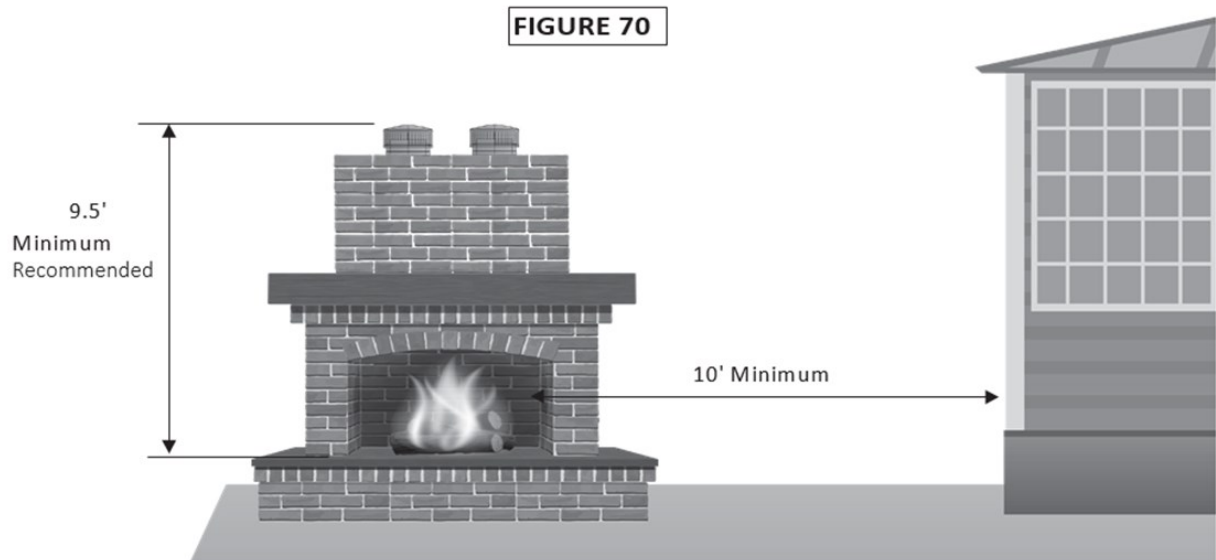
Foundations and footings must be made of a frost -protected foundation and be approved by the local building authority. For any foundation design and load requirements check with local structural engineer. **It is the responsibility of the General Contractor to ensure adequate foundations.** See page 16 for weight calculations.

IMPORTANT: Due to heat and weight issues, the Isokern fireplace and DM 54 chimney system installations require that the system be built upon a non-combustible concrete slab with no wood underpinnings supported to footings with concrete or steel and designed to carry the total weight of the Isokern fireplace and chimney system.

Assembly Instructions: Refer to the assembly instructions that are found on pages 21-25.

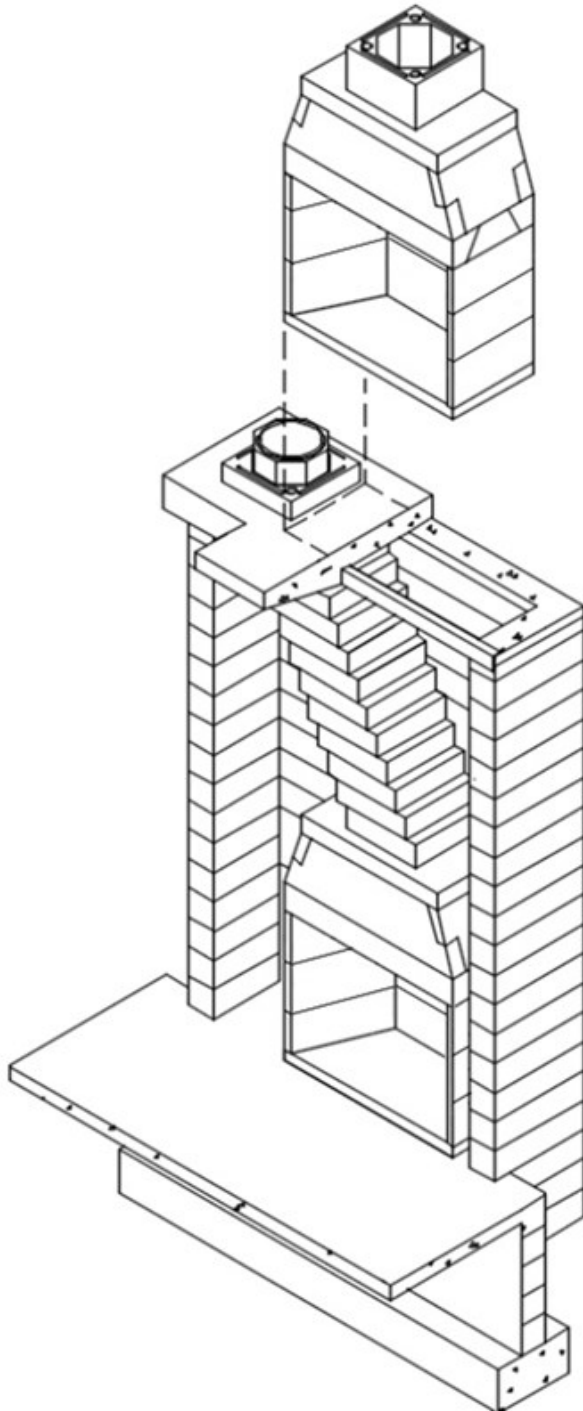
NOTE: A damper is not required in an outdoor application of the Isokern Fireplace.

Clearance to Combustibles: Follow the instructions on pages 14-15 on the Required Clearances to Combustibles.



Specialty Applications - Two-Story Stacked Installations

FIGURE 71



**General Representation Only!
Offset support not shown!*

General Information

To install one Fireplace and DM chimney system above one another, as in a two-story stacked installation, both the upper and lower fireplace installations require a structurally designed support down to footings designed by a structural engineer.

Frequently, in two-story stacked installations, the lower unit is supported by a slab-on-grade, whereas the upper unit is a typical off-grade support. The off-grade slab for the upper unit must be built with sufficient width in order to accommodate the width of the upper fireplace plus the width of the by-passing chimney system rising from the lower unit (**Figure 71**).

The slab for the lower unit will need to be built with enough width to provide support for the lower fireplace unit plus the bearing surface for the support columns needed to carry the offset chimney sequence of the lower system (**Figure 71**).

Floor-to-Floor Height Considerations

In order for the lower fireplace installation to have enough overhead height clearance for its chimney to rise at a thirty-degree (30°) angle of offset (maximum angle of offset as allowed by code) and bypass to one side of the firebox in the upper location, there are minimum required floor-to-floor height dimensions. (See chart, page 54 Column "F").

The minimum floor-to-floor height required for an installation is determined by calculating the total horizontal distance the lower flue must travel to the left or right for it to bypass to one side of the upper fireplace. (see calculating offsets on pages 30-32)

The total amount of horizontal chimney offset travel distance will be determined by two factors:

1. The width dimension of the upper unit; and
2. The horizontal distance between centerlines of the proposed upper and lower units.

Example: If the upper fireplace and the lower fireplace sit on the same centerline, then the required floor-to-floor dimension is at a maximum (See Figure 71 and chart on page 54; Column "F".)

For every 3" of horizontal distance separating the centerlines of the upper and lower units, the overall height of the offset sequence is reduced by one offset block or by 6".

Specialty Applications - Two-Story Stacked Installations

The following chart gives important dimensions needed when laying out two-story stacked fireplace units. Chart dimensions assume that both the upper and lower fireplace units sit on the same centerline.

NOTE: Widths of both Isokern STANDARD and MAGNUM fireplaces are the same. Only the depth of the firebox and the height of the finished opening differ.

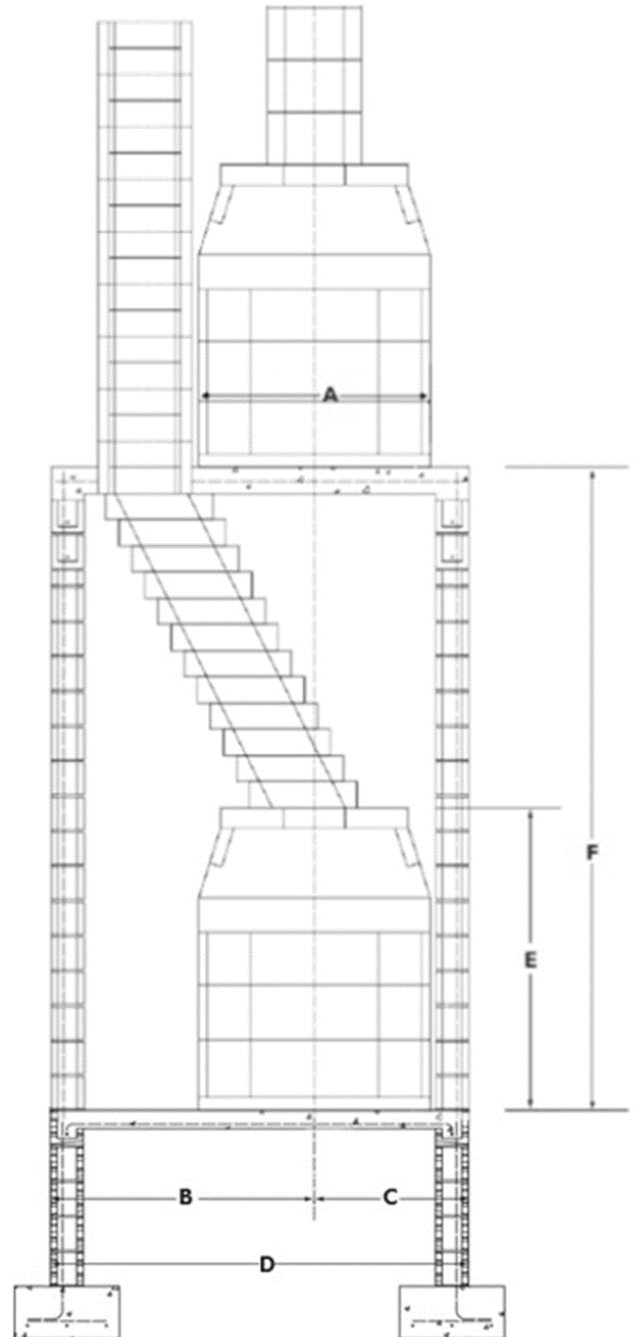
Fireplace Size Upper/Lower	A	B	C	D	E	F
36/36	43"	51"	30"	81"	63"	134"
36/42	43"	51"	33"	84"	63"	134"
36/46	43"	51"	35"	86"	63"	134"
42/36	49"	54"	33"	87"	63"	140"
42/42	49"	54"	33"	87"	63"	140"
42/46	49"	54"	35"	89"	63"	140"
46/36	53"	56"	35"	91"	63"	146"
46/42	53"	56"	35"	91"	63"	146"
46/46	53"	56"	35"	91"	63"	146"

Chart Dimension Description

- A:** Outside width dimension of the Fireplace model chosen for the upper unit.
- B:** Distance (taken in the direction of the chimney offset) from the centerline of the lower fireplace to the outside face of the eight-inch (8") thick bearing wall underpinning the upper unit's floor system.
- C:** Distance (taken away from the direction of the chimney offset) from the centerline of the lower or the upper fireplace, whichever is the larger, plus eight inches (8") to the outside of the eight-inch (8") thick bearing wall for the upper unit's support slab.
- D:** Outside-to-outside dimension of the two eight-inch (8") thick bearing walls underpinning the upper unit's support slab. "D" is also the width of the upper unit's support slab and includes the additional space for the width of the DM chimney as it bypasses the upper unit. "D" is also the sum of "B" plus "C."
- E:** Height of the Fireplaces chosen for the lower unit and includes the Isokern three-inch-thick base plate.
- F:** Distance from the top of the support slab of the lower unit to the top of the floor of the upper unit.

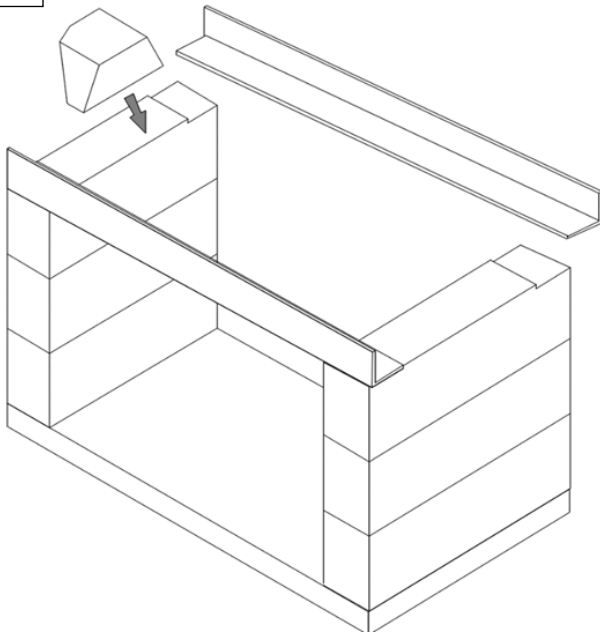
IMPORTANT: If raised hearths are planned for the lower unit, then "F" dimension will increase by the height of the raised hearth at the lower unit.

FIGURE 72



Specialty Applications – See-Thru Application

FIGURE 73



See-Thru or two-sided STANDARD fireplaces can be custom ordered through your Isokern representative. The following directions are to demonstrate how to place the steel angle iron on the front and back of the sidewalls or backwalls before the damper beams are set and the smoke dome is constructed. **When installing a See-Thru Application Fireplace, a Mechanical Exhaust Fan is highly recommended.**

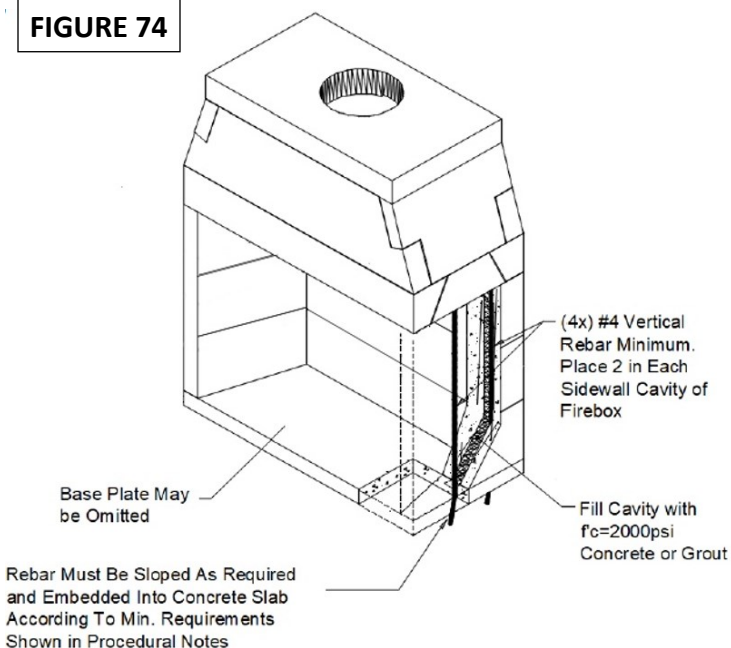
NOTE: Two pieces of steel angle iron four inch by four inch by three-eighths inch (4" x 4" x 3/8") cut to span the firebox openings should be set on top of the side wall assembly on both sides before the damper beams and smoke dome assembly. **(FIGURE 73)**

Notch the ends of each new sidewall or backwalls thickness of the steel as shown. Each end of the steel angles must bear fully at least 3" onto the side wall assembly.

Minimum Rebar Requirements

Bar Size	Rod Size (inches)	Bit Dia. (inches)
#3	-	1/2
#4	1/2	5/8
#5	5/8	3/4
#6	3/4	7/8
-	7/8	1
-	1	1-1/8

FIGURE 74



Seismic Requirements (Slab On Grade)

PROCEDURE:

1. Drill hole of proper diameter and depth using a carbide tipped drill or coring bit. Avoid any existing reinforcing steel by relocating hole slightly. (Figure 74)
2. Clean hole thoroughly by vacuum or air pressure.
3. Make sure that hole is dry and clean before grouting.
4. Place epoxy grout in hole with caulking gun or similar equipment starting at bottom, fill hole approximately 2/3 full.
5. Coat dowel with same epoxy grout and insert into hole, forcing material around the sides of the bar and completely filling all voids.
6. Provide support for dowel by trying to rebar or another element until grout has cured.
7. Epoxy grout in CMU shall be Simpson set epoxy tie (ESR-1772), Hilti HIT-HY 150 max. (ESR-1967), or equal.
8. Epoxy grout in concrete shall be hit-re 500-SD by Hilti corporation. (ESR-2322), Simpson set-xp (ESR-2508) or equal.
9. Special inspection required.

Summary

1. Chimney Installation and Draft

Chimney systems will only draft properly when they are installed according to the instructions in an appropriate location and with the proper chimney height. Installing the fireplace according to the instructions, choosing an appropriate location, and choosing an appropriate chimney height are the responsibility of the designer and the building contractor.

Tightly insulated and sealed homes, two-story interior spaces, and high-vaulted ceilings can cause negative air pressures within the house, which can impair drafting performance. HVAC return air ducts near the fireplace opening will adversely affect the fireplace drafting performance.

It is the responsibility of the designer, the building contractor, and their mechanical contractor to determine that the building's internal air pressures are conducive to positive fireplace drafting.

Avoid placing any fireplace in an area near tall trees, tall buildings, or high land masses. These structures can reduce ambient air flow pressure as well as produce down drafts, either of which can impair fireplace drafting performance.

Earthcore Industries L.L.C. does not warrant drafting and is not responsible for it.

2. Fireplace Curing Instructions

It is critical that the Isokern masonry elements in the firebox and smoke dome assembly be dry before firing of the unit. Moisture left in the components from exposure during storage and shipping, as well as moisture from the installation phase, must be eliminated before the unit is put to its intended use.

The first step in reducing the ambient moisture is to be sure that the completed fireplace rest totally in a dried-in setting for a minimum of 28 days after construction of the unit is complete.

The next step in curing the fireplace is to be sure that the first five or six fires are of short duration. The first fire of the unit can take place once the minimum 28-day drying period has passed. This fire should be especially short.

Start the first fire slowly with a small amount of paper and kindling (small dry wood splits or twigs) and a maximum load of four to six pounds of dry firewood, estimated to be no more than two or three logs, each of about three inches (3") to four inches (4") in diameter. The first fire should burn for no more than 30 to 60 minutes and then allowed to go out. Do not refuel the fireplace during the first lighting. A cooling-off period of 24 hours, at a minimum, should follow the first fire.

The second fire should be the same as the first fire. It should burn for no more than 30 to 60 minutes and allowed to go out. Do not refuel the fireplace during the second lighting. A 24-hour cooling-off period must be observed following second lighting.

After the first and second fires, continue use of the unit with three or four small fires of short duration (60 minutes or so) and small fuel load.

After these first five or six small fires of short duration, normal use of the fireplace can proceed. For normal use, the maximum recommended fuel load is 12 to 16 pounds of dry firewood at a time. This fuel load is considered to be approximately three to five cured hardwood logs of about three inches (3") to six inches (6") in diameter. As the fire burns down, refueling should be only one or two logs added at a time.

IMPORTANT: Do not burn construction debris or trash of any kind in the fireplace. Whereas it is not uncommon for construction debris and refuse to be burned in a fireplace by site personnel on a project that is under construction, this activity must be avoided. It is the responsibility of the building contractor to ensure that the required dry-in period is met and that the required lighting sequence is performed by the owner or by the owner's agent.

3. Log Grates

Log grates are required for burning solid fuel in the Isokern fireplace. Grates allow for easy air flow up through the burning logs, thus creating a more complete and efficient burning of the fuel.

Summary

4. How to Build a Fire

First, set the fireplace damper in the fully open position. Begin laying the fire by placing several pieces of wadded up paper directly on the log grate. Place kindling (small splits of dry pine or other dry softwood) on top of the paper, enough to loosely cover the paper. Next, arrange several small, dry hardwood or softwood logs or log splits on top of the kindling layer.

Finally, arrange two or three larger hardwood logs (oak, hickory, etc.) or log splits on top of the stack.

Ignite the paper at the bottom of the stack. The burning paper will ignite the kindling, which will, in turn, set the remaining fuel on fire.

Be sure to stack all firewood in such a way that it will settle into the log grate as the paper and kindling layers are burned away. Additional logs can be set onto the fire as each fueling burns down.

Ideally, fuel logs should be of a hardwood species that have been air dried for one year or longer. Use of cured or uncured pine logs and uncured hardwood logs for fuel should be avoided. Pine logs and uncured hardwood logs will tend to smolder and burn at relatively low temperatures, producing high levels of soot and creosote.

IMPORTANT: Do not throw, toss, jam, kick, or otherwise force logs into the Isokern fireplace.

WARNING: Never use gasoline, gasoline type lantern fuel, kerosene, charcoal lighter fluid, or other similar liquids to start or “freshen up” the fire in this fireplace or in any fireplace.

WARNING: If processed solid fuel fire logs are used: Do not poke or stir the logs while they are burning. Use only fire logs that have been evaluated for the application in fireplace and refer to fire log warnings and caution markings on packaging prior to use.

5. Avoid Over-firing this Fireplace.

Some examples of over-firing are:

- Burning of scrap lumber, construction debris, pine branches and brush or cardboard boxes.
- Burning small diameter twigs, branches, or any other small sized combustible materials in quantities, which exceed the volume of the normal log fire.
- Use of artificial wax base logs, trash or other chemicals or chemically treated combustibles.

WARNING: Over-firing can permanently damage this fireplace system.

6. Disposal of Ashes

It is recommended that the firebox be cleaned of excessive ashes before each use. It is necessary to remove ashes from the open front of the fireplace. To do so, proceed in the following manner:

Allow the fire to go out and the ashes to cool for at least 6 to 8 hours.

After the cooling period, carefully pick up the ashes from the firebox with a small, metal fireplace shovel, or other metal scoop and place them in a metal container with a tight-fitting lid.

If possible, do not sweep the ashes as this will stir them into the air and disperse them into the room.

The closed container of ashes should be placed on a non-combustible floor or on the ground, well away from all combustible materials, pending final disposal. If the ashes are disposed of by burial in soil or otherwise locally dispersed, they should be retained in the closed container until all cinders have thoroughly cooled.

Summary

7. Gas Log Sets

If you install a vented gas log set (decorative gas appliance), the log set must comply with the Standard for Decorative Gas Appliance for Installation in Solid Fuel Burning Fireplaces, ANSI Z21.60 or Z21.84 and shall also be installed in accordance with the National Fuel Gas Code, ANSI Z223.1/NFPA 54 latest edition.

If you wish to install an unvented (vent-free) gas log set, only unvented gas log sets that have been found to comply with the standard for unvented room heaters, ANSI Z21.11.2 are to be installed in this fireplace. Check local codes for compliance for unvented (vent free) gas log sets.

WARNING: Do not operate a vented gas log set in this fireplace with the chimney removed.

8. Exterior Maintenance

Annually, at a minimum, check all metal flashings and weather seals around the exterior chimney where it penetrates the roof surface; inspect any chimney top spark arrestors, metal cowlings and weather hoods to make sure they are secure and weather tight.

Seal any cracks or gaps in chimney-to-roof flashings to prevent possible roof and chimney chase leaks.

Inspect any cement chimney cap or clay chimney pot terminations to make sure they are not diverting water into the structure. Seal any suspected cracks or gaps in these masonry components.

Registration Card

Please tear out along line and send to:

Earthcore Industries
Attn: Technical Department
6899 Phillips Industrial Blvd
Jacksonville, FL 32256

Dealer

Date of Purchase: _____ Date Of Installation: _____

Address: _____

City, State, Zip: _____

Phone No.: _____

Fireplace Model (Circle One): 80S36 80S42 80S46

Fuel Type (Circle One): Natural Gas Propane Solid Wood

Firebox Serial Number: _____
(Located on Rating Plate Inside Firebox)

Buyer: _____

Address: _____

City, State, Zip: _____

Phone No.: _____

Installed By: _____

Address: _____

City, State, Zip: _____

Phone No.: _____

Warranty & Disclaimer

Isokern STANDARD Series Fireplace

Earthcore offers a lifetime warranty for all Isokern components, to be free from defects in materials that negatively affect system performance from the date of purchase, subject to the terms and conditions of this limited warranty.

This warranty covers only the above stated components, and NO WARRANTY, EXPRESS OR IMPLIED, EXTENDS TO ANY OF THE HARDWARE, FOOTING, VENTS, DUCTING, METAL FLUES, FIREBRICK OR ACCESSORIES. THIS WARRANTY DOES NOT COVER DRAFTING, SMOKING OR PUFFING OF THE FIREPLACE SYSTEM. Factors beyond the manufacturer's control affect fireplace drafting, smoking, and puffing, and Earthcore cannot guarantee these aspects of performance.

If a component is found to be defective under the terms of this warranty the party to whom this warranty is extended shall, notify Earthcore, 6899 Philips Industrial Blvd, Jacksonville, Florida 32256, in writing, by registered mail, within thirty (30) days following the discovery of the defect within the lifetime warranty period. The notice shall contain (1) the date of purchase; (2) place of purchase; (3) address of installation; (4) name, address and phone number of the owner; and (5) a brief description of the defect.

Earthcore, or any division thereof, is not responsible for any labor costs or indirect costs incurred for the replacement of defective components.

Earthcore is not responsible for misuse or mishandling of components. Nothing in this warranty makes Earthcore, or any division thereof, liable in any respect for any injury or damage to the building or structure in which the fireplace or chimney system has been installed or to persons or property therein arising out of the use, misuse, or installation of properly manufactured ISOKERN product.

EARTHCORE, OR ANY DIVISION THEREOF, SHALL NOT BE HELD LIABLE FOR ANY INCIDENTAL OR CONSEQUENTIAL DAMAGES OR EXPENSES ARISING OUT OF THE USE OF THE FIREPLACES OR CHIMNEY SYSTEMS. ALL SUCH DAMAGES AND EXPENSES ARE HEREBY EXCLUDED.

This warranty is null and void when the fireplace or chimney systems are not installed pursuant to the installation instructions provided by Earthcore or local building codes have not been followed completely.

This warranty applies only to those fireplace and chimney systems installed in the continental United States, Alaska, and Canada. If any part of this warranty is found to be unenforceable, the remaining parts shall remain in force and effect.

EARTHCORE HEREBY DISCLAIMS ALL GUARANTEES AND WARRANTIES, EXPRESS OR IMPLIED, BEYOND THE WARRANTIES SET FORTH HEREIN.

earthcore[®]

6899 Phillips Industrial Blvd. • Jacksonville, FL 32256 • 904.363.3417 • f: 904.363.3408 • earthcore.com