

Isokern® MAXIMUS Linear Series Glass-Front Gas Fireplace and Chimney System with X-VENTISO-Meridian Max Linear Fan System

Installation, Operation, Maintenance and Owner's Manual

Isokern Models 82L48, 82L72, 82L96 & 82L120

with Glass Front Kits GFK-48, GFK-72, GFK-96 & GFK-120

A PRODUCT OF EARTHCORE® INDUSTRIES, LLC

IMPORTANT: This manual contains assembly rules, installation steps and guidelines, and use and maintenance instructions for Isokern MAXIMUS Linear Series with Glass Front Kit gas appliances with X-Ventiso-Meridian Max Linear Fan System. This manual must become the property of and be reviewed by all current and future users of this product. It is the responsibility of the distributor, general contractor, and the installer of this product that the instructions in this manual are followed exactly and, further that the allowed gas log appliance used in this product be installed in strict accordance with the gas log manufacturer's listing and explicit installation and operation instructions.

INSTALLER: Leave this manual with the appliance
CONSUMER: Retain this manual for future reference

Be Sure to Read Entire Manual Before Beginning Construction.

Contents of this manual may change without prior notification.



WARNING:

FIRE OR EXPLOSION HAZARD

Failure to follow safety warning exactly could result in serious injury, death, or property damage.

— Do not store or use gasoline or other flammable vapors and liquids in the vicinity of this or any other appliance.

— WHAT TO DO IF YOU SMELL GAS

- Do not try to light any appliance.
- Leave the building immediately.
- Do not touch any electrical switch; do not use any phone in your building.
- Immediately call your gas supplier from a neighbor's phone. Follow the gas supplier's instructions.
- If you cannot reach your gas supplier, call the fire department.

— Installation and service must be performed by a qualified installer, service agency or the gas supplier.

Do not install the Isokern MAXIMUS Linear Series Gas Fireplace in a manufactured home or mobile home or recreational vehicle.

- This appliance complies with National Safety and is tested and listed to ANSI/CSA Z21.50 – 2019 as vented gas fireplaces.
- Installation must conform to local codes. Check local codes prior to installation. In the absence of local codes, installation must conform with current National Fuel Gas Code, ANSI Z223.1.



PFS Report No. F19-161
USA: ANSI Z21.50 - 2019
ICC Report No. ESR – 4873

Issued: April 2024
Revision: 000
©2020 Earthcore Industries, LLC

**THESE FIREPLACES ARE DESIGNED FOR USE WITH:
PROPANE (LP) or NATURAL GAS (NG), ONLY
THIS MANUAL CAN ONLY BE REPRODUCED IN ITS ENTIRETY**

Table of Contents

<u>Table of Contents</u>	2	<u>X-VENTISO-Meridian 350 Fan and Adapter –</u>	
<u>General Information</u>	3	<u>General Information</u>	39
<u>Safety Instructions</u>	4	<u>X-VENTISO-Meridian Control Panel –Installation</u>	40
<u>Isokern Maximus Linear Series with</u>		<u>Selecting Horizontal or Vertical Venting System</u>	42
<u>Glass Front Kit 48” (82L48-GFK)</u>	6	<u>Vent Installation-General</u>	42
<u>Isokern Maximus Linear Series with</u>		<u>Vent Installation-Vertical Termination Systems</u>	43
<u>Glass Front Kit 72” (82L72-GFK)</u>	9	<u>Vent Installation-Horizontal Termination Systems</u>	45
<u>Isokern Maximus Linear Series with</u>		<u>Vent Installation-Stack Pressure and</u>	
<u>Glass Front Kit 96” (82L96-GFK)</u>	12	<u>Room Pressure Probe</u>	47
<u>Isokern Maximus Linear Series with</u>		<u>Firebrick Installation - General Information</u>	48
<u>Glass Front Kit 120” (82L120-GFK)</u>	15	<u>Flush Wall Finish Detail</u>	50
<u>Required Clearance to Combustible Framing</u>	18	<u>Clearance to Combustible Trim</u>	51
<u>Calculating Flooring Loads</u>	19	<u>Isoflames Linear Burner - Safety Instructions</u>	52
<u>Rough Framing Dimensions</u>	20	<u>Isoflames Linear Burner - Components List</u>	55
<u>General Assembly Instructions</u>	22	<u>Isoflames Linear Burner - Specifications</u>	56
<u>Isokern Maximus Linear Glass Front Installation</u>	23	<u>Gas Line & Valve Box Installation</u>	57
<u>Assembled Maximus Linear Glass Front Units</u>	30	<u>Valve Box & Burner Wiring Diagram</u>	58
<u>Access Modification</u>	32	<u>Burner Installation</u>	59
<u>B-Vent Metal Chimney - General Information</u>	33	<u>Remote Control System</u>	64
<u>B-Vent Metal Chimney and Components</u>	35	<u>Burner Lighting Instructions</u>	66
<u>General Venting Requirements</u>	35	<u>Full System Initialization</u>	67
<u>X-VENTISO-Meridian Max Linear Fan System -</u>		<u>Glass Panel Installation</u>	68
<u>General Information</u>	36	<u>Troubleshooting</u>	69
<u>X-VENTISO-Meridian Max Linear Fan System -</u>		<u>Glass Media Options</u>	71
<u>Components</u>	37	<u>Appendix A: X-VENTISO Meridian Max</u>	
<u>X-VENTISO-Meridian Control Panel –</u>		<u>Linear Fan System: Connection Diagram</u>	72
<u>General Information</u>	37	<u>Registration Card</u>	75
<u>X-VENTISO-Meridian Damper –General Information</u>	38	<u>Warranty</u>	76



ISOKERN LINEAR GAS FIREPLACE
LISTED VENTED GAS FIREPLACE PER ANSI Z21.50 - 2019
CSA 2.22-2019



NOT FOR USE WITH SOLID FUEL

PFS REPORT NO. F19 - 161

SERIAL NO: L000001

MODEL # 82L48 82L72
82L96 82L120

FOR USE WITH PROPANE (LP) OR NATURAL GAS, SEE GAS IDENTIFYING TAG ON BURNER

82L48 NATURAL GAS MAX BTU 54,000; PROPANE MAX BTU 48,000
 82L72 NATURAL GAS MAX BTU 90,000; PROPANE MAX BTU 80,000
 82L96 NATURAL GAS MAX BTU 108,000; PROPANE MAX BTU 96,000
 82L120 NATURAL GAS MAX BTU 110,000; PROPANE MAX BTU 105,000

*See Burner Rating Plate For Additional Information
 MANIFOLD PRESSURE: PROPANE (LP): 10" WATER COLUMN; NATURAL GAS: 3.5" WATER COLUMN
 MINIMUM PERMISSIBLE GAS SUPPLY PRESSURE FOR PURPOSE OF INPUT ADJUSTMENT:
 PROPANE (LP): 11" WATER COLUMN; NATURAL GAS: 5" WATER COLUMN

ELECTRICAL RATING:	CLEARANCE TO COMBUSTIBLES:	Open Front Only	Glass Front Only
UNIT: ELECTRONIC	SMOKE DOME FRONT	= 0in.	= 0in.
1 PH	UNIT SIDES AND REAR	= 1.5in.	= 1.5in.
60 HZ	COMBUSTIBLE SHEATHING ABOVE OPENING	= 8in.	= 0in.
120 VOLTS	TOP SHEATHING OR TRIM TO OPENING SIDES	= 8in.	= 0in.
LESS THAN 5 AMPS	MANTEL ABOVE OPENING	= 12in.	= 0in.
	INSULATION FROM FIREBOX	= 3in.	= 3in.

CAUTION: THIS APPLIANCE IS ONLY FOR USE WITH THE TYPE OF GAS INDICATED ON THE RATING PLATE. THIS APPLIANCE IS NOT CONVERTIBLE FOR USE WITH OTHER GASES, UNLESS A CERTIFIED KIT IS USED.

This appliance must be installed in accordance with local codes, if any, if none, follow the current ANSI Z223.1/NFPA 54 or CSA B149.1
See Installation and Operating Instructions for this model and ICC # ESR - 4873

EARTHCORE INDUSTRIES HEADQUARTERS
JACKSONVILLE, FL 32256

The latest revision of this manual may be obtained at the Earthcore website:

<https://www.earthcore.com/installation-manuals/>

OR

Scan this QR code



General Information

Isokern Maximus Linear Series Models 82L48-GFK, 82L72-GFK, 82L96-GFK and 82L120-GFK are tested and listed by PFS Corp., USA Report No. F19-161 to ANSI Z21.50 - 2019 and Canadian Standard CSA 2.22 - 2019. The Isokern Maximus Linear Series fireplaces are top-vented, gas only fireplaces that are listed for use only with the Isoflames Linear Burner gas appliance listed in this installation manual. These gas appliances come with a gas control valve that includes an automatic shut-off switch. The gas valve is available in a millivolt remote control pilot assembly.

The exhaust flue gases are to be vented through the top of the unit with listed B-Vent piping. A twelve-inch (12”) diameter, double wall B-Venting system is required and will utilize the X-VENTISO-Meridian Max Linear Fan System as detailed in this manual. The Meridian Max Linear Fan system is required for proper operation of all Isokern Maximus Linear models 48, 72, 96 and 120.

WARNING!!!: This gas appliance must not be connected to a chimney flue servicing a solid fuel burning appliance.

INTENDED USE STATEMENT

The Isokern Maximus Linear Series with Glass-Front is intended to burn propane (LP) gas or natural gas (NG), only. This appliance is not intended to be used as a primary source of heat.

The Isokern Maximus Linear Series with Glass Front and its approved components are safe when installed according to this installation manual and when operated as recommended by the manufacturer. Unless you use Earthcore Industries, LLC approved components tested for this appliance, you may cause a fire hazard or serious injury. Before you begin the installation of this appliance, read these instructions completely.

Earthcore Industries, LLC disclaims any responsibility for the following actions:

- Modification of the appliance or any of its components.
- Use of any component part not approved by Earthcore Industries in combination with this appliance.
- Installation or operation in a manner other than instructed in this manual.
- Burning of anything (solid fuel) other than the listed gas log unit and the type of gas approved for use in this gas appliance.

The most important areas of concern with the installation of the Isokern Maximus Linear Series with Glass Front are clearance to combustible materials, proper assembly of component parts, load carrying capacity of underlying floor system, heights of chimney system, hearth extensions, and the techniques employed in applying finishing materials to the walls surrounding the Isokern Maximus Linear Series with Glass Front.

IMPORTANT: Cooling air kits are required for operation of the Maximus Linear with Glass-Front fireplaces.

Each of these topics will be covered in detail throughout this manual. Special attention must be given to each topic as the installation progresses.

The installation of the Isokern Maximus Linear Series with Glass Front must conform with local codes or, in the absence of local codes, with the current National Fuel Gas Code, ANSI-Z223.1/NFPA 54 or the current Natural Gas and Propane Installation Code, CSA B149.1.

SEISMIC CODE SPECIFICATIONS

If installation of the Isokern Firebox is to be installed in an area with seismic codes please follow these instructions. Four #4 ASTM A615 Grade 40 minimum, vertical reinforcing bars, 2 on each side of the firebox running from top of sidewalls to approximately 4 inches into the concrete slab (for anchorage).

Important: The top plate of the firebox shall not to be used as a structural support. The top plate is not designed to be a weight / load bearing surface.

Note: Do not scale drawings. Illustrations in this manual are not to scale and are intended to show “typical” installations. Nominal dimensions are given for design and framing reference only. Actual installations may vary due to job specific design preferences. Always maintain the stated minimum clearances to combustible materials. Do not violate any specific installation requirements.

Safety Instructions

WARNING!!! This product contains or generates chemicals known to the state of California to cause cancer or birth defects or other reproductive harm.

IMPORTANT: Read this owner's manual carefully and completely before trying to assemble, operate, or service this fireplace. Improper use of this fireplace can cause serious injury or death from fire, burns, explosions, or carbon monoxide poisoning.

DANGER: CARBON MONOXIDE POISONING MAY LEAD TO DEATH!

This fireplace is a vented product and will not produce any gas leakage into your home if properly installed by a qualified service person. If this unit is not properly installed by a qualified service person, gas leakage may occur. Propane (LP) gas and natural gas (NG) are both colorless and odorless gases. An odor-making agent is added to each of these gases to help you detect a gas leak. However, the odor added to these gases can fade and gas may be present even though no odor exists.

CARBON MONOXIDE POISONING: Early signs of carbon monoxide poisoning resemble flu symptoms, including headaches, dizziness, or nausea. If you have these signs the fireplace may not have been installed properly, get fresh air at once! Have the fireplace inspected and serviced by a qualified service person or your gas supplier. Some people are more affected by carbon monoxide than others. These include pregnant women, people with heart or lung diseases or anemia, people at high altitude or under the influence of alcohol. Earthcore Industries strongly recommends the use of a carbon monoxide detector/alarm device wherever gas fired appliances are in use.

All parties either involved in or associated with the installation, service and use of this fireplace must read this entire manual. Keep this manual for reference and as a guidebook to safe operation of this fireplace.

WARNING!!! This unit is not for use with solid fuel.

- 1) Always check local building codes governing fireplaces and fireplace installations. The Isokern Maximus Linear Series installation must comply with all local, regional, state, and national codes and regulations.
- 2) The Isokern Maximus Linear Series fireplaces are listed for use with the specific venting and burner system as detailed in this manual only.
- 3) This appliance is only for use with the type of gas indicated on the rating plate. This appliance can be field converted for use with either Propane (LP) or Natural Gas (NG). Contact your local Isokern Sales Representative for details.
- 4) For propane (LP) use do not place propane supply tank(s) inside any structure. Locate propane supply tank(s) outdoors. To prevent performance problems, do not use propane fuel tank of less than 100 lbs. capacity.
- 5) Do not install the Isokern Maximus Linear Series Gas Fireplace in a manufactured home or mobile home or recreational vehicle.
- 6) This fireplace reaches high temperature. Keep children and adults away from hot surfaces to avoid burns or clothing ignition. Fireplace will remain hot for a time after shutdown. Allow surfaces to cool before touching.
- 7) Turn the Isokern Maximus Linear Series fireplace off and allow to cool before servicing. Always shut off any electricity and gas to the Isokern Maximus Linear Series fireplace while working on it. Only a qualified service person should install, service, or repair this fireplace. Have your fireplace inspected annually by a qualified service person.
- 8) It is imperative that the unit's control areas, burners, and circulation air passages be kept clean.
- 9) Venting system should be inspected annually by a qualified service person. If needed have venting system cleaned or repaired.
- 10) Keep all combustible material, gasoline, and other flammable liquids at a safe distance from the fireplace. Do not use the fireplace where these items are used or stored. Decorations, clothing, and other such combustible items should not be placed on the fireplace.

Safety Instructions

- 11) Do not use the Isokern Maximus Linear Series fireplace to cook food or burn paper or other objects.
- 12) Do not use any solid fuels - wood, coal, paper, cardboard, etc. - in this fireplace. Use only the gas type listed on the fireplace's burner rating plate.
- 13) Keep all unshielded insulation and vapor barriers a minimum of three inches (3") away from all Isokern Maximus Linear Series and chimney components.
- 14) Do not pack or fill required air spaces with insulation or other material. No material is allowed in these spaces.
- 15) Never install Isokern Maximus Linear Series components, chimney components, or accessories that have visible or suspected physical damage due to handling or transportation. These items should be inspected by a qualified representative to ensure safe condition. When in doubt, consult your local supplier.
- 16) Do not alter or modify the Isokern Maximus Linear Series and/or venting components under any circumstances. Modification or alteration of the venting components may void manufacturer's warranty, listings, and approvals.
- 17) Do not use a fireplace blower insert, heat exchanger or any other product not specified by the manufacturer herein for use with this fireplace.
- 18) Do not use any Isokern Maximus Linear Series appliance if any part has been under water. Immediately call a qualified service technician to inspect the appliance and to replace any part of the control system and any gas control which has been under water.
- 19) The Isokern Maximus Linear Series is not intended to heat an entire home or to be used as a primary heat source.
- 20) Children and adults should be alerted to the hazards of high surface temperature and should stay away from this appliance to avoid burns or clothing ignition.
- 21) Young children should be carefully supervised when they are in the same room as the appliance. Toddlers, young children, and others may be susceptible to accidental contact burns. A physical barrier is recommended if there are at-risk individuals in the house. To restrict access to the fireplace, install an adjustable safety gate to keep toddlers, young children, and other at-risk individuals out of the room and away from hot surfaces.
- 22) Clothing or flammable material should not be placed on or near the appliance.
- 23) Due to high temperatures, the appliance should be located out of traffic and away from furniture and draperies.
- 24) Installation and repair should be done by a qualified service person. The appliance should be inspected before use and at least annually by a professional service person. More frequent cleaning may be required due to excessive lint from carpeting, bedding material, etcetera. It is imperative that control compartments, burners, and circulating air passageways of the appliance be kept clean.
- 25) **Do not nail or screw any material into the Isokern fireplace, which includes firebox or smoke dome components unless specifically instructed in this manual. This may alter the integrity of the fireplace and cause a house fire. THIS WILL VOID THE WARRANTY OF THE FIREPLACE.**
- 26) Never spray or apply any type of sealer, insulation, or other materials to the fireplace
- 27) The Maximus Linear with Glass Front shall not be operated without the glass panels installed.
- 28) DO NOT clean glass front when hot or when in use. Wait until appliance is OFF and has cooled to room temperature before cleaning glass. Do not use abrasive cleaners on the glass

Isokern Maximus Linear Series with Glass Front Kit 48" (82L48-GFK)

You will need to order the 82L48 and GFK-48 to build the complete Glass Front Fireplace

Requires X-VENTISO-Meridian Max Linear Fan System for proper operation

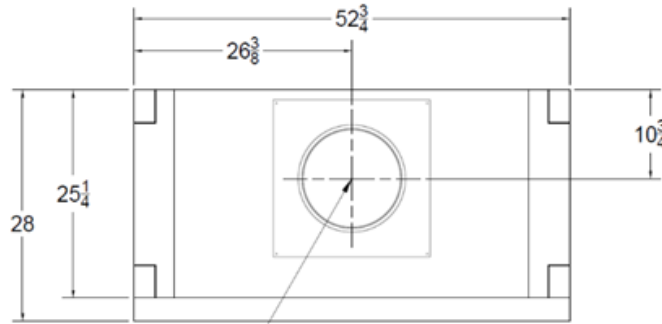

METAL-FAB 12" B-VENT PIPE (12" I.D./13" O.D.) W/
 DOWN-DRAFT DIVERTER; X-VENTISO-MERIDIAN MAX
 LINEAR FAN SYSTEM REQUIRED.

Top View

FRAME OPENINGS TO 15" X 15" CLEAR TO MAINTAIN
 MIN. 1" CLEARANCE TO COMBUSTIBLES.

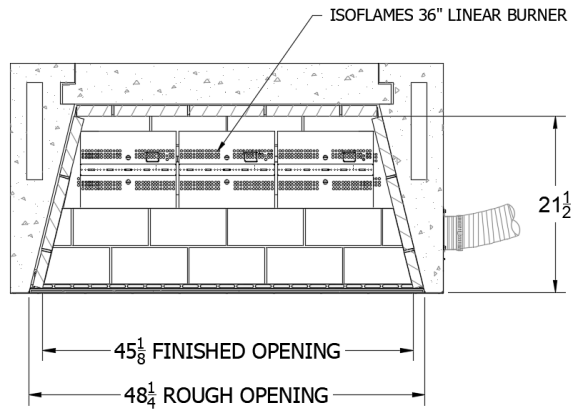

Plan View

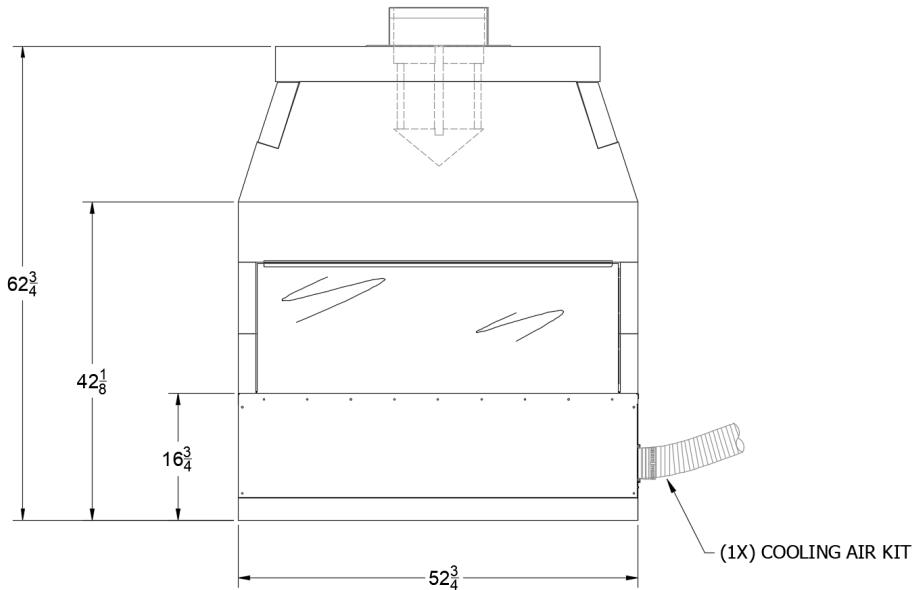

Front View

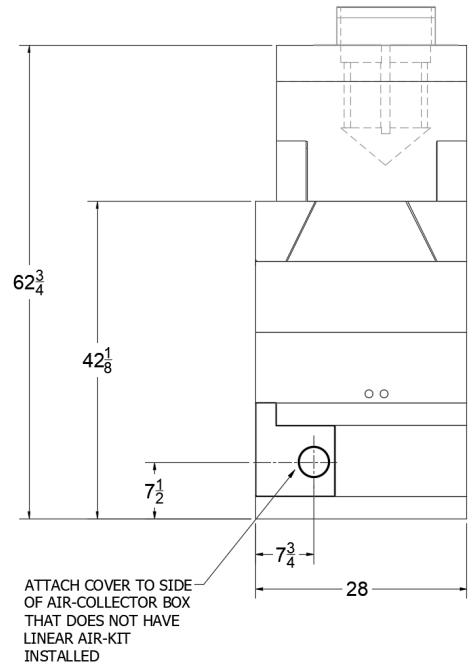

Side View

Isokern Maximus Linear Series 48” Components (82L48)

You will need to order the 82L48 and GFK-48 to build the complete Glass Front Fireplace

Requires X-VENTISO-Meridian Max Linear Fan System for proper operation

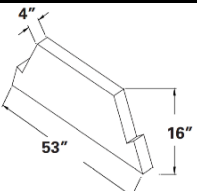
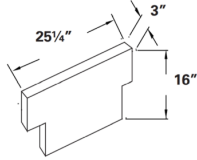
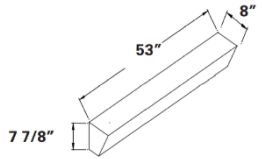
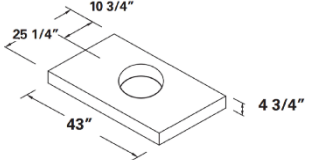

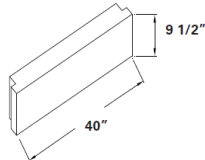
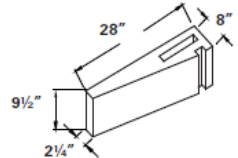
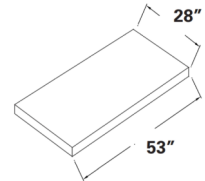
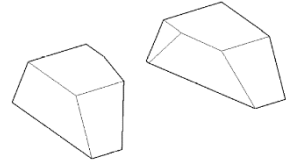
<u>Component</u>	<u>Part#</u>	<u>Description</u>
	13	Smoke Dome-48 (Qty: 2)
	34	Smoke Dome Side Wall (Qty: 2)
	70	Damper Beam-48 (Qty: 2)
	81	Top Plate-46/48 (Qty: 1)

<u>Component</u>	<u>Part#</u>	<u>Description</u>
	M67	Backwall (Qty: 2)
	M90	Magnum Sidewall (Qty: 4)
	M93	Magnum Base Plate-48 (Qty: 1)
	M94L & M94R	Magnum Damper End Block; Left and Right

Isokern Maximus Linear Series Glass Front Kit 48” (GFK-48)

You will need to order the 82L48 and GFK-48 to build the complete Glass Front Fireplace

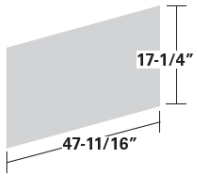
Requires X-VENTISO-Meridian Max Linear Fan System for proper operation

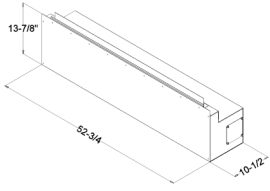
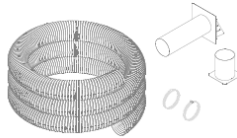
Component	Part#	Description
	CG1	Glass Panels (Qty: 1)
	E-TG1	Top Glass Bracket B (Qty: 1)
	E-ACB-B	Air Collector Box Assembly B (Qty: 1)
	OAK12NG	Isokern Linear Air Kit (Qty: 1)

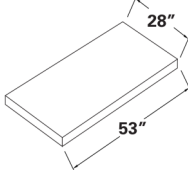
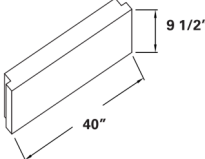
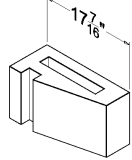
Component	Part#	Description
	23	GFK Base Plate 23 (Qty: 1)
	M67	Isokern Linear Backwall (Qty: 1)
	M90B	GFK Side Wall (Qty: 2)

Isokern Maximus Linear Series with Glass Front Kit 72” (82L72-GFK)

You will need to order the 82L72 and GFK-72 to build the complete Glass Front Fireplace

Requires X-VENTISO-Meridian Max Linear Fan System for proper operation

Steel angle: 6” x 6” x 1/2” cut to span firebox opening. This item is not included in the components and can be sourced locally

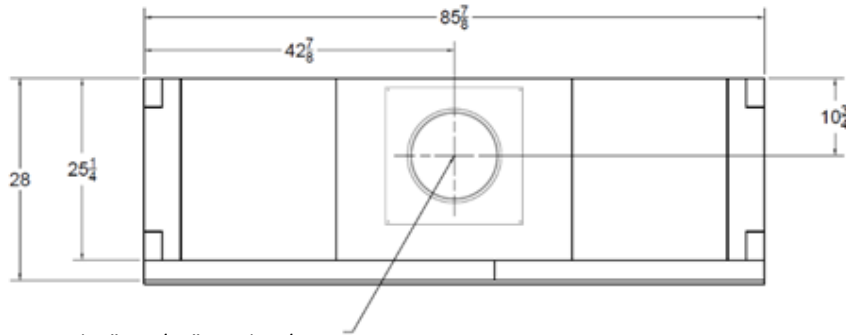

METAL-FAB 12" B-VENT PIPE (12" I.D./13" O.D.) W/
DOWN-DRAFT DIVERTER; X-VENTISO-MERIDIAN MAX
LINEAR FAN SYSTEM REQUIRED.

FRAME OPENINGS TO 15" X 15" CLEAR TO MAINTAIN
MIN. 1" CLEARANCE TO COMBUSTIBLES.

Top View

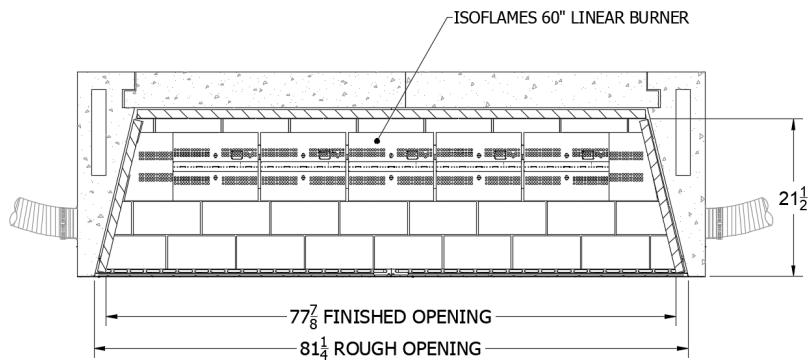

Plan View

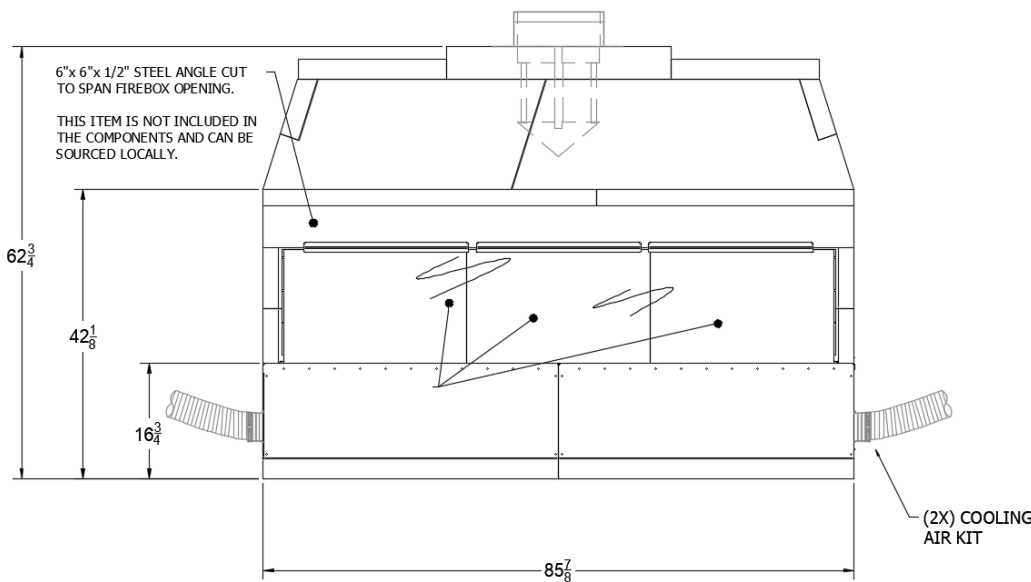

Front View

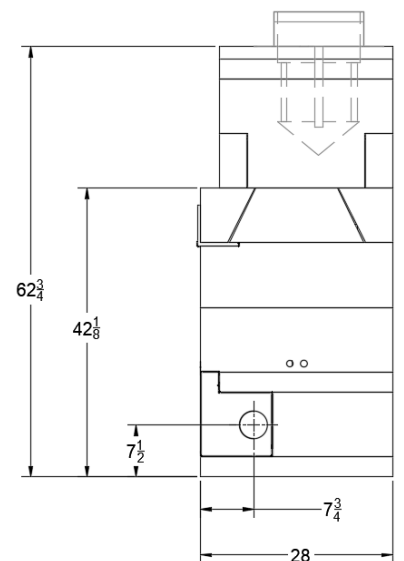

Side View

Isokern Maximus Linear Series 72” Components (82L72)

You will need to order the 82L72 and GFK-72 to build the complete Glass Front Fireplace

Requires X-VENTISO-Meridian Max Linear Fan System for proper operation

Steel angle: 6” x 6” x 1/2” cut to span firebox opening. This item is not included in the components and can be sourced locally

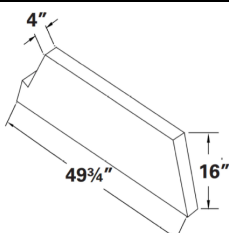
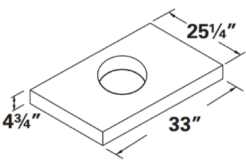
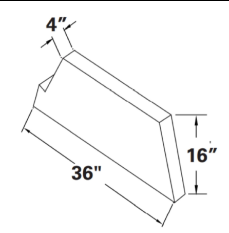
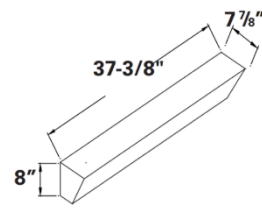
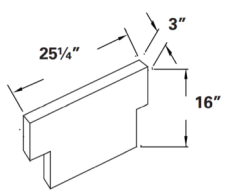
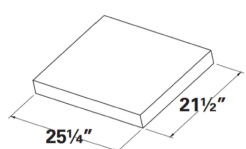
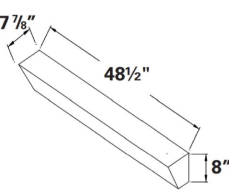
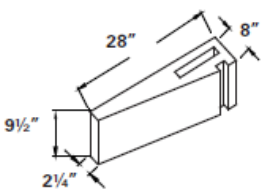
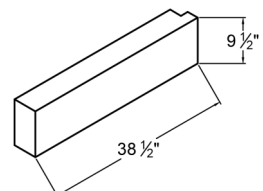
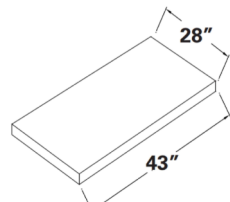
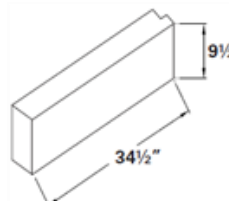
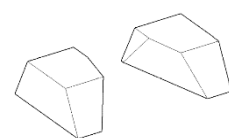
Component	Part#	Description	Component	Part#	Description
	16	Smoke Dome-60/72 (Qty: 2)		77A	Top Plate-36/42 (Qty: 1)
	18	Smoke Dome-72 (Qty: 2)		83	Damper Beam-72 (Qty: 2)
	34	Smoke Dome Side Wall (Qty: 2)		121	Top Plate-82L72 (Qty: 2)
	69	Damper Beam-42 (Qty: 2)		M90	Magnum Sidewall (Qty: 4)
	72	Backwall-60/72 (Qty: 2)		M91	Magnum Base Plate-36 (Qty: 2)
	73	Backwall-72 (Qty: 2)		M94L & M94R	Magnum Damper End Block; Left and Right (Qty: 1 Each)

Isokern Maximus Linear Series Glass Front Kit 72” (GFK-72)

You will need to order the 82L72 and GFK-72 to build the complete Glass Front Fireplace

Requires X-VENTISO-Meridian Max Linear Fan System for proper operation

Steel angle: 6” x 6” x 1/2” cut to span firebox opening. This item is not included in the components and can be sourced locally

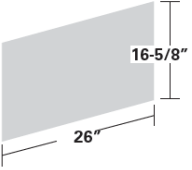
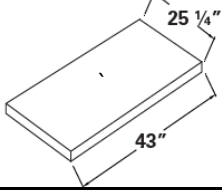
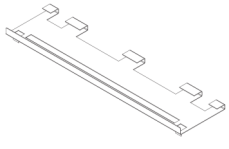
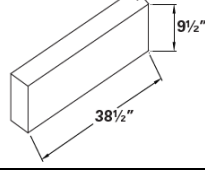
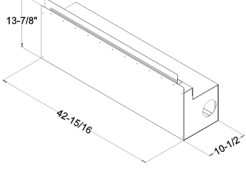
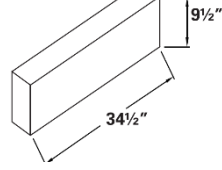
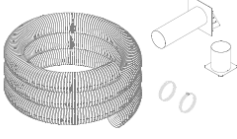
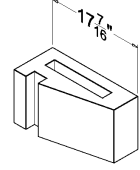
Component	Part#	Description	Component	Part#	Description
	CG2	Glass Panels (Qty: 1) Note: the CG2 contains 3 Panels		21	GFK Base Plate 21 (Qty: 2)
	E-TG2	Top Glass Bracket B (Qty: 3)		72	Isokern Linear Backwall (Qty: 1)
	E-ACB-A	Air Collector Box Assembly A (Qty: 2)		73	Isokern Linear Backwall (Qty: 1)
	OAK12NG	Isokern Linear Air Kit (Qty: 2)		M90B	GFK Side Wall (Qty: 2)

Isokern Maximus Linear Series with Glass Front Kit 96” (82L96-GFK)

You will need to order the 82L96 and GFK-96 to build the complete Glass Front Fireplace

Requires X-VENTISO-Meridian Max Linear Fan System for proper operation

Steel angle: 6” x 6” x 1/2” cut to span firebox opening. This item is not included in the components and can be sourced locally

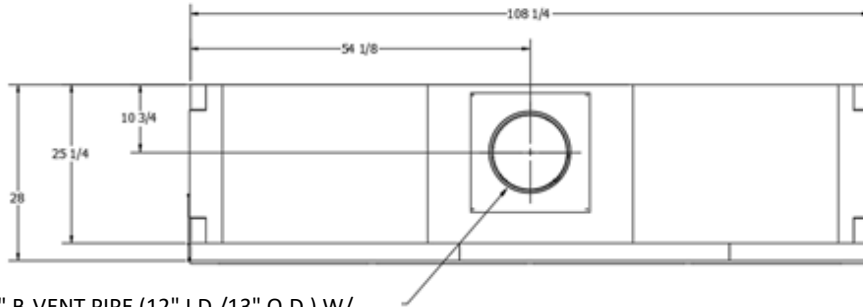

Top View

METAL-FAB 12” B-VENT PIPE (12” I.D./13” O.D.) W/
 DOWN-DRAFT DIVERTER; X-VENTISO-MERIDIAN MAX
 LINEAR FAN SYSTEM REQUIRED.

FRAME OPENINGS TO 15” X 15” CLEAR TO MAINTAIN
 MIN. 1” CLEARANCE TO COMBUSTIBLES.

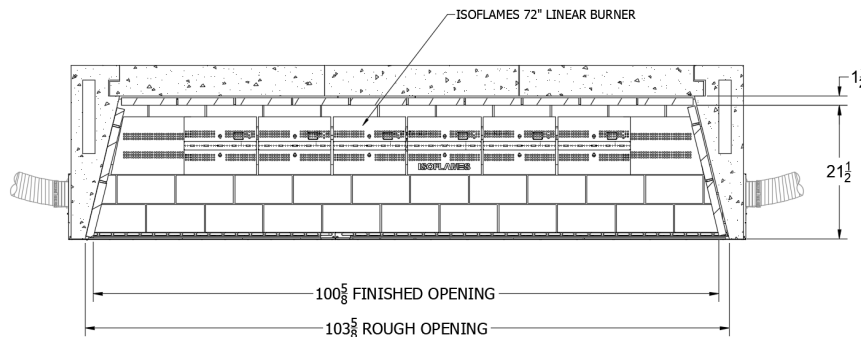

Plan View

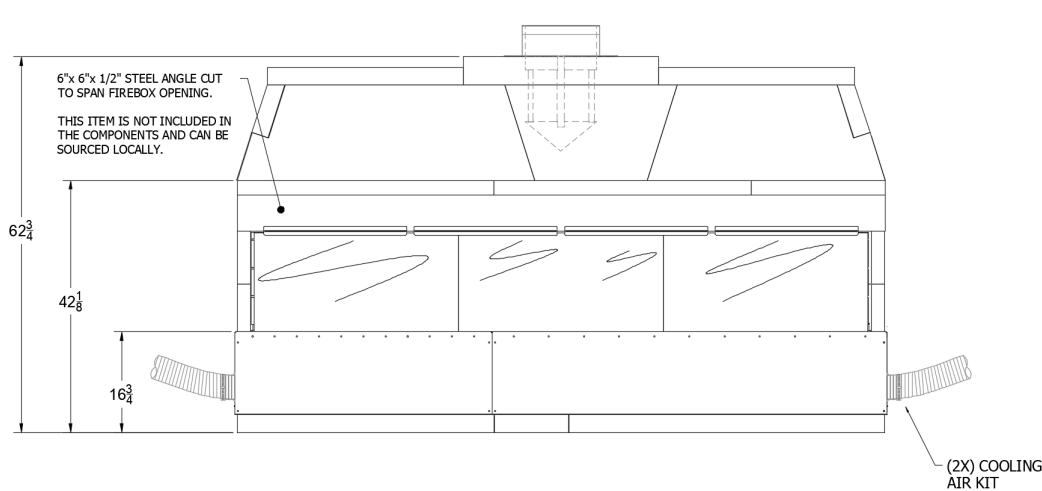

Front View

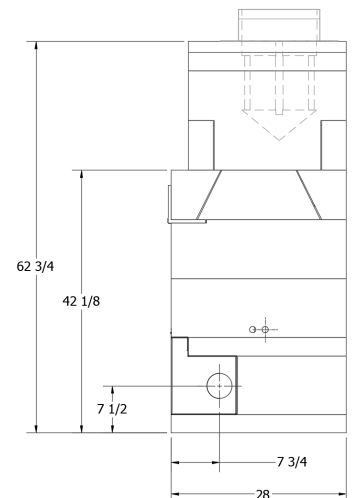

Side View

Isokern Maximus Linear Series 96" Components (82L96)

You will need to order the 82L96 and GFK-96 to build the complete Glass Front Fireplace

Requires X-VENTISO-Meridian Max Linear Fan System for proper operation

Steel angle: 6" x 6" x 1/2" cut to span firebox opening. This item is not included in the components and can be sourced locally

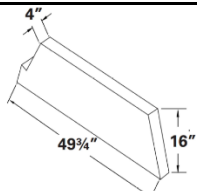
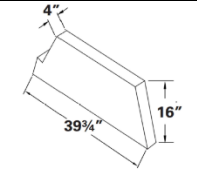
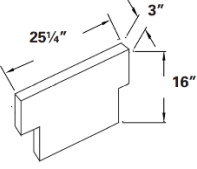
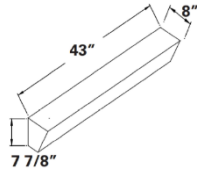
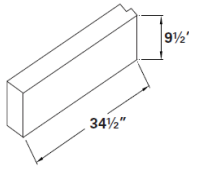
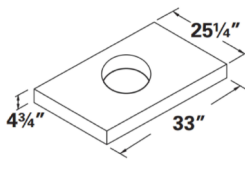
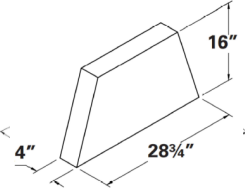
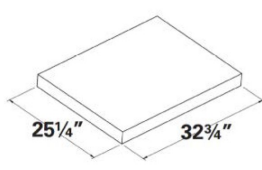
Component	Part#	Description
	16	Smoke Dome-60/72 (Qty: 2)
	17	Smoke Dome-60 (Qty: 2)
	34	Smoke Dome Side Wall (Qty: 2)
	68	Damper Beam-36 (Qty: 4)
	73	Backwall-72 (Qty: 2)
	77A	Top Plate-36/42 (Qty: 1)
	113	Smoke Dome-96 (Qty: 2)
	122	Top Plate-82L96 (Qty: 2)

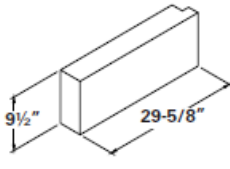
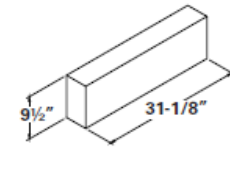
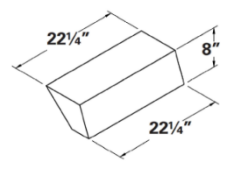
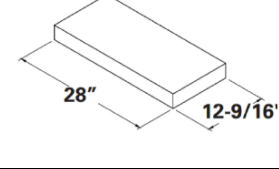
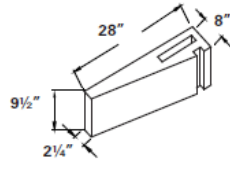
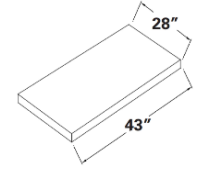
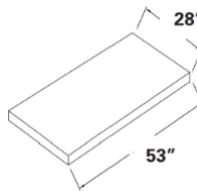
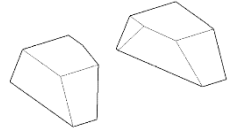
Component	Part#	Description
	160	Maximus 96 Backwall (Qty: 2)
	162	Maximus Backwall (Qty: 2)
	167	Damper Beam-96 (Qty: 2)
	191	Base Plate-84/96/108 (Qty: 1)
	M90	Magnum Sidewall (Qty: 4)
	M91	Magnum Base Plate-36 (Qty: 1)
	M93	Magnum Base Plate-48 (Qty: 1)
	M94L & M94R	Magnum Damper End Block; Left and Right

Isokern Maximus Linear Series Glass Front Kit 96” (GFK-96)

You will need to order the 82L96 and GFK-96 to build the complete Glass Front Fireplace

Requires X-VENTISO-Meridian Max Linear Fan System for proper operation

Steel angle: 6” x 6” x 1/2” cut to span firebox opening. This item is not included in the components and can be sourced locally

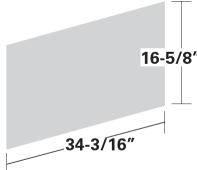
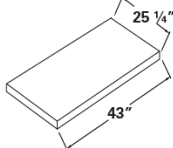
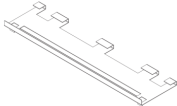
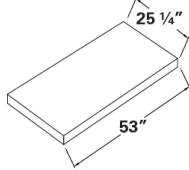
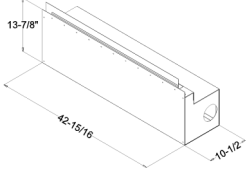
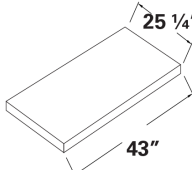
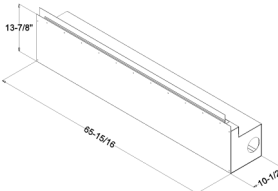
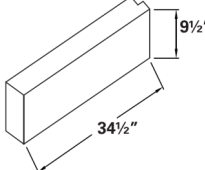
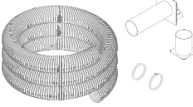
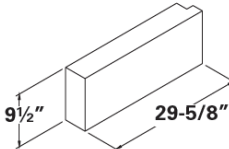
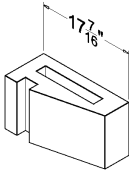
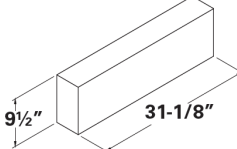
Component	Part#	Description	Component	Part#	Description
	CG3	Glass Panels (Qty: 1) Note: Each CG3 contains 3 Panels		21	GFK Base Plate 21 (Qty: 1)
	E-TG2	Top Glass Bracket B (Qty: 4)		23	GFK Base Plate 23 (Qty: 1)
	E-ACB-A	Air Collector Box A (Qty: 1)		124	GFK Base Plate 124 (Qty: 1)
	E-ACB-C	Air Collector Box C (Qty: 1)		73	Isokern Linear Backwall (Qty: 1)
	OAK12NG	Isokern Linear Air Kit (Qty: 2)		160	Isokern Linear Backwall (Qty: 1)
	M90B	GFK Side Wall (Qty: 2)		162	Isokern Linear Backwall (Qty: 1)

Isokern Maximus Linear Series with Glass Front Kit 120" (82L120-GFK)

You will need to order the 82L120 and GFK-120 to build the complete Glass Front Fireplace

Requires X-VENTISO-Meridian Max Linear Fan System for proper operation

Steel angle: 6" x 6" x 1/2" cut to span firebox opening. This item is not included in the components and can be sourced locally

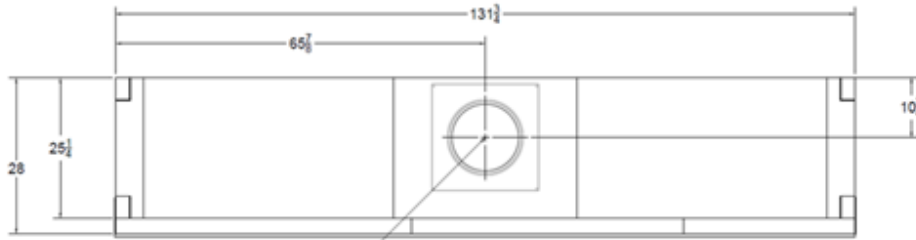

METAL-FAB 12" B-VENT PIPE (12" I.D./13" O.D.) W/
DOWN-DRAFT DIVERTER; X-VENTISO-MERIDIAN MAX
LINEAR FAN SYSTEM REQUIRED.

FRAME OPENINGS TO 15" X 15" CLEAR TO MAINTAIN
MIN. 1" CLEARANCE TO COMBUSTIBLES.

Top View

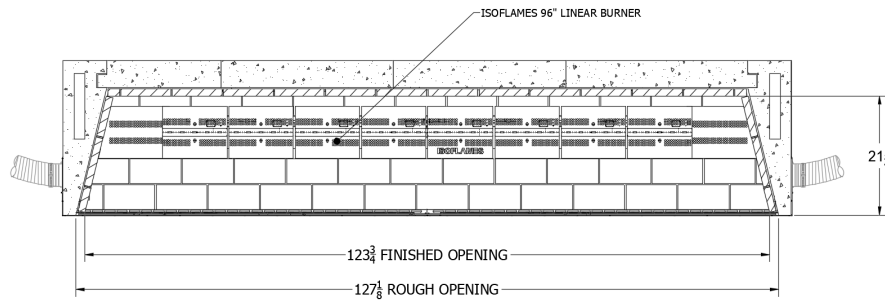

Plan View

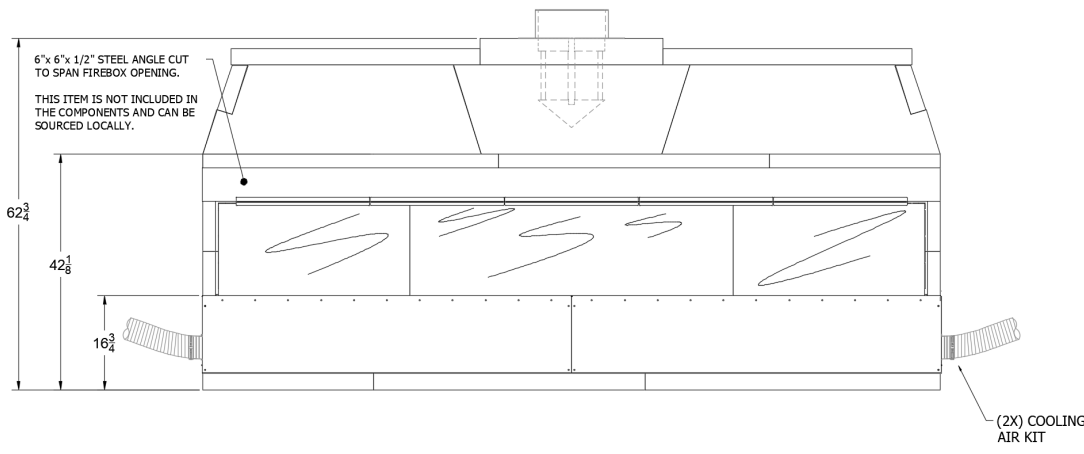

Front View

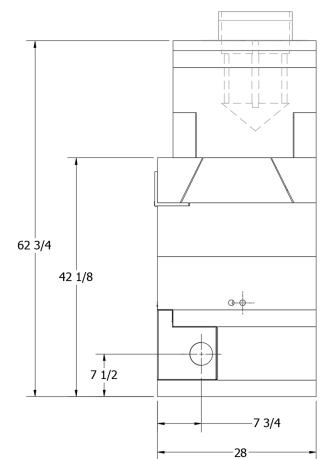

Side View

Isokern Maximus Linear Series 120” Components (82L120)

You will need to order the 82L120 and GFK-120 to build the complete Glass Front Fireplace

Requires X-VENTISO-Meridian Max Linear Fan System for proper operation

Steel angle: 6” x 6” x 1/2” cut to span firebox opening. This item is not included in the components and can be sourced locally

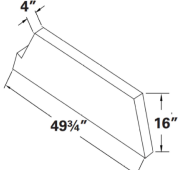
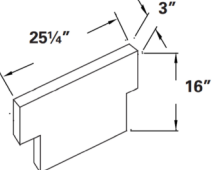
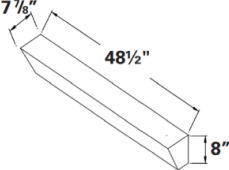
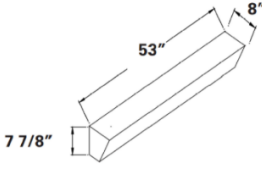
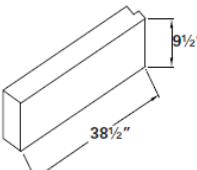
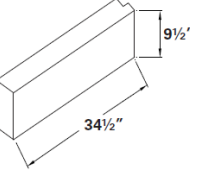
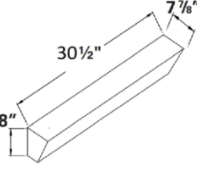
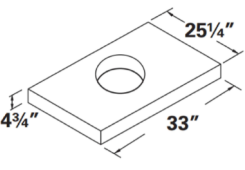
Component	Part#	Description
	16	Smoke Dome-60/72 (Qty: 4)
	34	Smoke Dome Side Wall (Qty: 2)
	69	Damper Beam -42 (Qty: 2)
	70	Damper Beam -46/48 (Qty: 2)
	71	Backwall 60/72 (Qty: 2)
	73	Backwall-72 (Qty: 2)
	74	Damper Beam -60 (Qty: 2)
	77A	Top Plate-36/42 (Qty: 1)

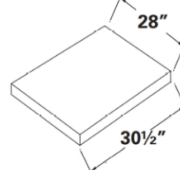
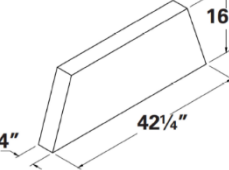
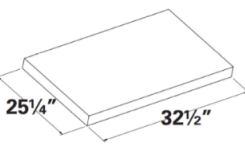
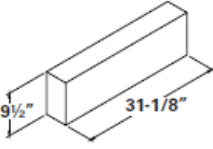
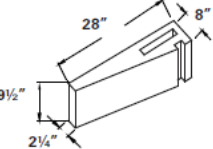
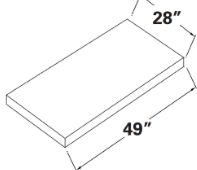
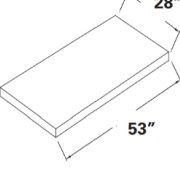
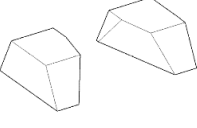
Component	Part#	Description
	96	Magnum Base Plate-60 (Qty: 1)
	116	Smoke Dome-120 (Qty: 2)
	123	Top Plate-82L120 (Qty: 2)
	162	Maximus Backwall (Qty: 4)
	M90	Magnum Sidewall (Qty: 4)
	M92	Magnum Base Plate-42 (Qty: 1)
	M93	Magnum Base Plate-48 (Qty: 1)
	M94L & M94R	Magnum Damper End Block; Left and Right (Qty: 1 Each)

Isokern Maximus Linear Series Glass Front Kit 120” (GFK-120)

You will need to order the 82L120 and GFK-120 to build the complete Glass Front Fireplace

Requires X-VENTISO-Meridian Max Linear Fan System for proper operation

Steel angle: 6” x 6” x 1/2” cut to span firebox opening. This item is not included in the components and can be sourced locally

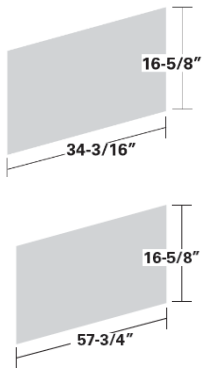
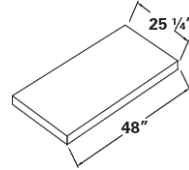
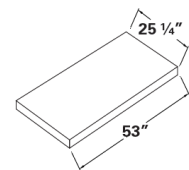
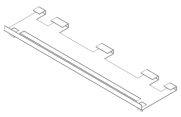
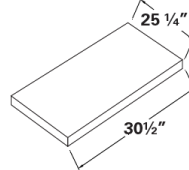
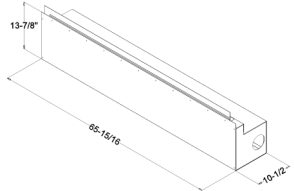
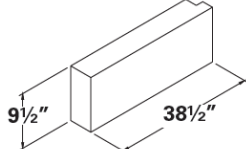
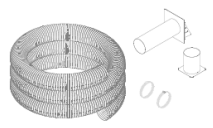
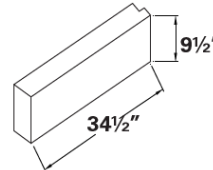
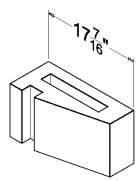
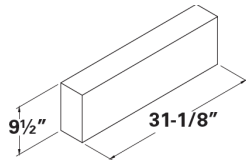
Component	Part#	Description	Component	Part#	Description
	CG4	Glass Panels (Qty: 1) Note: Each CG4 contains 3 panels (1 large, 2 Small) (Large Panel) 57-3/4"x16-5/8" (Small Panel) 34-3/16"x16-5/8"		22	GFK Base Plate 22 (Qty: 1)
				23	GFK Base Plate 23 (Qty: 1)
	E-TG2	Top Glass Bracket B (Qty: 5)		125	GFK Base Plate 125 (Qty: 1)
	E-ACB-C	Air Collector Box C (Qty: 2)		71	Isokern Linear Backwall (Qty: 1)
	OAK12NG	Isokern Linear Air Kit (Qty: 2)		73	Isokern Linear Backwall (Qty: 1)
	M90B	GFK Side Wall (Qty: 2)		162	Isokern Linear Backwall (Qty: 1)

Required Clearance to Combustible Framing

IMPORTANT: “Combustibles” are defined as “normal construction materials” such as: wood framing materials, particle board, mill board, plywood paneling, plywood sub-flooring and wood flooring.

The Maximus Linear Series with Glass Front fireplaces and chimney systems are tested and listed for installation with “clearance to combustibles” as follows:

- Zero-inch (0”) clearance to the combustible floor; (Isokern Base Plate must be used)
- Zero-inch (0”) clearance at the Isokern firebox front, smoke dome front.
- One- and one-half inches (1-1/2”) clearance at the sides of the Isokern firebox and smoke dome sides.
- One-inch (1”) minimum air space to combustibles at all B-Vent double wall chimney components’ outer layer.

WARNING!!!: When installing directly on carpet, tile, or other combustible material other than wood flooring, the appliance should be installed on a metal or wood panel extending the full width and depth of the appliance.

CAUTION: Maintain three inches (3”) clearance to insulation and vapor barriers from all firebox, smoke dome, and B-Vent flue components.

EXCEPTION: If insulation is used in walls surrounding the fireplace, insulation may be installed behind sheathing of gypsum board, plywood, particle board, or other rigid fire rated material on the side facing the Isokern. The facing material cannot be within 1-1/2” to the fireplace sidewalls.

NOTES:

- 1) The fireplaces must sit upon a support designed to bear the total installed weight of the fireplace.
- 2) All Maximus Linear installations with Glass Front will result in the minimum finished fire brick floor of the firebox being at least eighteen inches (18”) above the combustible floor system. **Never place a Maximus Linear on a combustible floor without the base plate!!!**

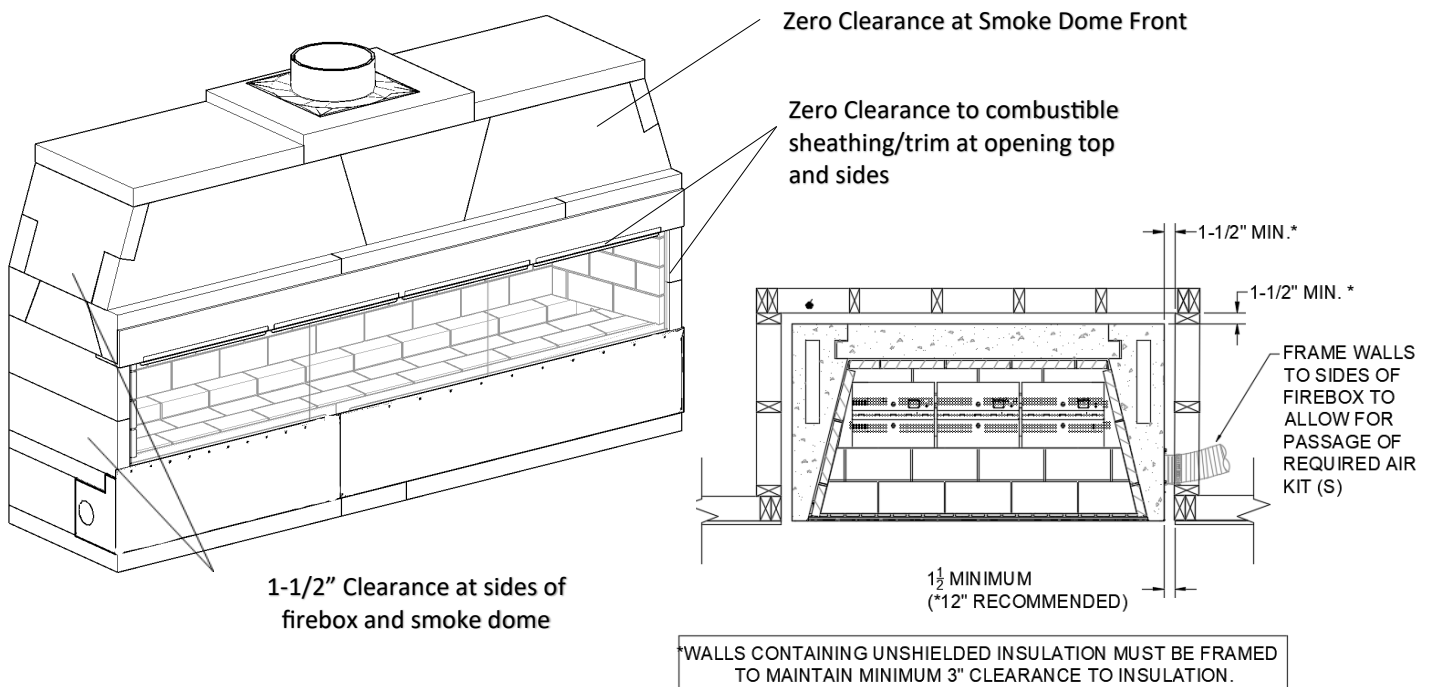

FIGURE 1

FIGURE 2

Calculating Flooring Loads

Floor framing for Maximus Linear installation will need to be designed and built to accept substantial dead loads spread over a relatively small floor area. **(Figure 3).**

The following weights and sizes can be used to calculate loading. It is the contractor's responsibility to provide adequate floor system load capacity.

WEIGHTS AND LOAD CALCULATIONS

Total dead load amounts include (but are not necessarily limited to) the following items and their corresponding weight estimates as listed below:

- 1) Isokern unit weights:
 - a. Maximus Linear w/ Glass Front - 48: 1,652 lbs. (no burner, flue, accessories)
 - b. Maximus Linear w/ Glass Front - 72: 2,578 lbs. (includes steel angle; but no burner, flue, accessories)
 - c. Maximus Linear w/ Glass Front - 96: 3,132 lbs. (includes steel angle; but no burner, flue, accessories)
 - d. Maximus Linear w/ Glass Front - 120: 3,844 lbs. (includes steel angle; but no burner, flue, accessories)
- 2) Approximate weight of log set: 100 lbs.
- 3) Fire brick and Adhesive: 350 lbs. - 1800 lbs. depending on brick size and pattern
- 4) Facing material: per general contractor
- 5) B-Vent metal flue: per manufacturer and installation requirements

The floor area for each model is as follows:

- Maximus Linear w/ Glass Front – 48: @ 53" x 28" = 10.3 sq. ft.
- Maximus Linear w/ Glass Front – 72: @ 85-3/4" x 28" = 16.67 sq. ft.
- Maximus Linear w/ Glass Front – 96: @ 108-1/4" x 28" = 21.04 sq. ft.
- Maximus Linear w/ Glass Front – 120: @ 131-3/4" x 28" = 25.62 sq. ft.

Earthcore is not responsible for structural floor support details for this fireplace system. Unless otherwise noted all floor framing drawings in this manual are merely illustrations to indicate the presence of an underlying floor system. Consult your local structural engineer for proper floor system design, sizing, and specifications.

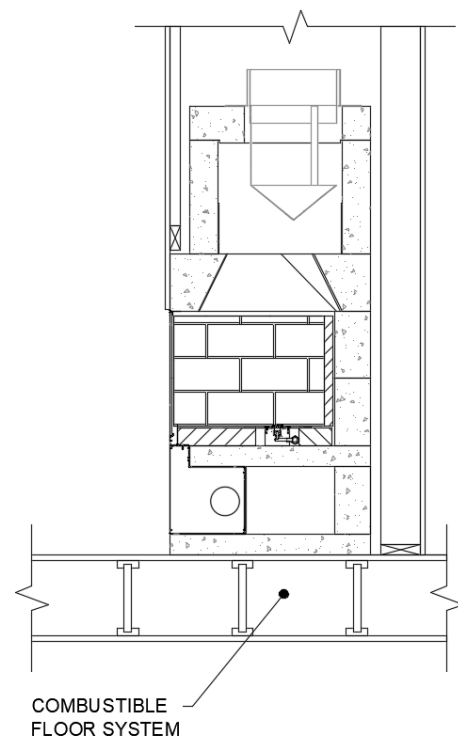

FIGURE 3

Rough Framing Dimensions

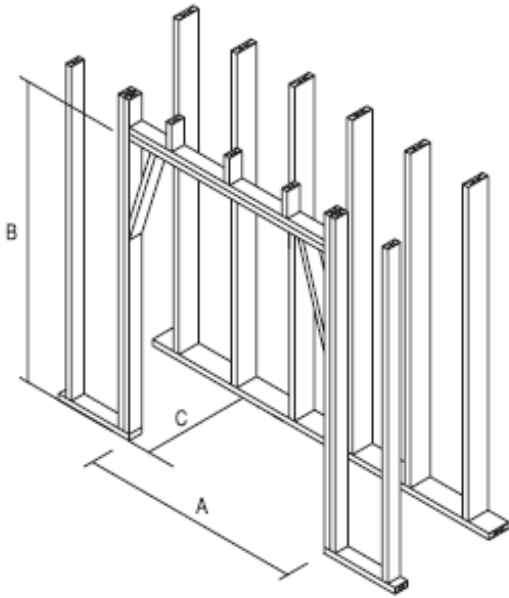

FIGURE 4

TYPICAL INSTALLATION FRAMING DIMENSIONS			
Model #	A - Width	B - Height	C - Depth
82L48	56"	64-1/2"	29-1/2"
82L72	89"	64-1/2"	29-1/2"
82L96	112"	64-1/2"	29-1/2"
82L120	135"	64-1/2"	29-1/2"

NOTES:

- 1) "B" includes the required 3" thick base plate.
- 2) If the Maximus Linear Open Front installation is to be elevated, this "Raised hearth" installation will require additional rough opening height at "B" that is equal to the height of the raised hearth.
- 3) Rough framing dimension for depth "C" allows for the required 1-1/2" clearance at the back of the fireplace. Note that this 29-1/2" is typically used on interior walls that do not have insulation present.

IMPORTANT: Unless the insulation on an exterior wall is installed behind plywood sheathing, a depth of 31" is often used to account for the required 3" clearance to insulation. Even with this increased distance, the installer should be aware that spray foam insulation may expand past the face of the stud wall and will require trimming prior to firebox installation to maintain the required 3" clearance. It is important that any insulation that is not installed behind sheathing shall be installed in such a manner that it cannot fall on the firebox and encroach on this clearance. **(Figure 4)**

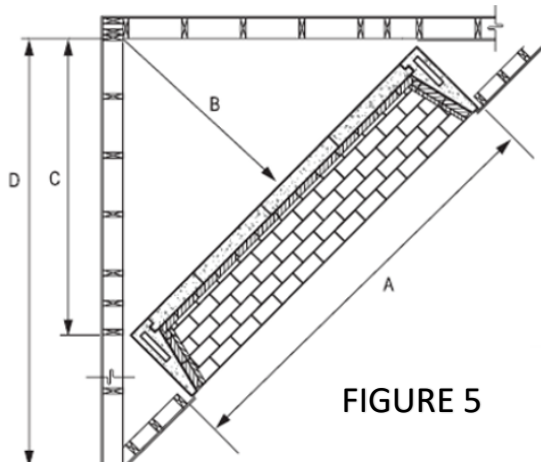

FIGURE 5

CORNER INSTALLATION FRAMING DIMENSION

The following chart of dimensions detail the positioning of a Linear Series fireplace in a corner. **(Figure 5)**

CORNER INSTALLATION FRAMING DIMENSIONS				
Model #	A	B	C	D
82L48	56"	29-1/2"	39"	80"
82L72	89"	45"	62-1/2"	103-1/2"
82L96	112"	56-1/2"	78"	119"
82L120	135"	68"	95"	136"

Rough Framing Dimensions

RAISED HEARTH INSTALLATION OPTION: If the design preference is for a raised hearth (floor of the fireplace elevated above the room’s floor), the base plate can be set on a platform that is built up to the desired raised hearth height. When calculating raised hearth height, be sure to allow for the 3”-thick base plate plus the 2-1/2”-thick fire brick floor in addition to the height of the platform. The platform shall be designed to accommodate the full weight of the firebox, venting, and accessories.

For all “raised hearth” construction - even where concrete blocks are used to create the raised platform, it is still mandatory to use the Isokern base plate. Be sure to Earthcore Adhesive the concrete block platform together. All CMU used for base plate support should be rated ASTM 90.

CAUTION!!: The top of the hearth extension installed with the Maximus Linear with Glass Front shall not be above a point as measured 1/2” below the Glass Support Channel’s outside flange. Failure to plan for and adhere to this requirement will prohibit the installation of the glass panels (**Figure 6**).

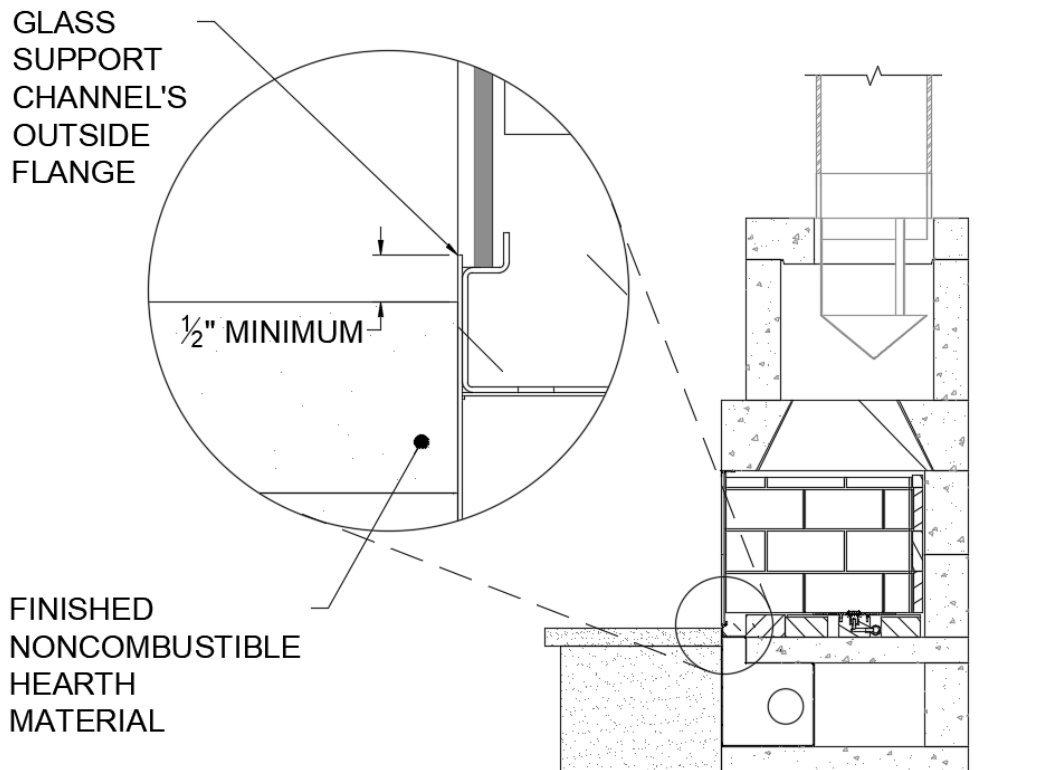

FIGURE 6

General Assembly Instructions

When beginning the assembly process, mix the Earthcore Adhesive with clean water to a smooth, workable texture (without lumps or dry pockets) of a “toothpaste” consistency. This mixture is suitable for application onto Isokern components by using a masonry grout bag supplied with the unit.

Attention should be paid that the Earthcore Adhesive mixture is not too thin or runny, as this will not allow the Earthcore Adhesive to reach its maximum bonding strength.

Mark out the position of the base plate on the supporting floor system. Apply a thin layer of Earthcore Adhesive to the area and set base plate in the adhesive (**Figure 7**).

Earthcore Adhesive is then squeezed from a grout bag onto the contact surfaces of the Isokern components as they are fitted together.

NOTE: It is important that a ½” bead of Earthcore Adhesive is piped onto all the components’ contact surfaces, about ½” in from all edges (**Figure 8**).

When setting the next component onto the Earthcore Adhesive contact surface of the base plate, some Earthcore Adhesive should squeeze out along the face of the entire joint as a sign of complete and proper sealing of the joint.

On broader contact surfaces, it is advisable to apply several additional ½” beads of the Earthcore Adhesive to the area to assure proper sealing of the joint.

Proper firebox and smoke dome assembly requires approximately 100 pounds (dry measure) of Earthcore Adhesive.

LEVELING AND ALIGNING COMPONENTS:

Be sure to assemble all Isokern components level and flush with adjoining components.

Earthcore Adhesive is not intended to create a joint of any thickness for leveling purposes. Leveling and alignment adjustments are accomplished with the use of small plastic shims supplied with the unit (**Figure 9**).

The shims may be inserted under a component to level and align it with adjacent Isokern components. Be sure to re-grout all gaps resulting from shim insertion to maintain components to full bearing.

BROKEN COMPONENTS:

Components can be repaired by using Earthcore Adhesive along the break line as the component is set into place.

Components broken into multiple small pieces should be discarded and replaced.

IMPORTANT:

- Do not mix Earthcore Adhesive with anti-freeze agents.
- The maximum recommended Earthcore Adhesive joint thickness between Isokern components is ¼”.

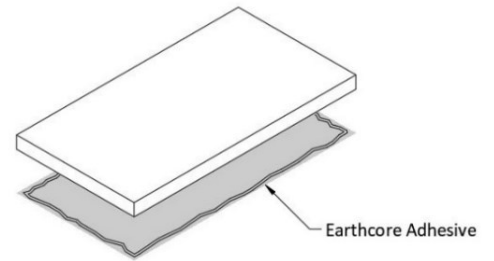

FIGURE 7

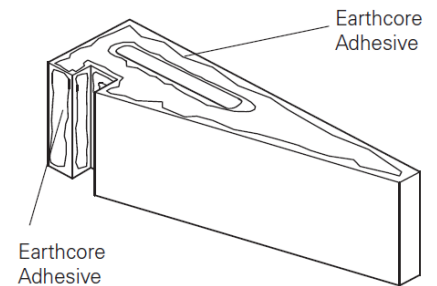

FIGURE 8

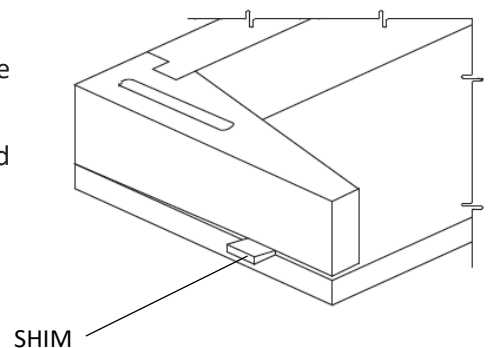

FIGURE 9

Isokern Maximus Linear Glass Front Installation

The following assembly instructions identify the parts by name, part number, and illustrate the placement of each part in the assembly process for the Maximus Linear Fireplace with Glass Front.

NOTE: At all component joints, be sure to mortar all contact surfaces with Earthcore Adhesive. Check for complete sealing of each contact joint as the assembly progresses.

- 1) Apply Earthcore Adhesive to the joints between each baseplate part and ensure to set each base plate in a full bed of Earthcore Adhesive on a level support surface (**Figure 10**). See page 19 for information regarding the supporting floor system. Do not set the base plate so that it is in span. Refer to pages 6 - 17 for firebox and part dimensions.

IMPORTANT: ALL COMPONENTS OF BASE PLATE ASSEMBLY SHALL BE LEVEL, FLUSH, AND ALIGNED WITH EACH OTHER.

- 2) Set the first course of the firebox side walls and back walls into place (**Figure 10**).

NOTE: It may be convenient to dry set the first course of back walls and side walls in place on the Isokern base plate and then trace their position onto the base plate. After outlining the dry set pieces, remove them and apply Earthcore Adhesive to the areas traced on the base plate. By doing this, the first layer of wall components can be set directly into Earthcore Adhesive already applied to the proper areas on the base plate.

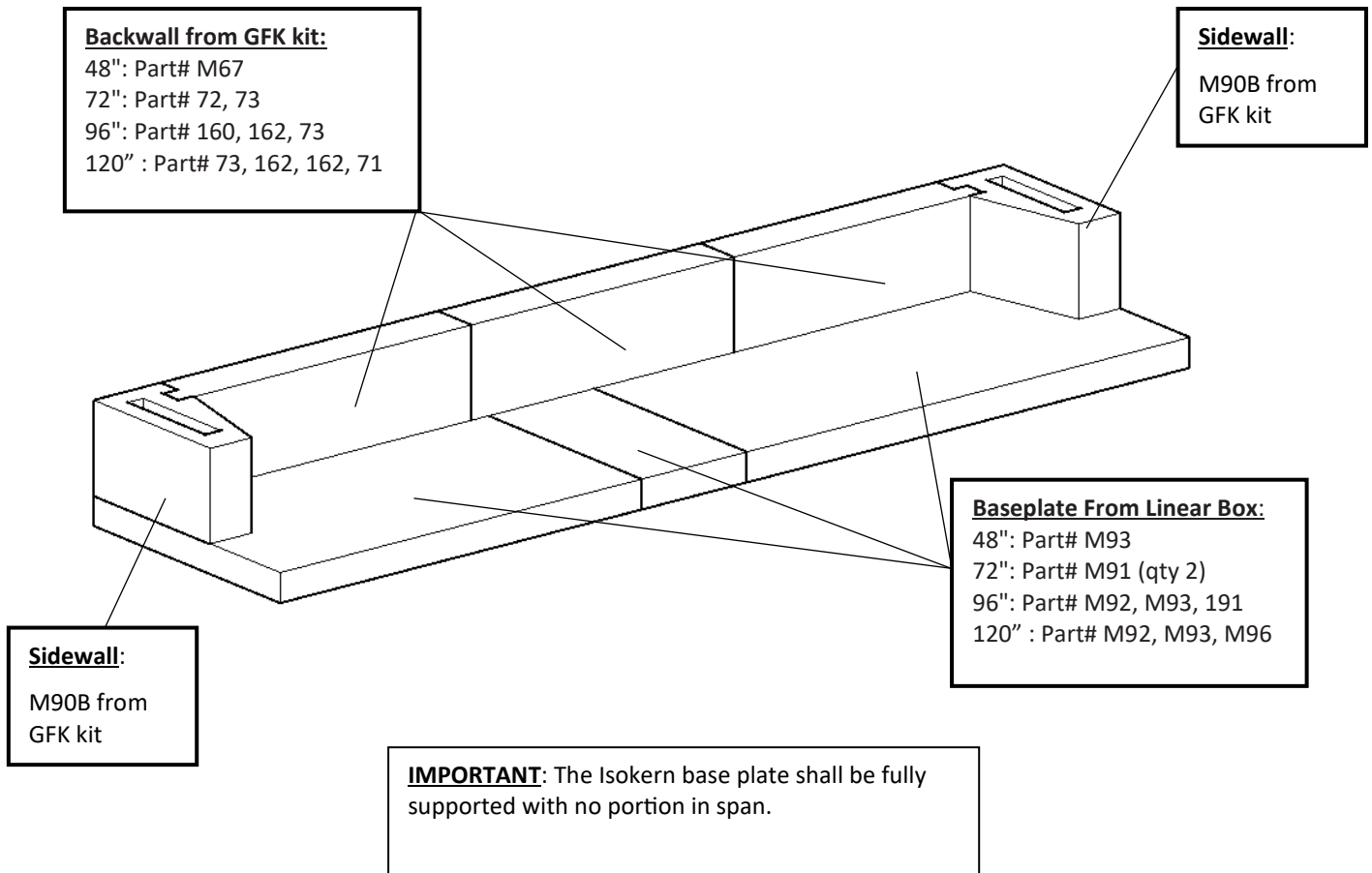

FIGURE 10

Isokern Maximus Linear Glass Front Installation

3) The Air Collector Box Assemblies will be placed on top of the base plate(s) as shown (**Figure 11**).

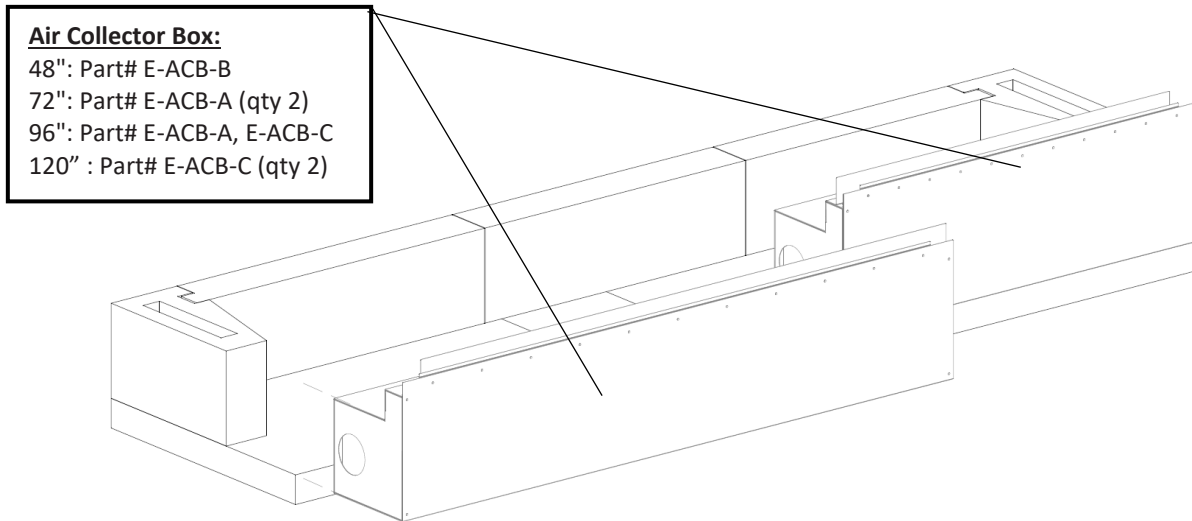

FIGURE 11

CAUTION!!: The Glass Support Channels of the Air Collector Boxes must be aligned in the vertical and horizontal planes. Failure to align these channels will prevent installation of the glass panels (**Figure 12**).

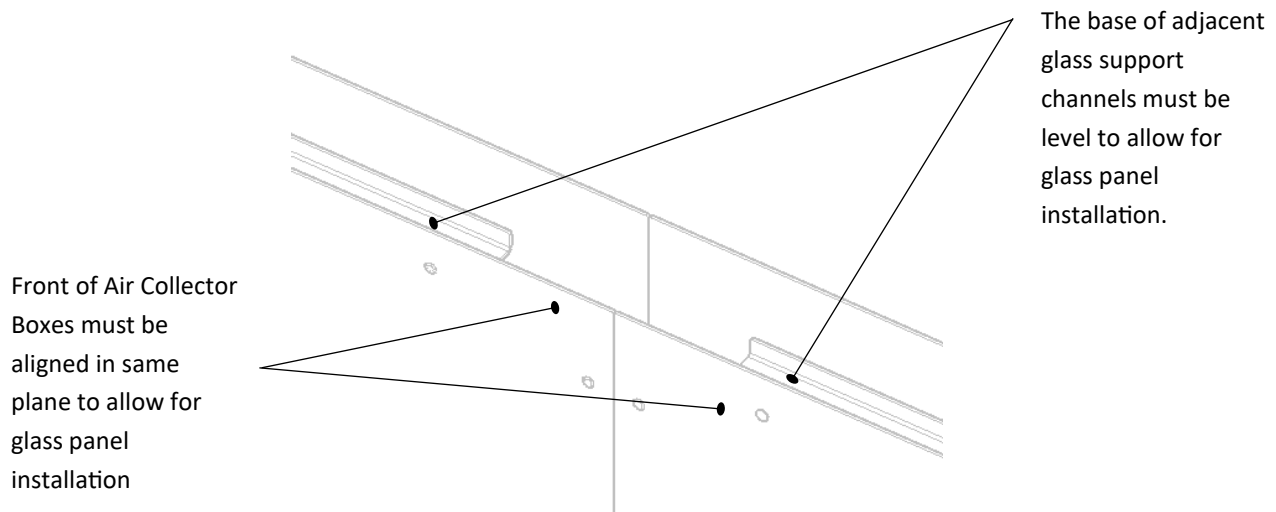

FIGURE 12

CAUTION!!: The top of the hearth extension installed with the Maximus Linear with Glass Front shall not be above a point as measured $\frac{1}{2}$ " below the Glass Support Channel's outside flange . Failure to plan for and adhere to this requirement will prohibit the installation of the glass panels.

Isokern Maximus Linear Glass Front Installation

- 4) Place the next layer of baseplates from the Glass Front Kit, GFK. These baseplates should rest on the previous layer of back and sidewalls, with the front of the baseplates resting atop and flush with the Air Collector Box shelf. **(Figure 13)**.

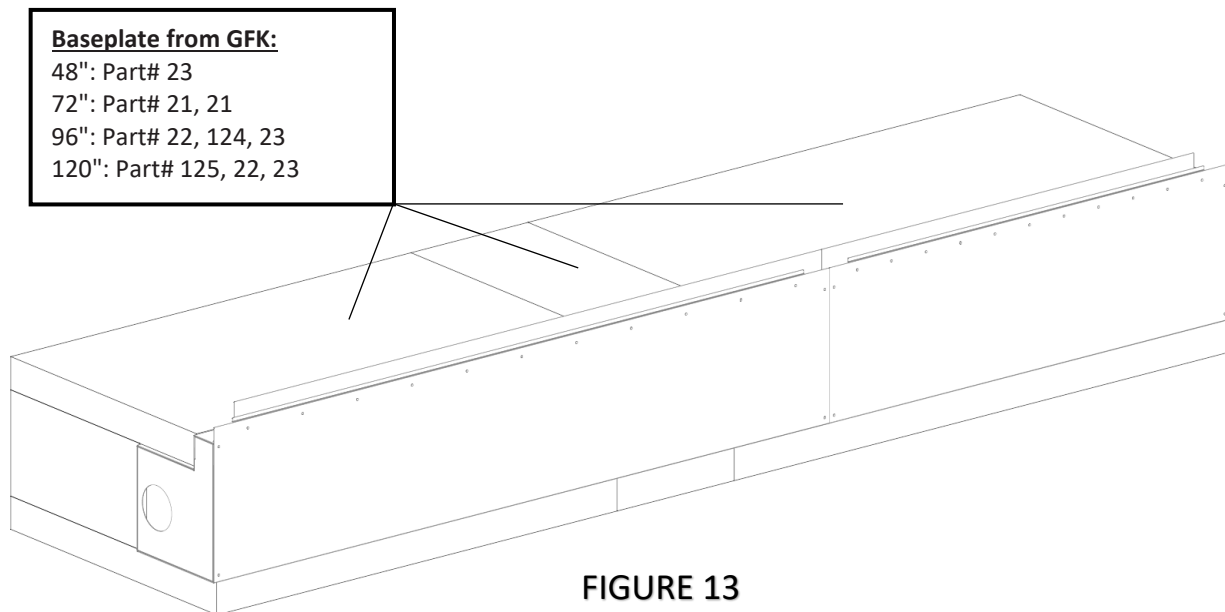

FIGURE 13

- 5) Continue assembly of the consecutive courses of the firebox side and backwalls, making sure to stagger the back wall components so that the vertical joints do not align. Apply Earthcore Adhesive to the top of each layer of side wall components before setting the next course in place **(Figure 14)**. Look for some Earthcore Adhesive to squeeze out along the joints of all contact surfaces as a sign that the joint is thoroughly sealed with the approved Earthcore Adhesive.

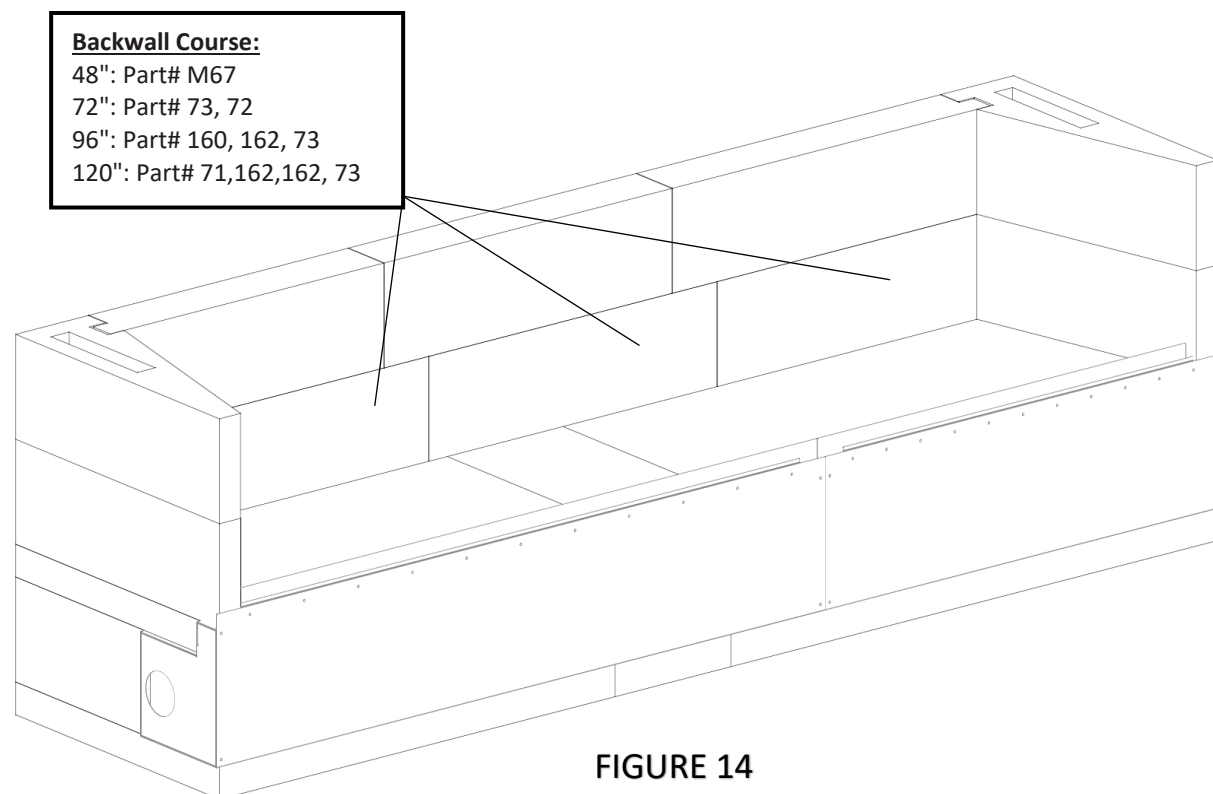

FIGURE 14

Isokern Maximus Linear Glass Front Installation

- 6) When all the firebox side wall components are set, check the top surface of the firebox for level. If necessary, adjust the top surface of the box assembly for level by inserting a shim supplied with the unit between the lowest wall component and the top surface of the base plate. Any gap created under the wall components during the shim leveling process must be filled with Earthcore Adhesive.
- 7) Steel angle iron with measurements of 6" x 6" x 1/2" cut to span the width of the firebox will be needed to assemble the 72", 96", and 120" fireboxes (not required for the 48" model).

CAUTION!!: FAILURE TO UTILIZE THIS EXACT SIZE ANGLE WILL RESULT IN INABILITY TO COMPLETE THE FIREBOX ASSEMBLY

It is necessary to cut two 1/2" deep recesses to properly seat the angle iron. These recesses shall begin at the front of the top sidewall components and extend 5 1/2" towards the center of the firebox. These notches ensure that the angle iron is level and flush with the top of the side wall components (**Figure 15**).

When properly installed, the angle iron rest in this notch and will protrude 1/2" beyond the front edge of the side wall component.

NOTE: It is not necessary to apply Earthcore Adhesive between angle and Isokern sidewall components.

NOTE: The steel angle should not be longer than the width of the firebox.

NOTE: Angle iron is not included, but is required for installation.

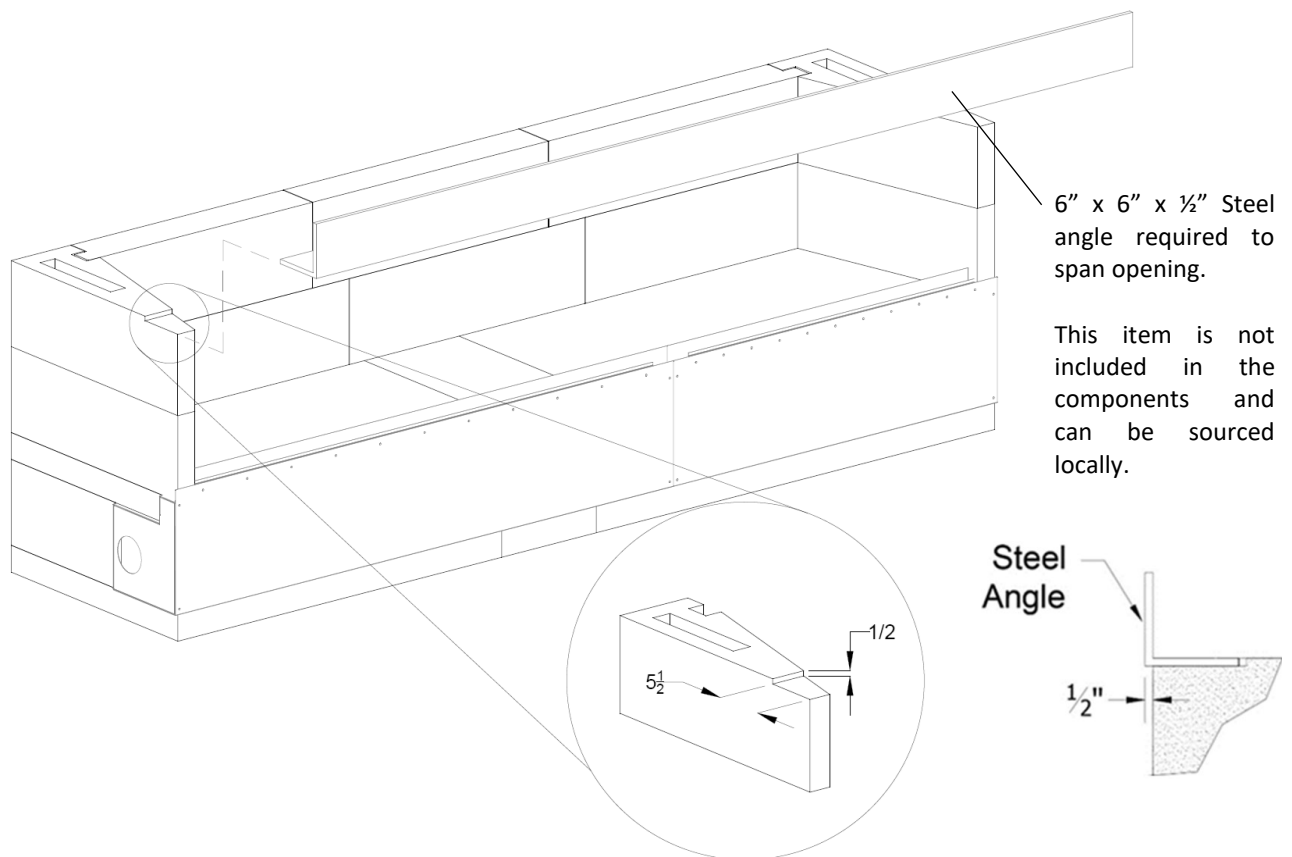

FIGURE 15

Isokern Maximus Linear Glass Front Installation

- 8) The fireplaces come with an 8”- thick damper beam assembly, a component group that is to be assembled on top of the firebox side walls and steel angle iron (no steel angle iron in 48” model).

The damper beam assembly consists of long lintel pieces and two (2) short damper end blocks. The lintels will be equal to the width of the fireplace model that they serve. These components both sit on their narrow base so that their beveled face points down and into the firebox interior (**Figure 16**).

The damper end blocks are designed to sit on the firebox side wall between the front lintel and the back lintel. Each of the damper end blocks are designed for a specific side of the unit. When properly set, the vertical face of the damper end block will be flush with the outside face of the firebox side wall and the widest angled face should be oriented towards the rear. (**Figure 16**).

Begin by setting the rear Damper Beam components into place. Next, set the Damper End Blocks into place atop the sidewalls in a bed of Earthcore Adhesive. Be sure to apply Earthcore Adhesive to the contact surfaces of each Damper End Block component where it will meet the front and back damper beam lintel components. Next, set the front Damper Beams into place.

NOTE: Be sure to apply Earthcore Adhesive to contact surfaces between all Isokern components

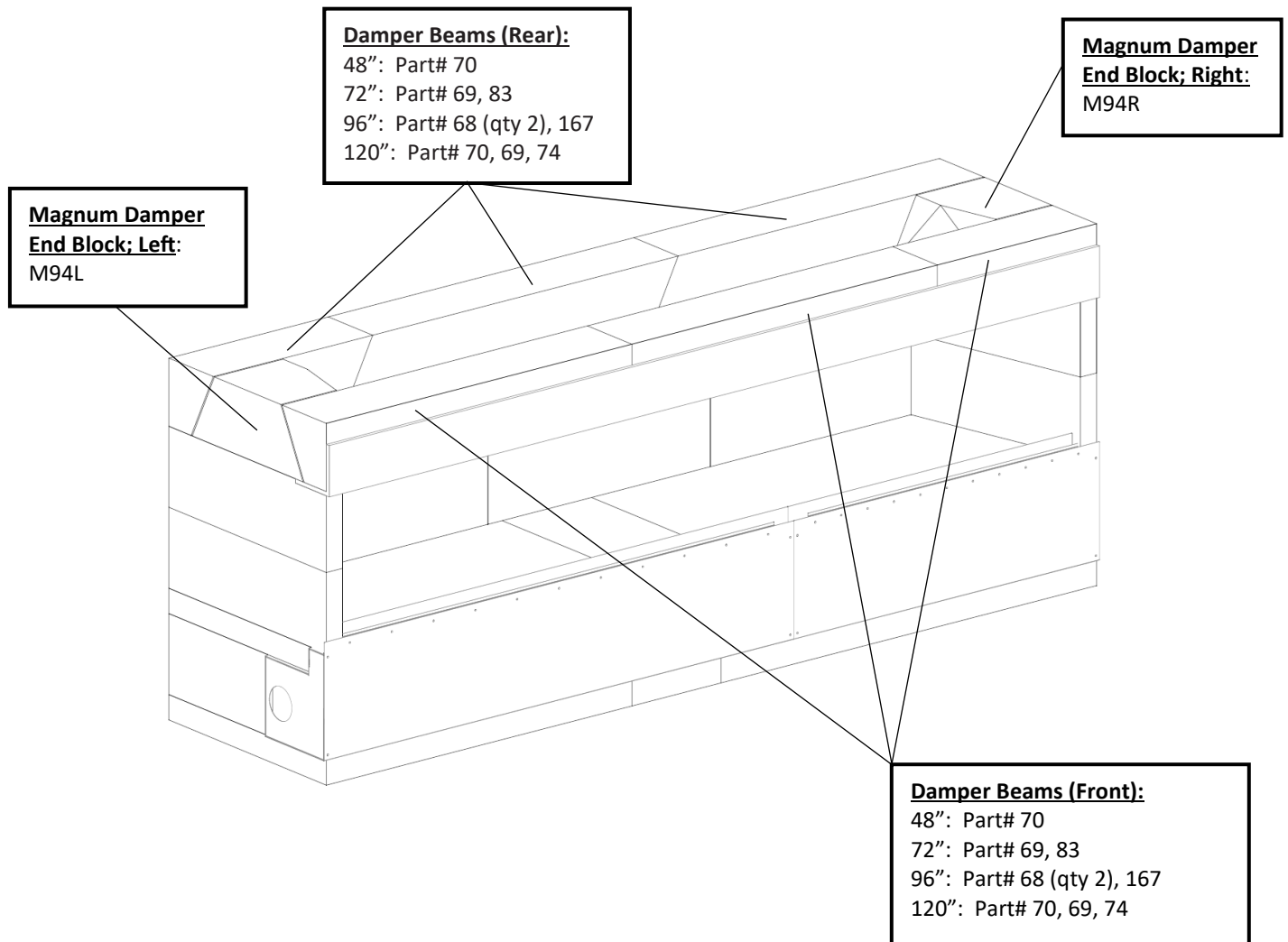

FIGURE 16

Isokern Maximus Linear Glass Front Installation

- 9) For the 72", 96" and 120" models, once the dampers beams are set into place, secure the Top Glass Bracket A (E-TG2) in place with the bottom of the angle steel as shown (**Figure 17**). Each model will require a different number of these to be spaced equally across the firebox's opening. Tap them into place utilizing a rubber mallet to prevent marring the finish.

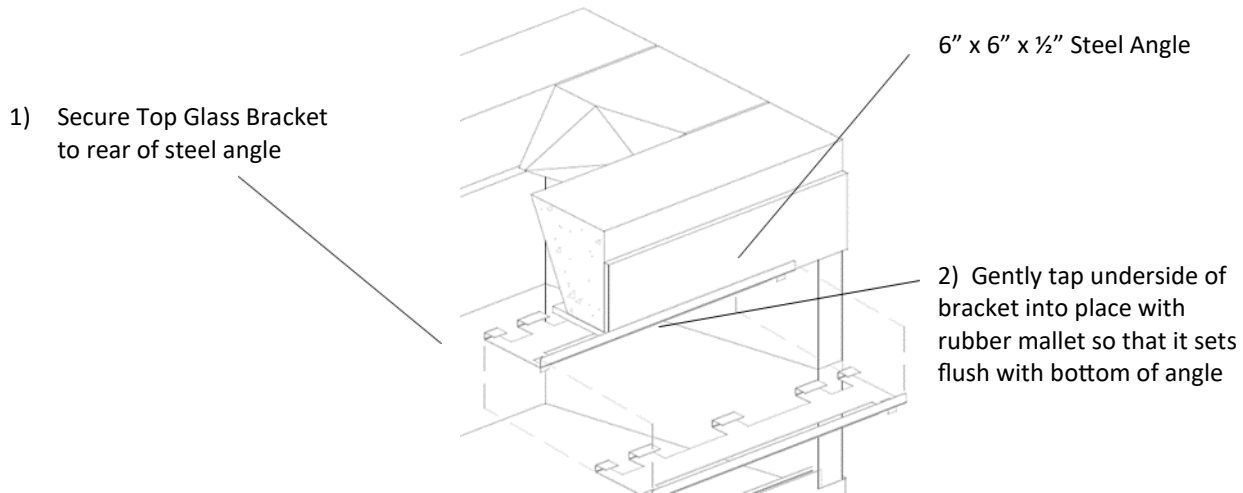

FIGURE 17

- 10) For the 48" model, secure the Top Glass Bracket B (E-TG1) to the underside of the front damper beams using the provided 1/4" tap-con screws. The tap-con screws will require a 3/16" pilot hole to be drilled prior to attachment. It is recommended to coat the 1/4" tap-con screw with Earthcore Adhesive before inserting into pilot hole to create a sealed fastening (**Figure 18**).

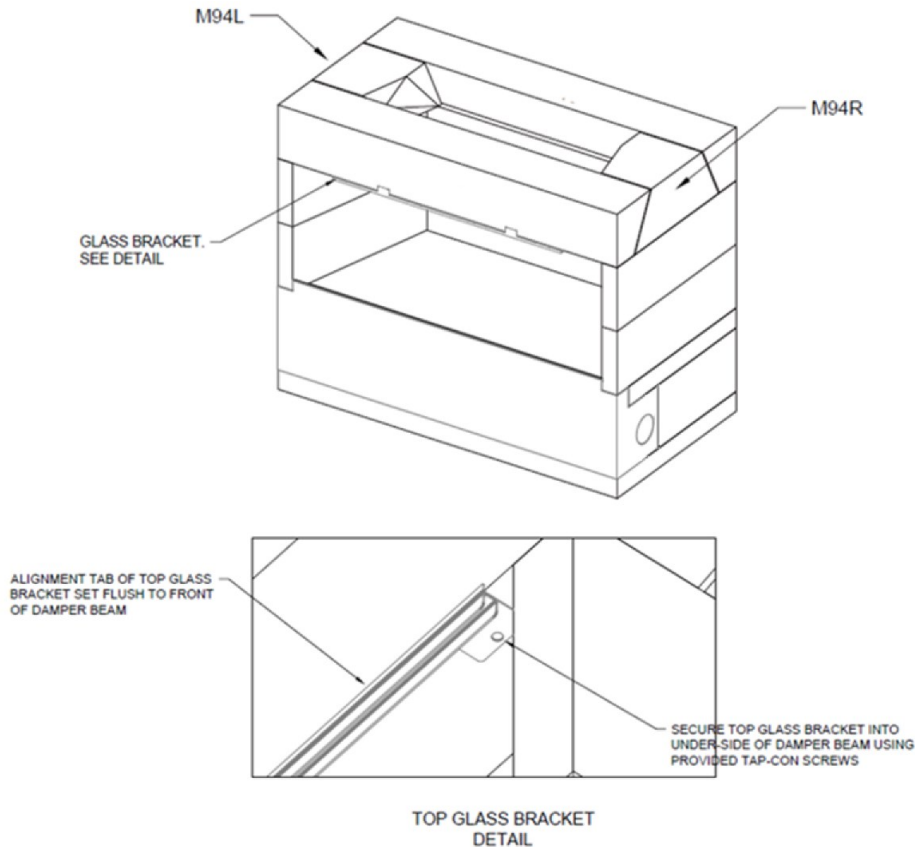

FIGURE 18

Isokern Maximus Linear Glass Front Installation

11) Set the rear smoke dome component(s) across the damper beam in a bed of Earthcore Adhesive and flush with the back face of the rear damper beam lintel.

Apply Earthcore Adhesive along the entire length of the front damper beam; bead should be 3” from the front edge. Place the front smoke dome component(s) on the bead of Earthcore Adhesive so that approximately a 17” gap exists between the front and rear smoke dome components (**Figure 19**).

12) With the front/rear smoke dome components in place, apply Earthcore Adhesive to all adjoining surfaces of the sloping sidewall components. The sloping side walls will be placed in between the front and rear smoke dome components at the ends of the firebox and are designed to rest in their notched ends. Once assembled, compress the smoke dome components by applying pressure to the front/rear of the smoke dome assembly to force the components together. Repeat this process on the opposite side of the firebox (**Figure 19**).

13) Apply Earthcore Adhesive on top of the smoke dome assembly and set the top plates into position as shown (**Figure 19**).

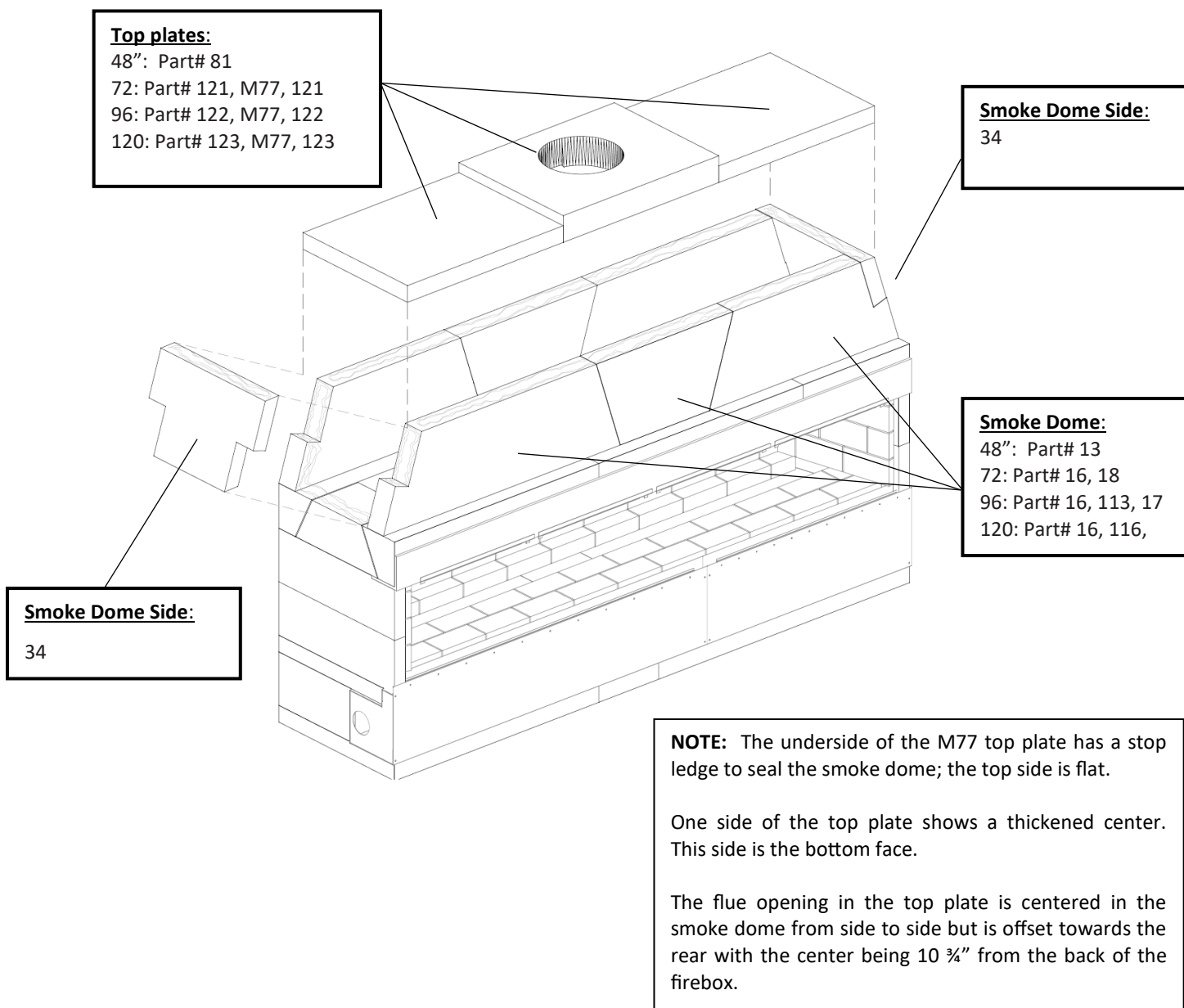
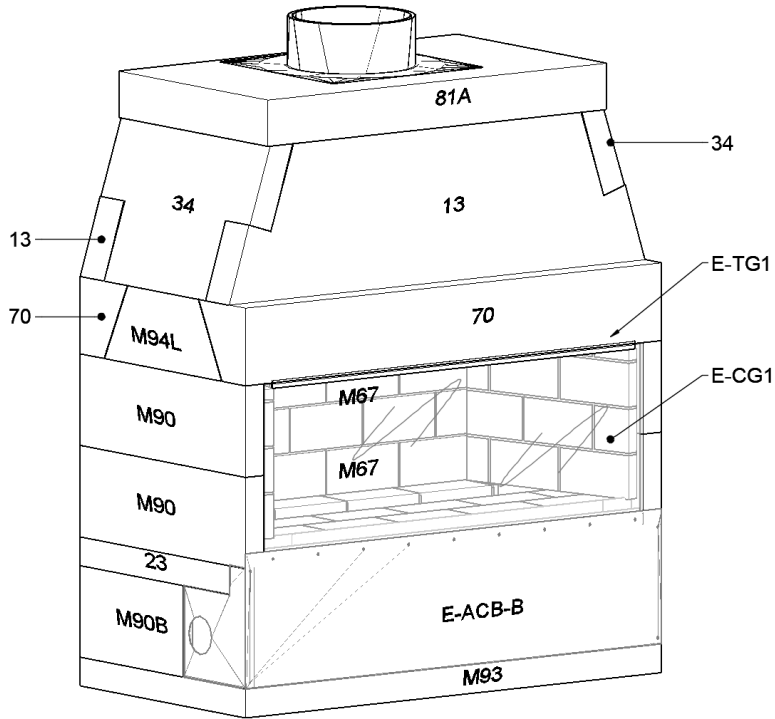

FIGURE 19

Assembled Maximus Linear Glass Front Units



Assembled 48" Maximus Linear w/ GFK (82L48-GFK).

Note: not shown; but required is one cooling air kit.

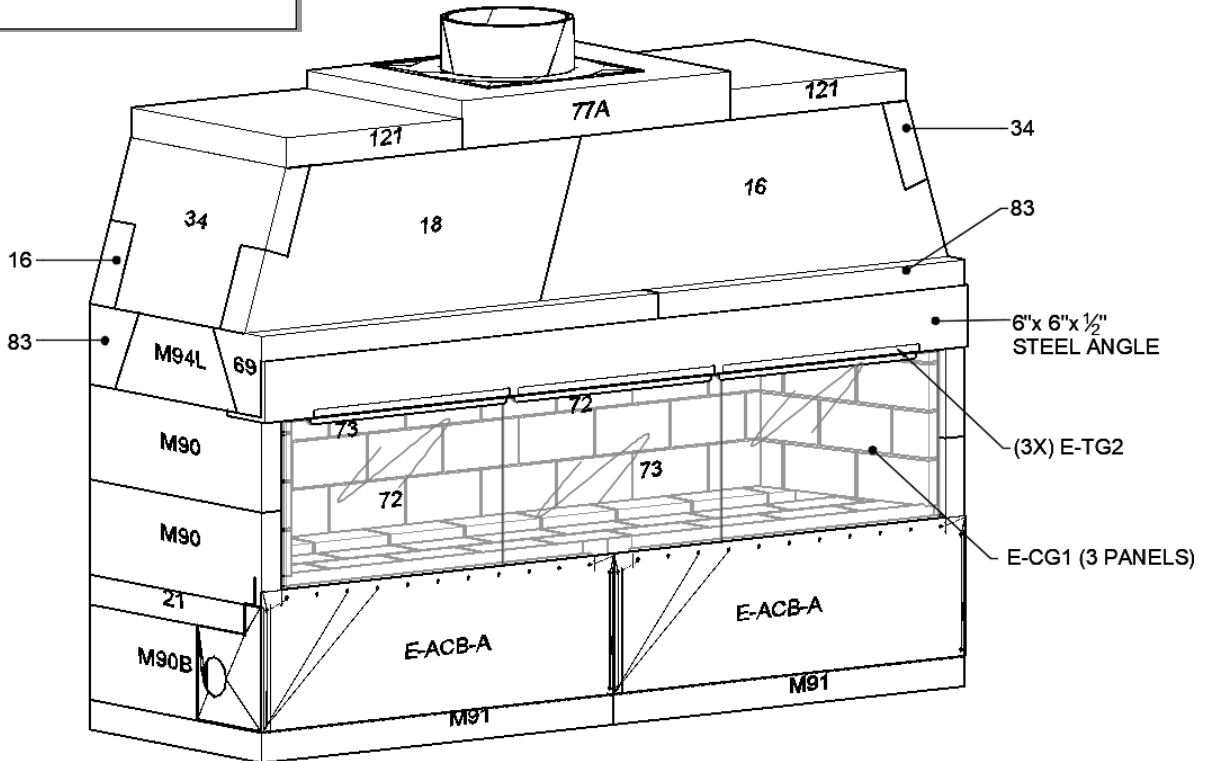

Assembled 72" Maximus Linear w/ GFK (82L72-GFK)

Note: not shown; but required are two cooling air kits.

Assembled Maximus Linear Glass Front Units

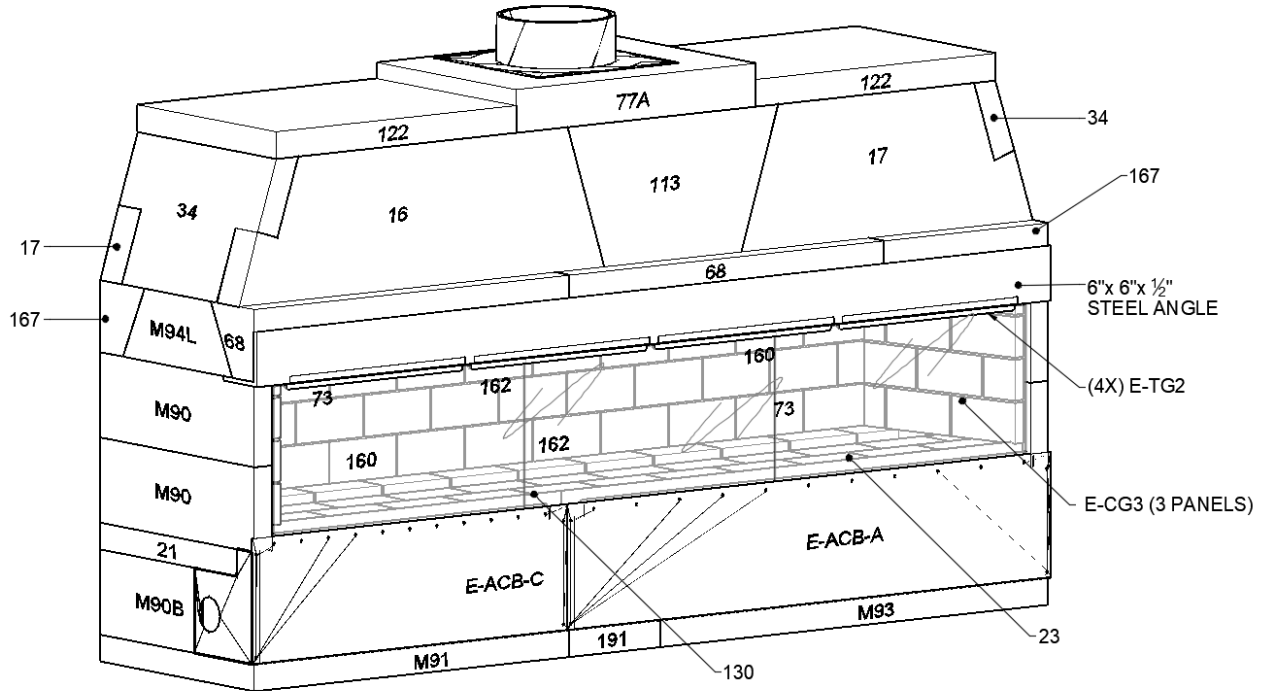

Assembled 96" Maximus Linear w/ GFK (82L96-GFK).
Note: not shown; but required are two cooling air kits.

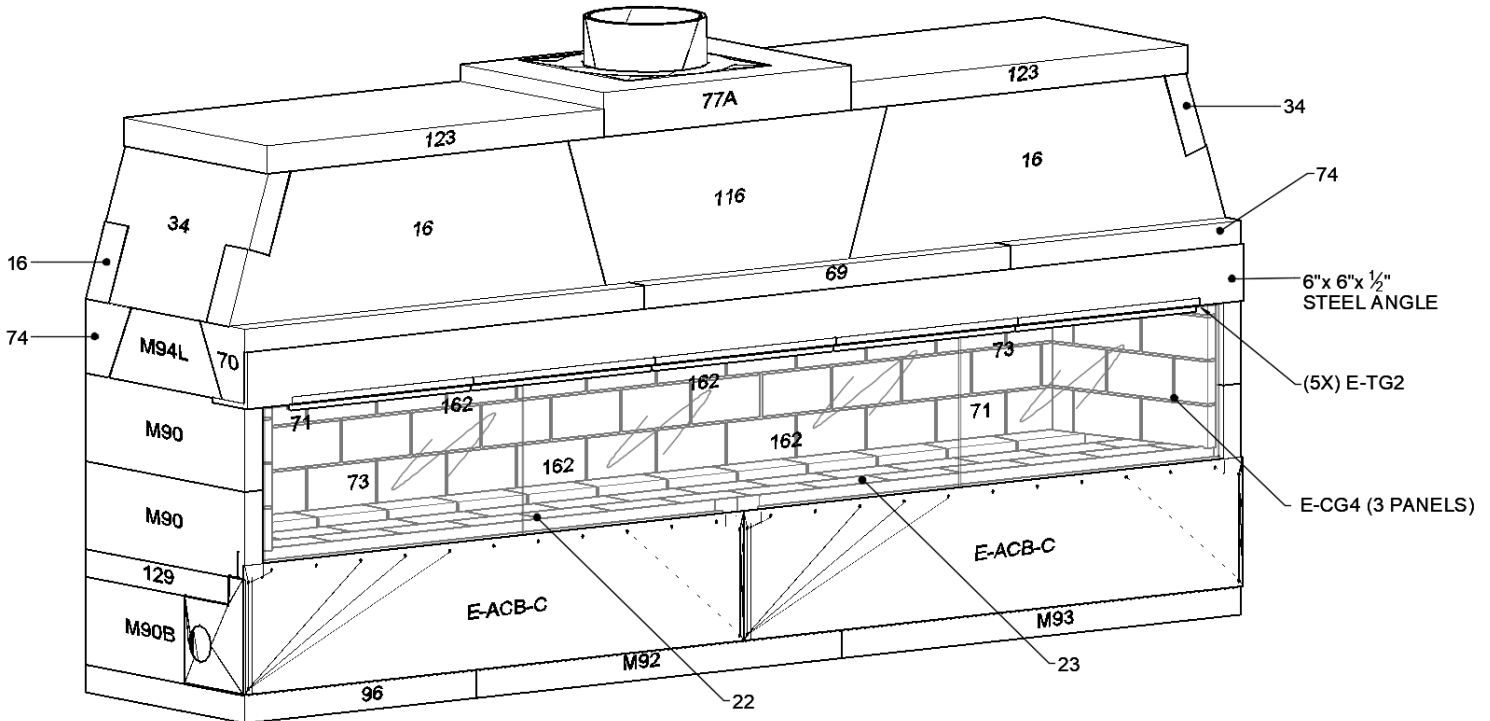

Assembled 120" Maximus Linear w/ GFK (82L120-GFK).
Note: not shown; but required are two cooling air kits.

Access Modification

Combustion/ Cooling Air Kits, Gas & Electrical Line Feed

The Maximus Linear with Glass Front requires 4" cooling air kits to provide cooling air to the glass for safe operation. The 48" model will require one air kit (OAK-12NG), and the 72" 96", and 120" models will require two. (Figures 20 and 21).

ISOKERN LINEAR AIR-KIT COMPONENTS (OAK12NG):

- 4" diameter flexible stainless-steel duct (10' section)
- Stainless steel sleeve (approximately 5") for connection to the Air Collector Boxes
- Exterior vent termination with dress plate
- Weather hood including rodent prevention ¼" mesh screen

The Linear Air Kits are connected to the Air Collector Boxes using the provided screws and routed as directly as possible to an outside air source.

During fireplace operation, the Maximus Linear Series' mechanical draft fan will draw cool air from outside the building and across the glass panels to maintain acceptable temperature of the glass during fireplace operation.

IMPORTANT: It is highly recommended that the air kit duct be routed in the most direct path to the outside wall of the building. Air kits are supplied with 10' duct sections. It is recommended not to exceed twenty feet (20') of four-inch (4") duct. If a longer length is required, it is recommended that a six-inch (6") diameter duct be utilized, extending the run up to forty feet (40').

WARNING!!!: Do not use combustible duct material. Avoid installing a cooling air inlet where the opening could be blocked by snow, bushes, or other obstacles. Air inlet ducts shall not terminate in attics, basements, or garage spaces.

GAS LINE FEED

All Maximus Linear fireplaces require a ¾-1" hole be drilled into the sidewall for the installation of 3/8" hard-piped gas supply to the Isoflames Linear Burner. Ensure all holes are filled with Earthcore Adhesive after installation (Figure 22).

ELECTRICAL LINE FEED

All Maximus Linear fireplaces require a ¾-1" hole be drilled into the side wall for the connection of the pilot assembly gas and electrical connections. Be sure to follow the explicit electrical line connection instructions for the Isoflames Linear Burner and mechanical ventilation system as detailed in this manual. Ensure all holes are filled with Earthcore Adhesive after installation

(Figure 22).

NOTE: Main gas line and electric line must be fed through separate access holes.

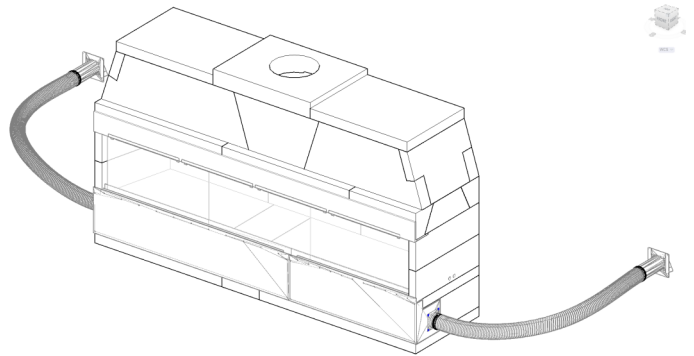

FIGURE 20

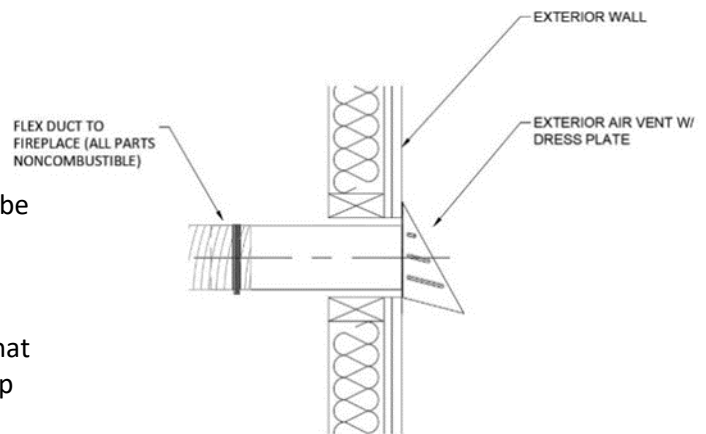

FIGURE 21

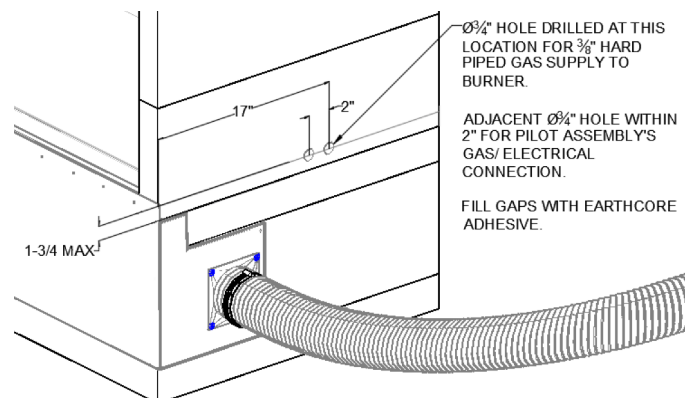

FIGURE 22

B-Vent Metal Chimney - General Information

The Maximus Linear Series with Glass Front Fireplaces are tested and listed for use only with the specified factory-built metal B-Vent chimney system as detailed in this manual. All Maximus Linear fireplace systems require 12" Metal-Fab Type-B Gas Vent Chimney System with Anchor Plate with Down-Draft Diverter. This chimney has a 12" Inner Diameter (I.D.) and a 13" Outer Diameter (O.D.). Frame all openings to 15" X 15" clear to maintain minimum 1" clear air space around the pipe at all times..

APPROVED MANUFACTURERS

Metal-Fab® (UL 441 & ULC S605) Type B Gas Vent

IMPORTANT INSTALLATION GUIDELINES

- Install the Maximus Linear fireplace as described in this installation manual and maintain all required clearances.
- Proper planning for your B-Vent Chimney installation will result in enhanced safety, efficiency, and convenience. You must use only B-Vent Chimney parts and components to maintain a listed chimney system. Do not mix parts or try attempt to match with other products or use improvised solutions.
- The selected, approved chimney manufacturer must provide the masonry anchor plate with down draft diverter designed to fit the flue system.
- All chimneys and chimney liners must be installed in accordance with the manufacturer's installation instructions and under the terms of their listing.
- Refer to metal flue manufacturer instructions for information regarding the number of offsets allowed, approved chimney shrouds, clearance to combustibles, and or any information specific to that flue system. B-Vent Chimney is not designed for use on products that operate at continuous temperatures more than 1000°F.
- Never fill any required clearance space with insulation or any other building materials surrounding the chimney. B-Vent chimney pipe requires one (1") air space clearance. Do not place any material within the required one (1") clearance zone. The vent pipe listing may be voided if the clearance requirement is not adhered to.
- Except for installation in one- or two-family dwellings, a factory-built chimney that extends through any zone above that on which the connected appliance is located is to be provided with an enclosure having a fire resistance rating equal to or greater than that of the floor or roof assemblies through which it passes.
- Interior chimneys shall be enclosed where they extend through closets, storage areas, occupied spaces, or anywhere the surface of the chimney could be contacted by persons or combustible materials. The air space between the outer wall of the chimney and the enclosure shall not be less than 1 inches.
- Exterior metal parts of the chimney, with exception of the mechanical draft components, can be painted with a high temperature rust proof paint. Wash the metal surface with a vinegar and water solution to remove any residue before painting. Painting the chimney will help to increase chimney life.
- In cold climates, chimneys routed outside of the building should be enclosed in a chase. Exterior chases reduce condensation and enhance draft.

IMPORTANT: A major cause of chimney related fires is failure to maintain required clearance (air spaces) to combustible material. Minimum clearance for 12" diameter B-vent chimney is one (1) inch. It is of utmost importance that this chimney system is installed only in accordance with these instructions.

B-Vent Metal Chimney - General Information

- Connect only one fireplace per chimney. Follow the fireplace safety manual for maximum efficiency and safety. Do not over fire. Any damage to the fireplace or chimney can possibly void the warranty.
- Do not burn food, wood, driftwood, plastic, or chemically treated wood such as railroad ties. They are corrosive to your chimney system. Use of any fuel other than gas on burner rating plate will void the warranty of this fireplace and is prohibited. **THIS IS A GAS ONLY FIREPLACE.**
- When installing B-Vent always align “Up” arrow away from appliance.
- Chimneys must be installed so that access is provided for inspection and cleaning.
- If the installation must pass through an attic, floor, or ceiling the B-vent Firestop shall be utilized. To pass the pipe through the floor/ ceiling, begin by cutting a hole in the floor/ ceiling that is 2 inches larger than the outside diameter (OD) of the B-vent pipe’s outer casing. The B-vent Firestop is installed at the underside of this penetration. The B-Vent pipe is to be centered in the firestop’s opening. When installed, check to make sure the one-inch (25.4 mm) clearance to combustible has been maintained.

NOTE: If the area above the ceiling/ floor penetration is an attic, the firestop shall be installed above the joist to prevent insulation from filling the required clearance area between the pipe and joists.

- 45° Elbows are available to install the B-vent chimney around obstructions. If the installation requires more than two 90-degree offsets, contact your local Isokern sales representative for assistance.









NOTE: Two 45° elbows may be combined to achieve 90° offset to run the pipe horizontally . If space allows, It is preferred to install a length of straight B-vent pipe between elbows when a 90° offset is required.

- If the installation contains a horizontal run that passes through any combustible wall, a wall thimble is to be utilized at each wall penetration.
- For horizontal and lateral runs, it is recommended that support be used every 5 feet (1524 mm), and that each individual pipe section is individually supported. Plumber’s straps are commonly used. They should be positioned to maintain 1 inch (25.4 mm) clearance to combustibles.
- Horizontal runs of pipe should be sloped upwards towards the termination at a minimum of 1/4” rise per foot.
- A venting system that terminates in the sidewall of a structure shall terminate at least 3 ft (0.9 m) above any air inlet to the structure that is within 10 ft (3 m) of the termination point.

NOTE: The flue gas outlet of this appliance shall terminate at least 4 ft (1.2 m) below, 4 ft (1.2 m) horizontally from, or 1 ft (0.3 m) above any door, window, or gravity air inlet of the structure. The outlet also shall terminate at least 1 ft (0.3 m) above grade.

- A B-Vent support plate (MSP) is required if vertical height exceeds 30 feet. Maximum of 30 feet between supports.

B-Vent Metal Chimney & Components

Component	Part#	Description	Component	Part#	Description
	12M12	B-Vent 12" Length		12MGR	B-Vent Guy Ring
	12M18	B-Vent 18" Length			
	12M24	B-Vent 24" Length		12MF	B-Vent Standard Flashing
	12M3	B-Vent 3' Length			
	12M4	B-Vent 4' Length			
	12M5	B-Vent 5' Length			
	12M12A	B-Vent 12" Adjustable Length		12MFS	B-Vent Firestop
	12M18A	B-Vent 18" Adjustable Length			
	12M45	45 Deg Adjustable Elbow		12MSC	B-Vent Storm Collar
	12MDD	12" B-Vent Draft Diverter			

General Venting Requirements

The Maximus Linear fireplaces utilize mechanical ventilation assistance and may terminate vertically or horizontally. The venting paths to the termination may be vertical, horizontal, or a combination of vertical and horizontal paths. Each termination type will have specific installation requirements based on the location and placement of the mechanical draft systems components, but all installations must adhere to limits shown in Table 1.

	Minimum	Maximum
Vertical Termination Only	10 feet	75 feet
Horizontal Termination Only	4 feet	75 feet
90° offsets*	0	2
*Note: Sum of all offsets shall not exceed 180° in a run, with maximum offset angle of 90° per offset		

Table 1

NOTE: Contact Earthcore representative for total distances exceeding the table minimums / maximums.

X-VENTISO-Meridian Max Linear Fan System - General Information

- **IMPORTANT:** READ THESE INSTRUCTIONS CAREFULLY PRIOR TO INSTALLATION.
- **IMPORTANT:** INSTALLATION AND MAINTENANCE ARE TO BE PERFORMED ONLY BY QUALIFIED PERSONNEL WHO ARE FAMILIAR WITH LOCAL CODES AND REGULATIONS AND WHO ARE EXPERIENCED WITH THIS TYPE OF EQUIPMENT. PERSONNEL SHOULD HAVE A CLEAR UNDERSTANDING OF **THESE INSTRUCTIONS AND SHOULD BE AWARE OF GENERAL SAFETY PRECAUTIONS.**
- **IMPORTANT:** EXAMINE ALL COMPONENTS FOR POSSIBLE SHIPPING DAMAGE PRIOR TO INSTALLATION.
- **WARNING!!!:** TO REDUCE THE RISK OF FIRE, ELECTRICAL SHOCK, OR INJURY TO PERSONS, OBSERVE THE FOLLOWING:
- **DANGER!** ALWAYS DISCONNECT, LOCK AND TAG ALL POWER SOURCES BEFORE INSTALLING OR SERVICING. FAILURE TO DISCONNECT A **POWER SOURCE CAN RESULT IN FIRE, SHOCK OR SERIOUS INJURY.**
- **CAUTION!** CONSULT AND FOLLOW ALL APPLICABLE NATIONAL, STATE AND LOCAL CODES. THEY WILL SUPERSEDE THIS DOCUMENT.
- **WARNING!** NO INSTALLATION, USE, OR MAINTENANCE SHOULD BE DONE IN AN EXPLOSIVE OR HAZARDOUS ENVIRONMENT.

The X-VENTISO-Meridian Max Linear Fan system has been designed specifically for the Maximus Linear fireplaces. The system enables the operation of the Maximus Linear fireplace series while monitoring and maintaining effective draft in the system. The control accomplishes this by modulation of the fan speed based on a factory set pressure differential between the room and the stack.

The X-VENTISO-Meridian Max Linear Fan system consists of the following components:

- 1) X-VENTISO-Meridian Control Panel
- 2) X-VENTISO-Meridian Room Pressure Probe/Cover Plate, Stack Pressure Probe, and Tubing
- 3) X-VENTISO-Meridian-350 Fan
- 4) X-VENTISO-12" Pipe Adapter for 350 Fan
- 5) X-VENTISO-Meridian Damper Assembly

See Appendix A for connection diagram

NOTE: the X-VENTISO-Meridian Damper Assembly's outer shell/ heat shield is required for 2" clearance to combustibles; without shield clearance to combustibles is increased to 18"





The individual components of the system are connected to the XVENTISO-Meridian Control Panel with unique Molex connectors. This ensures that all components of the system are properly connected to the control.

The Meridian Control Panel interlocks the Maximus Linear fireplace's burner system (Isoflames Linear Burner) to the mechanical draft system via a unique Molex connected wiring harness.

The Meridian Control Panel requires 120 VAC/ 15A circuit for operation. An 120 VAC/ 15A outlet must be provided within reach of the 72" power cord of the Meridian Control Panel.

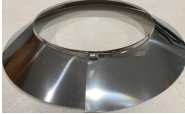
- **NOTE:** an additional 120 VAC/ 15A outlet must be provided for the Gas valve/ controls (E-VK(N/P)) of the Isoflames Linear Burner. This outlet must be placed within reach of the 72" power cord of the Gas Valve/ Control Box.

X-VENTISO-Meridian Max Linear Fan System: Components

Component	Part#	Description	Component	Part#	Description
	XV-MERD-CTLR	X-VENTISO-Meridian Control Panel		XV-350RC	X-VENTISO 350 Rain Collar
	XV-350ADP12	X-VENTISO 12" Pipe Adapter for 350 Fan		XV-MERD-DAMP	X-VENTISO – Meridian Damper Assembly NOTE: Outer shell/ heat shield is required for 2" clearance to combustibles; without shield clearance to combustibles is increased to 18"
	XV-MERD-350	X-VENTISO-Meridian 350 Fan Assembly (shown with XV-350ADP12 attached)		XV-MERD-PRESSKIT	X-VENTISO Meridian Room Pressure Probe/ Cover Plate, Stack Pressure Probe, and Tubing Kit

X-VENTISO-Meridian Control Panel - General Information

The X-VENTISO Meridian Control Panel enables the operation of the Maximus Linear fireplace system while providing real-time monitoring of the fan, damper, and stack pressure to ensure safe fireplace operation. The control panel uses a stack-probe to monitor pressure in the chimney and a room pressure probe to monitor pressure in the room in which the fireplace is installed. The control modulates the fan speed to ensure a slight negative pressure is always kept between the room and chimney, ensuring proper draft is maintained. The control will cease fireplace operation if this set point cannot be achieved/ maintained.

The Meridian Control Panel features a backlit LCD display to provide visual monitoring of system status, settings, and alarms. When the system has a run command, if any one of the 4 conditions exceeds the alarm delay time an alarm activates. If an alarm occurs, the control will annunciate the condition via the LCD and performs safety actions.

After an alarm event clears the control will automatically resume normal operation. If the alarm event is active longer than the fault time parameter, the system will secure operation and lockout requiring a manual reset.

The Meridian Control Panel is sealed from the factory and should require no adjustment of any user parameters. In the event that an alarm occurs and fails to clear, or the fireplace is not operating properly, contact KW at (817)-393-4029.

DO NOT ATTEMPT TO OPEN THE UNIT AND ALTER ANY SETTINGS. THIS WILL VOID THE WARRANTY.

X-VENTISO-Meridian Damper Assembly- General Information

The X-VENTISO Meridian Damper Assembly (**Figure 23**) is a mechanical gas damper that is controlled with the Meridian Control Panel in the Maximus Linear fireplace series. The damper closes when the appliance is not in use to prevent conditioned air from escaping through the chimney, and opens right before the appliance burner fires up.

The damper is wired to the control panel using a unique 4-Pin Molex connection that eliminates the possibility of incorrectly wiring the installation.

The damper may be utilized inline (in the middle of the flue run) for both horizontally and vertically terminating systems. If necessary, it may be used as a termination style damper on vertically terminating flue systems only.

IMPORTANT: Damper must be installed with the provided outer shell to maintain its 2” clearance to combustibles. Without the shell in place, the damper assembly requires an 18” clearance to combustibles. Failure to properly meet these clearances may result in potential fire hazard.

IMPORTANT: Damper must be installed in accessible location

The X-VENTISO Meridian damper is constructed of 316L stainless steel and listed to UL378 – Standard for draft equipment, rated up to 550°F.

System installation must conform to the requirements of the authority having jurisdiction. When required by the authority having jurisdiction, the installation must also conform to the NFPA54 or NFPA211.

All electrical wiring must be in accordance with the requirements of the authority having jurisdiction or, in absence of such requirements, with the National Electric Code, NFPA 70.

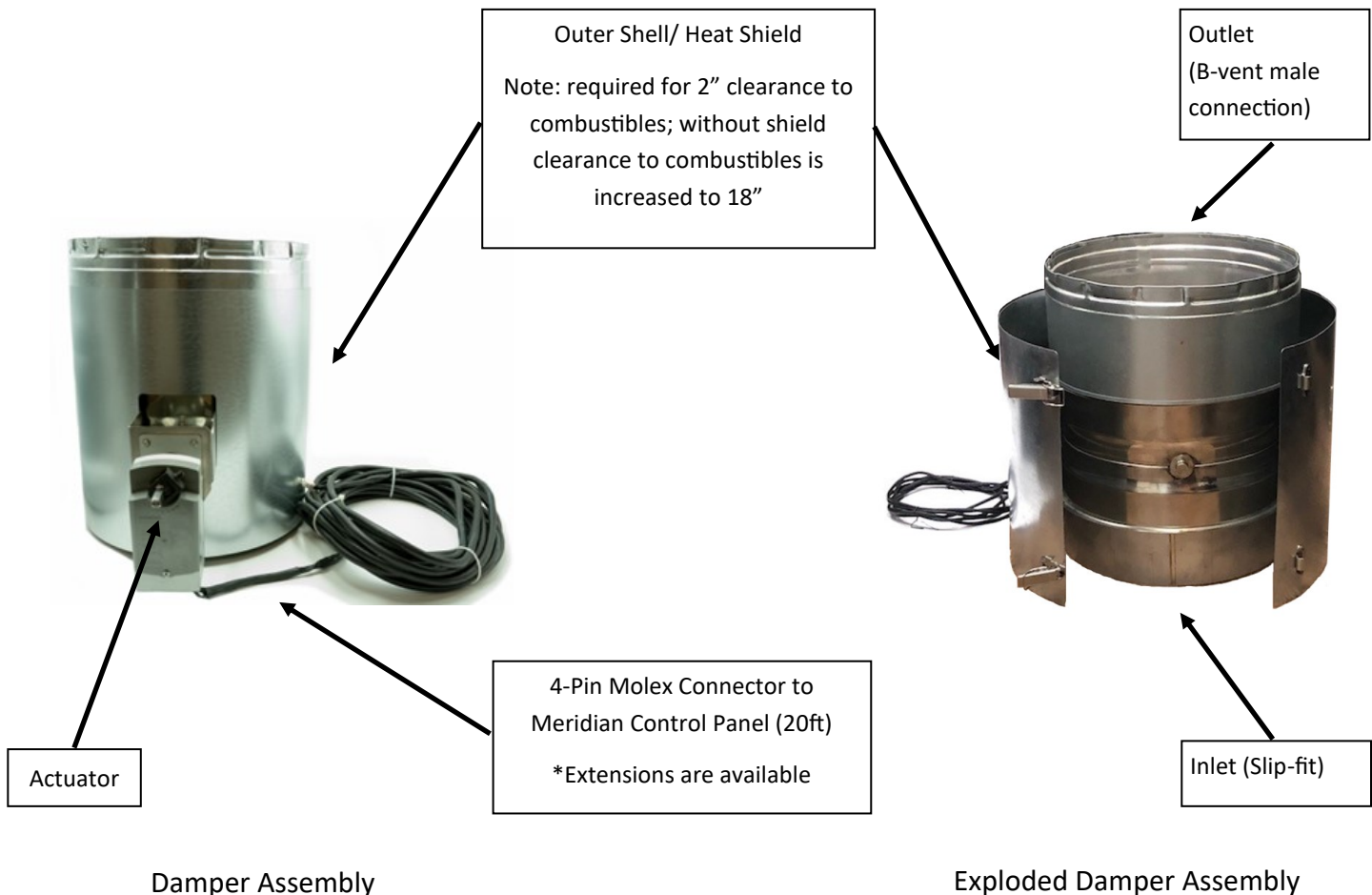

FIGURE 23

X-VENTISO-Meridian-350 Fan and Adapter - General Information

The X-VENTISO-Meridian-350 Fan (**Figure 24**) is a high temperature exhaust fan that maintains the necessary draft for the Maximus Linear series. It has been rated for all high temperature chimney, flue, and grease duct applications up to 2100 CFM, but has specific Molex connections for usage with the Meridian Control Panel. This fan is UL and ULC listed for all gas, liquid, or solid fuel burning fireplaces, ovens, cooking appliances, and domestic heating appliances, up to 1000°F continuous, 1400°F abnormal. The housing and impeller are constructed of 316L stainless steel, which helps prevent corrosion from the elements. The tool-less clamp and hinge provides easy access to the impeller for routine maintenance and cleaning.

The X-VENTISO-Meridian-350 Fan is listed to the following standards: UL378 Standard for Draft Equipment, rated up to 1,000°F continuous, 1400°F abnormal operation; UL705 Standard for Power Ventilators, UL762 Standard for Power Roof Ventilators for restaurant exhaust appliances rated up to 1,400°F abnormal operation CAN3-B255-M81 Standard or Mechanical Flue Gas Exhausters, rated up to 1,000°F continuous, 1,400°F abnormal operation ULCS645 Standard for power roof ventilators for commercial and institutional kitchen exhaust systems. Please follow all code requirements according to NFPA54 & NFPA211. For solid fuel cooking appliances, follow NFPA96. The installation must follow national codes and standards. The chimney fan must be installed at the termination of the flue gas system. The fan must be safely secured to the chimney system.

The X-VENTISO-Meridian-350 Fan uses the X-VENTISO-12” Pipe Adapter for 350 Fan (**Figure 24**) to mate the fan to 12” B-vent chimney. The adapter has a slip-fit collar that inserts into the B-vent pipe and a mounting flange that provides a stable surface for the fan. The adapter allows for the fan to be mounted to the exterior wall of the structure in horizontal termination installations.

CODE COMPLIANCE

Installations must conform to requirements of the authority having jurisdiction. Where required by the authority having jurisdiction, the installation must also conform to the Standard for Draft Equipment and The National Fuel Gas Code, ANSI Z223.1/NFPA 54.

All electrical wiring must be in accordance with the requirements of authority having jurisdiction or, in the absence of such requirements, with the National Electrical Code, NFPA70.

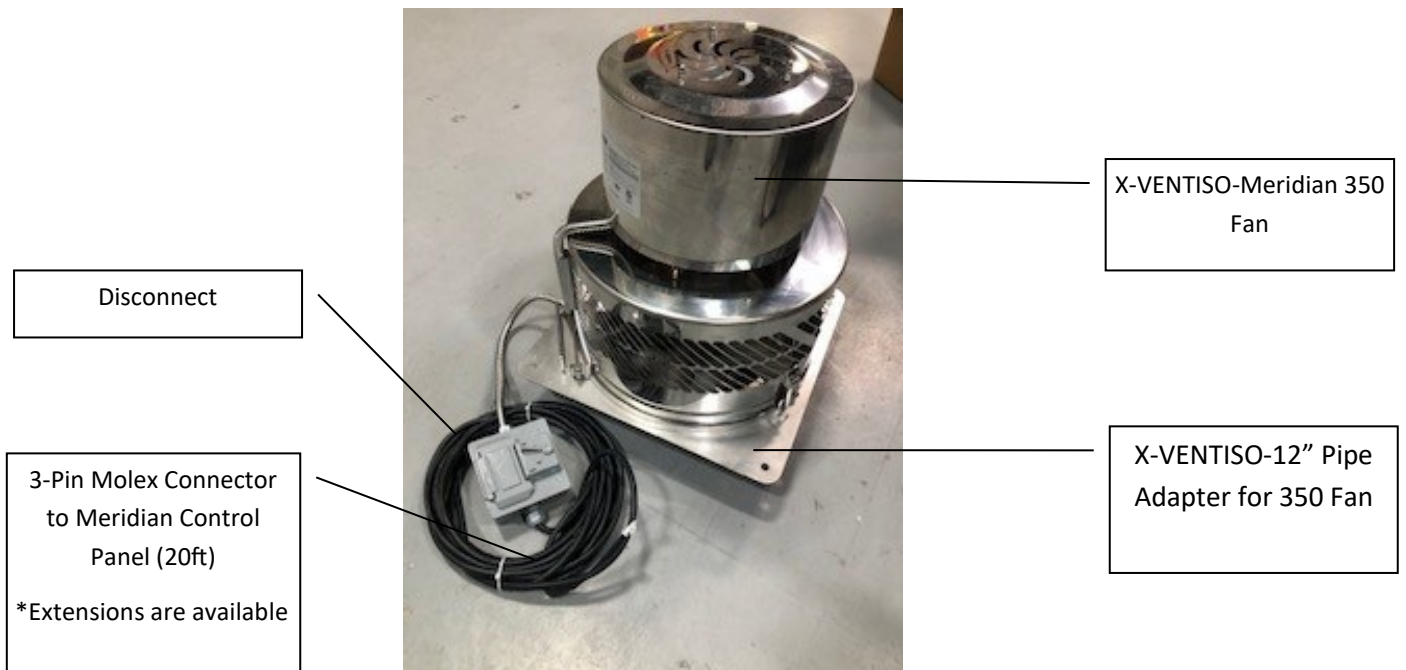

FIGURE 24

X-VENTISO-Meridian Control Panel - Installation

- 1) Determine a suitable location for installation of the Meridian Control Panel. Care should be taken to determine the best location for the Meridian control panel prior to installation. A few considerations/ requirements for locating the panel are:
 - The location must be accessible for servicing after installation.
 - When possible, a single “accessible” location is preferred for access to the Meridian control panel as well as the gas valve control box (E-VK (N/P) for the Isoflames linear burner. With mounting feet installed the Meridian Control Panel measures approximately 9-1/2” (W) x 12” (T) as shown in **(Figure 25)**. The gas valve control valve box measures approximately 12” (W) x 12” (T) x 4” (D). The gas valve control box installation will be covered in section “Gas Line & Valve Box Installation”.
 - The location of the Meridian Control Panel is dependent upon the fireplace model and must be within the values shown in **(Figure 26)**. The distances shown are as measured horizontally from the fireplace flue-outlet.
 - Location of the Meridian Control Panel must also be within 48” of the E-VK(N/P) Gas Valve Control Valve (as measured from center to center of the panel and valve enclosure) .

NOTE: the Isoflames Linear Burner’s gas valve control box location is also dependent upon the fireplace model/ burner size. It must be located within 84” of the sidewall of the firebox for the 48” and 72” Maximus Linear and within 24” for the 96” and 120” Maximus Linear **(Figure 26)**.

- Two 120 VAC / 15A outlets must be provided at the chosen location on a dedicated circuit; one for the Meridian Control Panel, the other for the Gas Valve Control Box . These outlets must be within the extent of the 72” power supply cables of the Meridian Control Panel and the E-VK(N/P) Gas Valve Control assembly **(Figure 26)**.

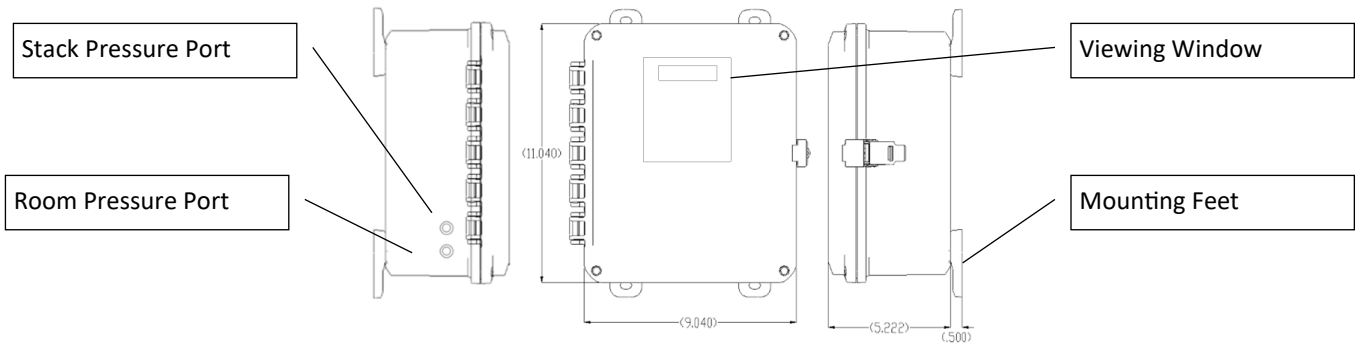

FIGURE 25

* Maximum values as shown are derived from length of Molex connectors to the gas valve control assembly.

** Outlet locations must be within the extents of the 72" power supply cables of the Meridian Control Panel and the E-VK(N/P) Gas Valve/ Control Assembly

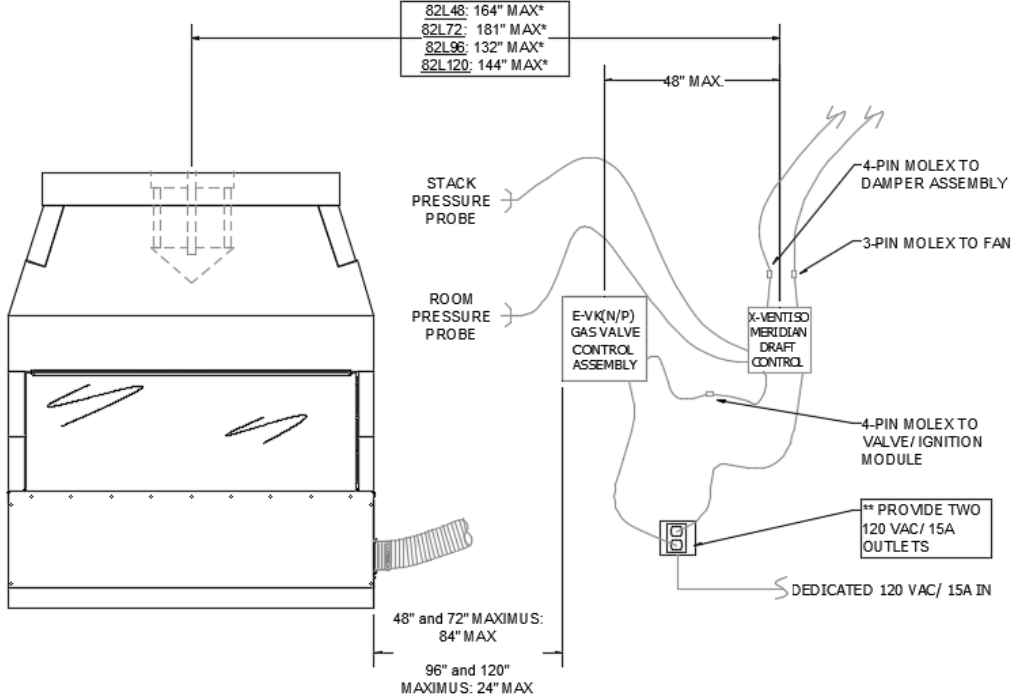

FIGURE 26

X-VENTISO-Meridian Control Panel - Installation

- 2) After deciding upon a suitable location for installation of the Meridian Control Panel and ensuring that two 120 VAC/15A outlets have been installed, install the four mounting feet on the back of the Meridian Control Panel enclosure. Secure the panel to a vertical wall or structure able to support the Meridian Control Panel using 4 suitable fasteners for the weight and support material.
- 3) Connect the top port of the Meridian Control Panel’s pressure ports with the supplied tubing to the “Stack Pressure” vent probe (**Figure 26, 27 & 29**). This will be connected to the chimney at a location 12” above the anchor plate.
- 4) Connect the lower port of the Meridian Control Panel’s pressure ports with the supplied tubing to the “Room Pressure” vent probe (**Figure 26, 28 & 29**). The other end will be connected in a suitable location in the room in which the fireplace is installed. This location must be in the same pressure zone as the fireplace opening, and within reach of the supplied tubing’s connection to the Meridian Control Panel. The tubing measures 20ft.

NOTE: the remaining Molex connections will be made after the installation of the B-vent chimney system, mechanical draft components, and the Isoflames Linear burner. Ensure all connectors are protected and kept clean and clear of all construction debris until they are connected to their respective components.

Refer to (**Figure 29**) for identification and location of the unique Molex connections on the Meridian Control Panel.

Stack Pressure Vent Probe and Tubing



FIGURE 27

Room Pressure Probe/ Cover Plate, and Tubing Kit



FIGURE 28



FIGURE 29

Selecting Horizontal or Vertical Venting System

With the Maximus Linear fireplace and Meridian Control Panel installed; identify the exterior termination type and location and determine vent routing. Care should be taken to identify obstacles that will require offsets, proper floor and wall protection at flue penetrations, and exterior termination locations/ clearances. The following sections describe the installation of both vertically (roof) and horizontally (exterior wall) terminating vent applications. Refer to the sections relating to your installation.

IMPORTANT: Vertically terminating chimneys may have the damper mounted either “inline” (located in the middle of the flue run) or at the termination of the flue run.

IMPORTANT: Horizontally terminating chimneys must utilize the damper “inline”.

Vent Installation: General

NOTE: The configuration of your venting system may contain a combination of vertical and horizontal paths. Ensure that proper floor/ wall protection is used at all penetrations and that clearances to combustibles are maintained at all times.

1. **Mount Anchor Plate with Down Draft Diverter:** Chimneys for all Maximus Linear fireplace systems must begin with an Anchor Plate with Down Draft Diverter. It is important that the surface of the Isokern chimney has a level surface on which to attach the Anchor Plate. If the top of the Isokern does not have a level surface, then it will need to be modified accordingly.
- 2) Center the Isowool blanket over Isokern Top Plate’s outlet and trace the outlet’s outline with a pen or marker. Cut a hole in the blanket along this outline to match the hole in the Isokern top plate. Center the cut Isowool blanket over the Isokern Top Plate flue opening, then center Anchor Plate over the Isowool blanket (**Figure 30**).
- 3) Secure the Anchor Plate with four (4) masonry anchors.
- 4) Starting at the anchor plate, attach the first section of B-Vent Pipe. A minimum of 12” of straight pipe will be required before any offset. The B-Vent sections and components use the Metal-Fab positive twist-lock for interconnections. Align the ends of the vent, push together then twist section to lock in place (**Figure 31**).

NOTE: No additional fasteners are required to assure a safe installation. It is acceptable to apply screws at the joints if local code requires, or at the installing contractor’s option, provided that the screws do not penetrate the flue inner wall.

- 5) Depending on the termination requirement of the installation, proceed to either “Vent Installation: Vertical Termination Systems” or Vent Installation: Horizontal Termination Systems”

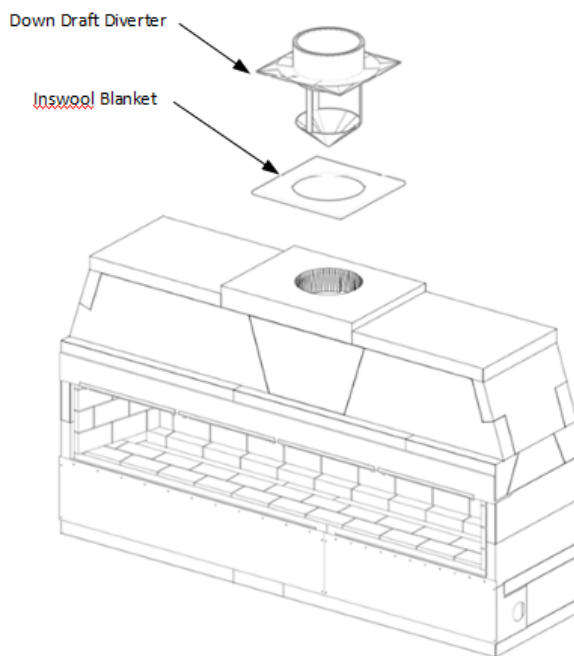

FIGURE 30

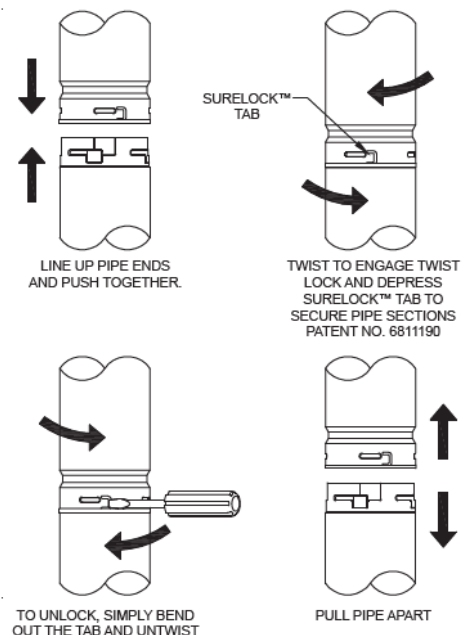

FIGURE 31

Vent Installation: Vertical Termination Systems

This section covers the installation of vertical termination systems. Vertically terminating chimneys may have the damper mounted either “inline” (located in the middle of the flue run) or at the termination of the flue run. If your installation utilizes a horizontal termination, proceed to section “Vent Installation: Horizontal Termination System”.

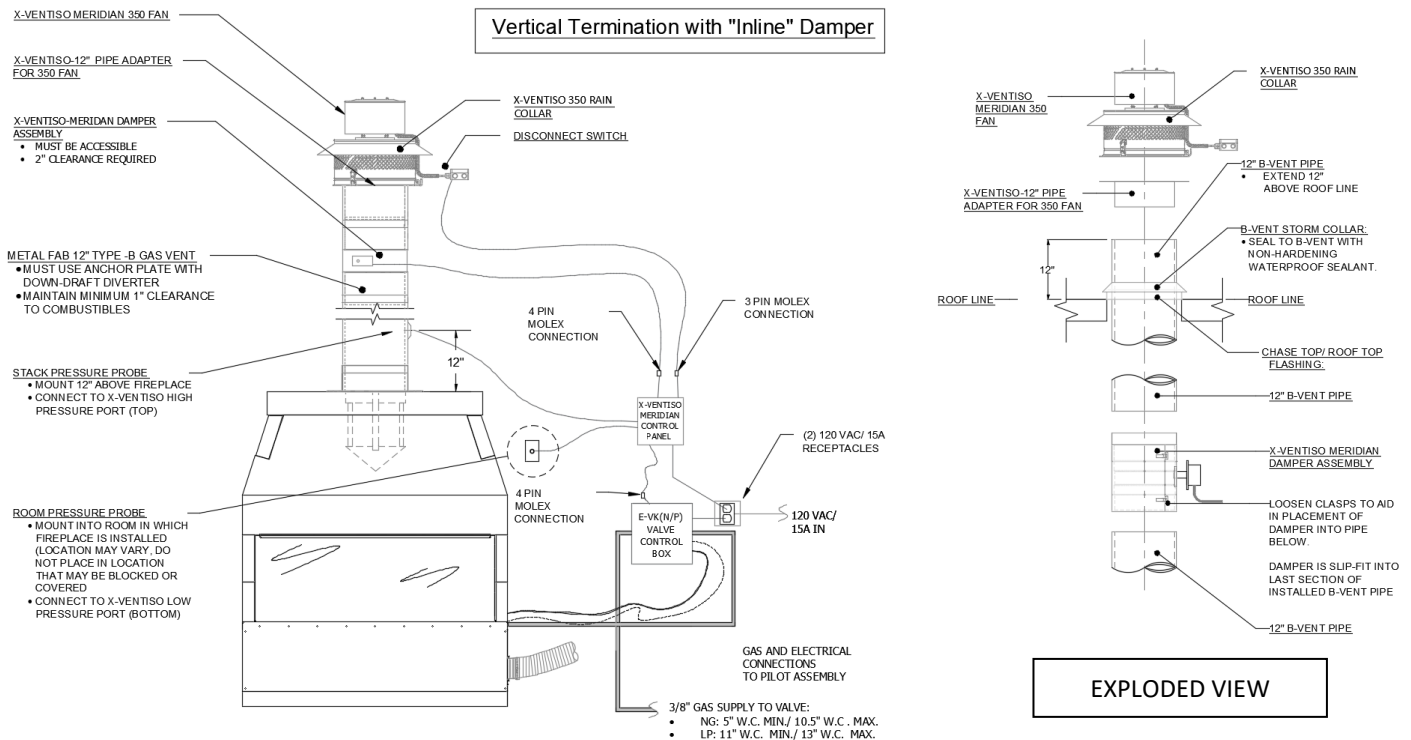

FIGURE 32

Vertical Termination with “Inline” Damper

- 1) After mounting of the Anchor Plate and at least 12” of vertical pipe; continue installation of 12” B-vent pipe to an accessible location in the run for installation of the damper.
- IMPORTANT:** XVENTISO-Meridian Damper Assembly must be installed with the provided outer shell to maintain its 2” clearance to combustibles. Without the shell in place, the damper assembly requires an 18” clearance to combustibles. Failure to properly meet these clearances may result in potential fire hazard.
- 2) Unclasp the two clasps on the outer-shell of the damper assembly. This will help to properly position and aid in inserting the damper into place.
- 3) Insert the damper into the last section of B-vent pipe. Ensure the damper is fully inserted, and the assembly is flush and level. The outer shell of the damper assembly should cover the intersection of damper assembly and the last section of B-vent pipe.
- 4) Close the clasps on the outer shell of the damper assembly to secure it into position.
- 5) Support the damper with noncombustible material (plumbers strap) to ensure there can be no movement.
- 6) Run the damper cable to the Meridian Control Panel and connect to its unique mating 4 pin Molex connector. Extensions are available by special order if required.
- 7) Continue the installation of the chimney by installing sections of B-vent pipe to the location of termination. Ensure the last section of B-vent Chimney extends at least 12” above the roof line.
- 8) Install the XVENTISO-12” Pipe Adapter for 350 Fan at the termination by inserting into last section of B-vent pipe.
- 9) Mount the X-VENTISO-Meridian 350 Fan to the adapter plate with the supplied hardware. Mount the disconnect box in an accessible location. Conduit should always be installed in a downward orientation.
- 10) Run the fan cable to the Meridian Control Panel and connect to its unique mating 3 pin Molex connector. Extensions are available by special order if required.

Reference (**Figure 32**) for component placement in a typical vertically terminating system where damper is installed “inline”.

Vent Installation: Vertical Termination Systems

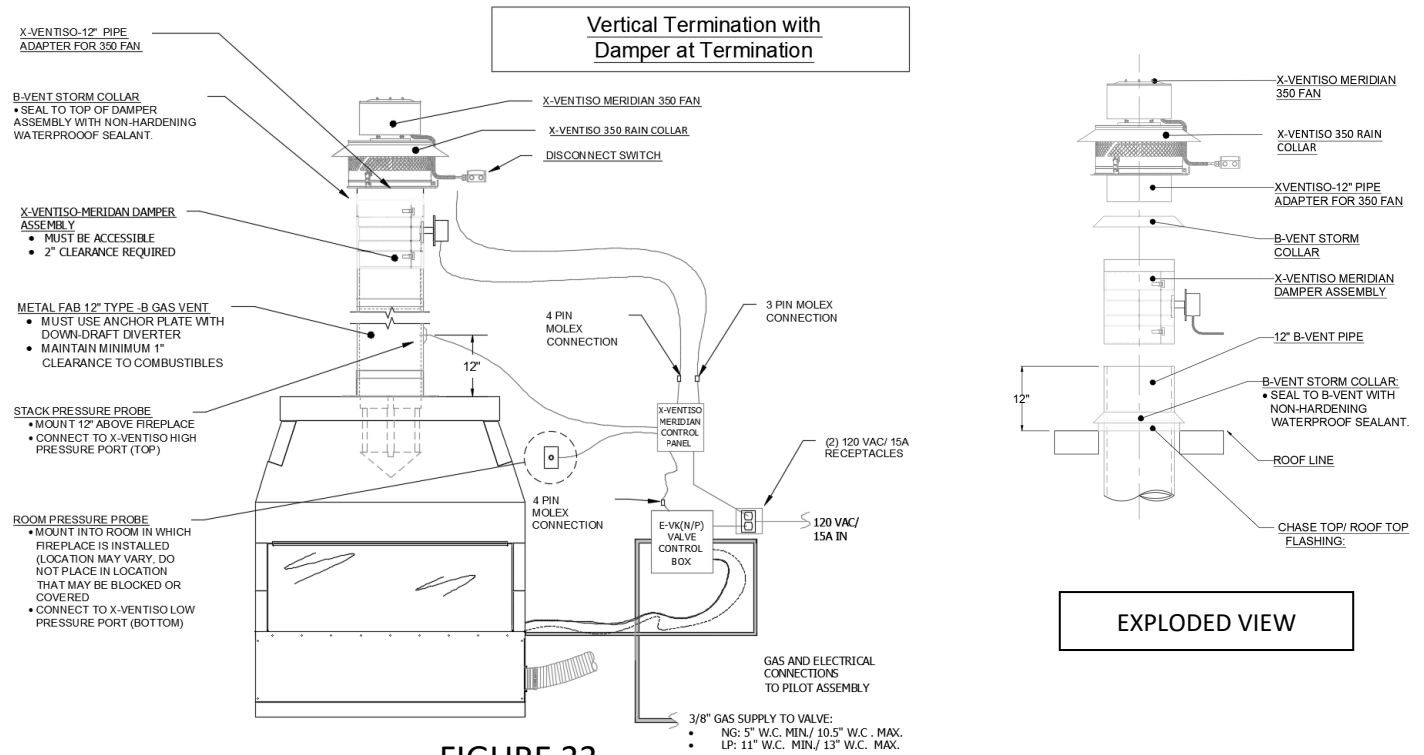

FIGURE 33

Vertical Termination with Damper at Termination

1) After mounting of the Anchor Plate and at least 12" of vertical pipe; continue the installation of the chimney by installing sections of 12" B-vent pipe up to the location of termination. The damper will be installed at this location. Ensure the last section of B-vent Chimney extends at least 12" above the roof line.

IMPORTANT: XVENTISO-Meridian Damper Assembly must be installed with the provided outer shell to maintain its 2" clearance to combustibles. Without the shell in place, the damper assembly requires an 18" clearance to combustibles. Failure to properly meet these clearances may result in potential fire hazard.

- 2) Unclasp the two clasps on the outer-shell of the damper assembly. This will help to properly position and aid in inserting the damper into place.
- 3) Insert the damper into the last section of B-vent pipe. Ensure the damper is fully inserted, and the assembly is flush and level. The outer shell of the damper assembly should cover the intersection of the damper assembly and the last section of B-vent pipe below.
- 4) Close the clasps on the outer shell of the damper assembly to secure it into position.
- 5) Run the damper cable to the Meridian Control Panel and connect to its unique mating 4 pin Molex connector. Extensions are available by special order if required.
- 6) Attach a Storm Collar around the upper part of the damper assembly at a location slightly above and covering the outer shell. Seal around the storm collar with a non-hardening waterproof sealant.
- 7) Install the XVENTISO-Meridian 12" Pipe Adapter at the termination by inserting into the damper assembly.
- 8) Mount the XVENTISO-Meridian 350 Fan to the adapter plate with the supplied hardware. Mount the disconnect box in an accessible location. Conduit should always be installed in a downward orientation.
- 9) Run the fan cable to the Meridian Control Panel and connect to its unique mating 3 pin Molex connector. Extensions are available by special order if required.

Reference (**Figure 33**) for component placement in a typical vertical termination system where damper is installed at termination.

Vent Installation: Horizontal Termination Systems

- 1) After mounting the Anchor Plate with Down-Draft Diverter and at least one 12” section of B-vent pipe, continue the installation of the chimney by installing sections of 12” B-vent pipe to the location of the XVENTISO-Meridian Damper Assembly. The damper may be installed at any accessible location in the run, but not at horizontal termination.

IMPORTANT: For horizontal and lateral runs, it is recommended that support be used every 5 feet (1524 mm), and that each individual pipe section is individually supported. Plumber’s straps are commonly used. They should be positioned to maintain 1 inch (25.4 mm) clearance to combustibles.

IMPORTANT: If the installation contains a horizontal run that passes through any combustible wall, a wall thimble is to be utilized at each wall penetration.

NOTE: Ensure that proper floor/ wall protection is used at all penetrations, that clearances to combustibles are maintained at all times, and that all sections of pipe are properly supported.

NOTE: Horizontal runs of pipe should be sloped upwards towards the termination at a minimum of 1/4” rise per foot.

- 2) Unclasp the two clasps on the outer-shell of the damper assembly. This will help to properly position and aid in inserting the damper into place.
- 3) Insert the damper into the last section of B-vent pipe prior to desired damper location. Ensure the damper is fully inserted, and the assembly is flush and level. The outer shell of the damper assembly should cover the intersection of the damper assembly and the last section of B-vent pipe.
- 4) Close the clasps on the outer shell of the damper assembly to secure it into position.
- 5) Support the damper with noncombustible material (plumbers strap) to ensure there can be no movement.

IMPORTANT: Damper must be installed with the provided outer shell to maintain its 2” clearance to combustibles. Without the shell in place, the damper assembly requires an 18” clearance to combustibles. Failure to properly meet these clearances may result in potential fire hazard.

- 6) Run the damper cable to the Meridian Control Panel and connect to its unique mating 4 pin Molex connector. Extensions are available by special order if required.
- 7) Continue the installation of the chimney by installing sections of 12” B-vent pipe to the location of termination at exterior wall.
- 8) Install the XVENTISO-12” Pipe Adapter for 350 Fan at the termination by inserting into the last section of B-vent pipe. The fan adapter must be anchored directly into wall framing. Anchorage must be able to support a minimum of 150 lbs.

IMPORTANT: Ensure that all wall penetrations are properly flashed to prevent water intrusion and that the fan adapter is sealed to the structure using non-hardening waterproof sealant.

- 9) Mount the XVENTISO-Meridian 350 Fan to the adapter plate with the supplied hardware. Mount the disconnect box in an accessible location. Fan must be oriented so that conduit is installed in a downward orientation.
- 10) Run the fan cable to the Meridian Control Panel and connect to its unique mating 3 pin Molex connector. Extensions are available by special order if required.

Reference (**Figure 34 and 35**) for component placement in a typical horizontal termination system .

Vent Installation: Stack Pressure and Room Pressure Probe

The vent installation of the XVENTISO-Meridian Max Linear Fan system is not complete until installation of the required pressure probes. The Stack probe installation requires access to the vent pipe, therefore should be done before application of any wall sheathing/ finish materials. The Room Pressure probe is required to sense the pressure inside the envelope of the room in which the fireplace is installed. It is important to plan and coordinate this requirement prior to construction of the wall sheathing/ finish materials to ensure the probe is installed in the desired location.

Stack Pressure Probe Installation (Figure 36):

- 1) Drill a $\varnothing 3/8$ " hole into B-vent pipe at a location 12" above the fireplace flue outlet.
- 2) Route the Stack Pressure Probe and tubing that is connected to the upper pressure port of the Meridian Control Panel to this location (If this was not connected previously, connect to upper port at this time)
- 3) Insert the Stack Pressure Probe into hole drilled in the pipe, and secure with provided fasteners.

Room Pressure Probe/ Cover Plate Installation (Figure 36):

- 1) Determine location for Room Pressure Sensor in room in which fireplace is installed. Location must be in the same pressure zone as the fireplace opening, and within reach of the supplied tubing's connection to the Meridian Control Panel. The tubing measures 20ft. A location should be selected that will ensure sensor is not blocked/ covered after installation. Do not locate sensor in close proximity to exterior doors, opening windows, supply air diffusers, or other know air disturbances
- 2) Drill a hole in finished wall surface that is large enough to allow passage of tubing.
- 3) Pass tubing through hole and secure tubing onto port on rear of Cover Plate.
- 4) Affix Cover Plate to wall with provided hardware
- 5) Verify tubing is securely connected at Room Pressure Probe and the Room Pressure Port (Lower/ Low Pressure) of the Meridian Control Panel.

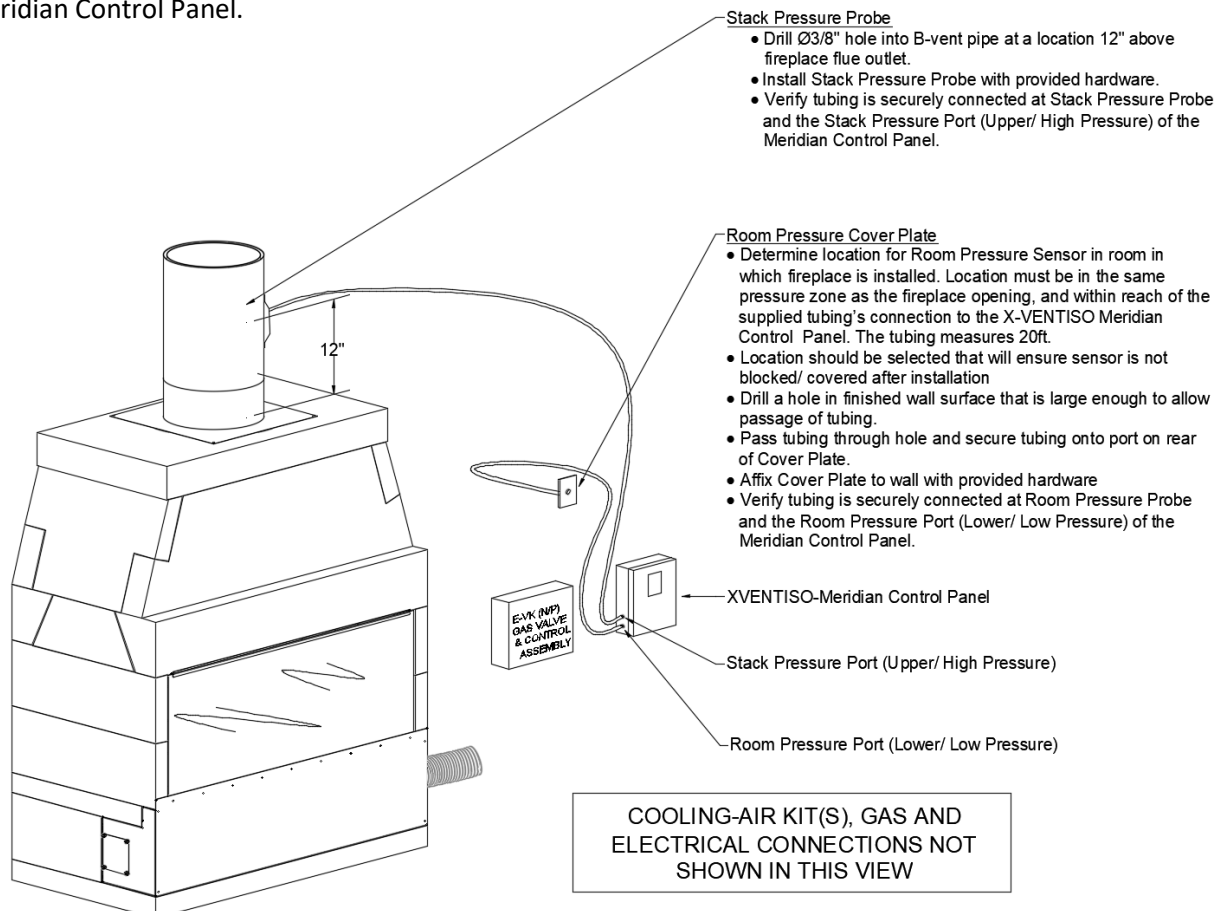

FIGURE 36

Firebrick Installation - General Information

Earthcore/ Isokern requires the Maximus Linear Series fireboxes be lined with a minimum one and one-eighth (1-1/8") thick firebrick ("Split") for the sidewalls and 2-1/4" thick firebrick ("Full") on the floor. Thicker firebrick may be used as an option. The pattern for the firebrick lining is an owner option. The ISOSET mortar by Earthcore is to be used when lining the Isokern Fireplace.

ISOSET FIREBRICK MORTAR APPLICATION:

- Add .75 quarts of water per 10 lbs. of dry product until completely blended.
- Only mix what can be utilized within 15 minutes.
- Do not re-temper (the addition of water after the chemical reaction has begun).
- The use of warm water will accelerate setup.
- Joint thickness should be thin (1/4" - 3/8")
- Complete set time is between 48 and 72 hours.
- For best results, please allow 28 days before heat is applied.
- Approximately 35 to 40 lbs. of prepared mortar will lay up one hundred 9" x 4-1/2" x 2-1/2" straights.

IMPORTANT!!!: DO NOT add additives, such as fire-clay, sand, cement, or other accelerators.

These instructions may vary because of different climates and conditions. The use of good masonry practices for your area should also be considered.

FOR BEST RESULTS:

- Wet mop the inside of the fireplace with a damp sponge to remove dust and loose particles from the interior before installing firebrick. Keep the fireplace damp while installing firebrick
- After "wet sponging interior" of firebox, apply a 1/4" notch bed joint on rear, sides, and floor.
- Dip each firebrick in a pale of water before applying mortar to one side for adherence to firebox.
- Facing joint dimensions of 1/4" to 3/8" in the brick work is recommended and has the best appearance. Other face joint dimensions are acceptable, however smaller joints may not leave room for heat expansion of firebrick.

NOTE: Earthcore makes no claims as to the performance of firebrick or firebrick mortar(s). It is typical for heat stress cracks to appear in the firebrick in fireplaces.

Firebrick Installation - Maximus Linear with Glass-Front Fireplace

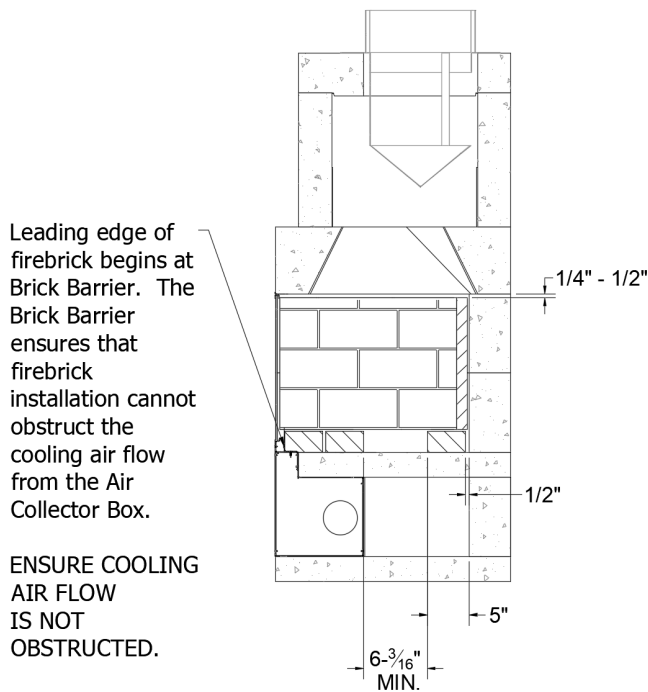

FIGURE 37

- 1) Starting approximately 1/2" from the rear of the firebox, lay one course of "full" sized firebrick on floor. Ensure a gap of approximately 1/2" is kept between firebrick and sidewall to allow for expansion.
- 2) Lay two courses of "full" sized firebrick so that the leading edge of the coursing begins at the Brick Barrier that is affixed to the Air Collector Box (s). Ensure a gap of approximately 1/2" is kept between firebrick and sidewall to allow for expansion.

IMPORTANT: The Brick Barrier prevents installation of firebrick in a manner that may block the cooling air vents. **DO NOT BLOCK THE COOLING AIR VENTS.**

- 3) Apply "split" firebrick to the rear wall of the unit. Ensure approximately 1/2" gap is kept between firebrick and sidewall, as well as an 1/4" gap is kept between firebrick and damper beam assembly to allow for expansion.
- 4) Starting at the front edge of the unit's sidewall, apply "split" firebrick to the side wall of the unit. Ensure approximately 1/4" gap is kept between firebrick and damper beam/damper block assembly to allow for expansion.
- 5) Repeat on opposite side wall.

IMPORTANT:

Ensure that the required holes for the Isoflames Linear burner's 3/8" gas supply line and pilot assembly gas and electrical connections are drilled prior to firebrick installation.

DO NOT COVER THESE AREAS WITH FIREBRICK!

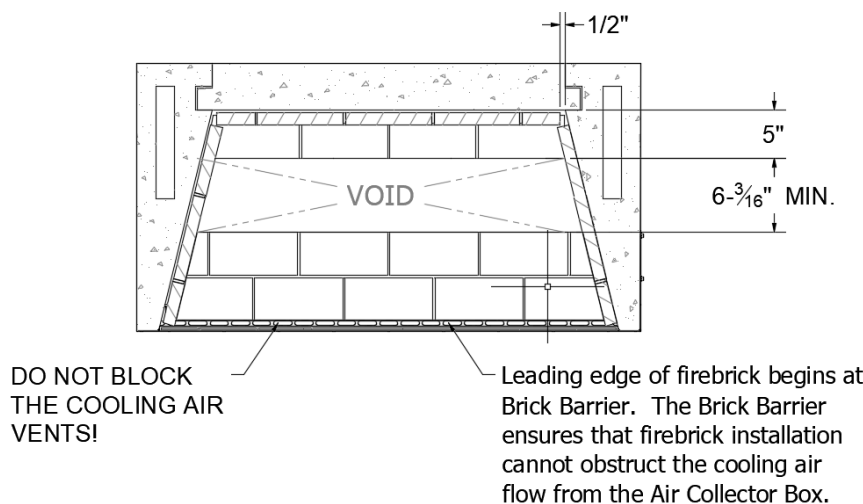

FIGURE 38

NOTE: Gas and electrical connections may be brought through the rear wall of the unit and into the area of the firebrick cavity. A gap will need to be left in the firebrick extending from the cavity to the rear wall of the unit for passage of the 3/8" gas line, pilot tube, and electrical connections. Ensure all holes are filled with mortar after installation.

Flush Wall Finish Detail

Maximus Linear units shall be installed so that the rough front face of the Isokern firebox is flush to the outside edges (room side) of the rough framing members that create the room wall's finish (**Figure 39**).

IMPORTANT!!!: Do not build a combustible frame wall in front of the Maximus Linear Fireboxes (**Figure 40**).

CLEARANCE TO DRYWALL:

Drywall can be placed directly in contact with the front of the Maximus Linear smoke dome. Drywall can be hung on the framing members and pass across the face of the Maximus Linear smoke dome and in contact with it.

This sheathing can be installed at zero-clearance to the firebox opening on the Maximus Linear with Glass Front.

IMPORTANT: Any gaps or voids that result from the installation of material installed against the fireplace must be filled with Earthcore adhesive

IMPORTANT: Any sheathing or finish material that is installed must not cover the glass panels. The glass panels must remain removable for cleaning and servicing of the fireplace and burner.

WARNING!!!: Avoid false chimneys. Failure to seal any gaps between the front face(s) of the firebox and the back of the noncombustible finished facing material will create what is known as a “false chimney” or “secondary chimney”. A “false chimney”, in this case is the narrow gap between the back of the noncombustible facing material at the top of the firebox opening and the rough front of the Maximus Linear damper assembly/ smoke dome. If left unfilled this gap creates a “false- chimney” which can cause a fire hazard by drawing considerable heat out of the firebox and into the space behind the noncombustible finish facing and then up into the wall cavity behind the drywall or other sheathing material that houses the Isokern fireplace.

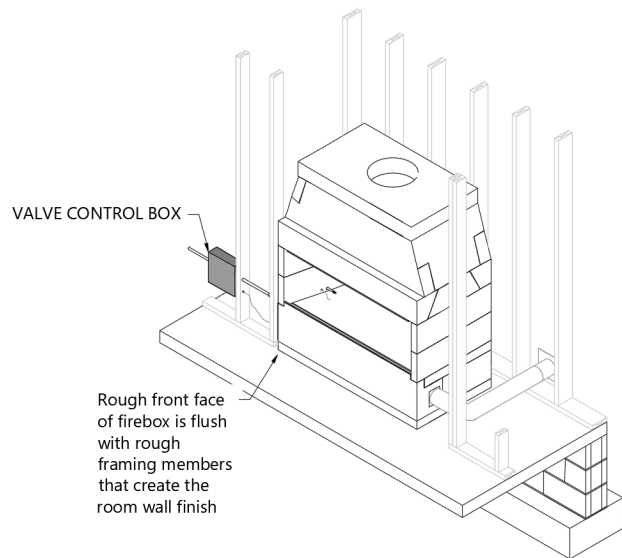

FIGURE 39

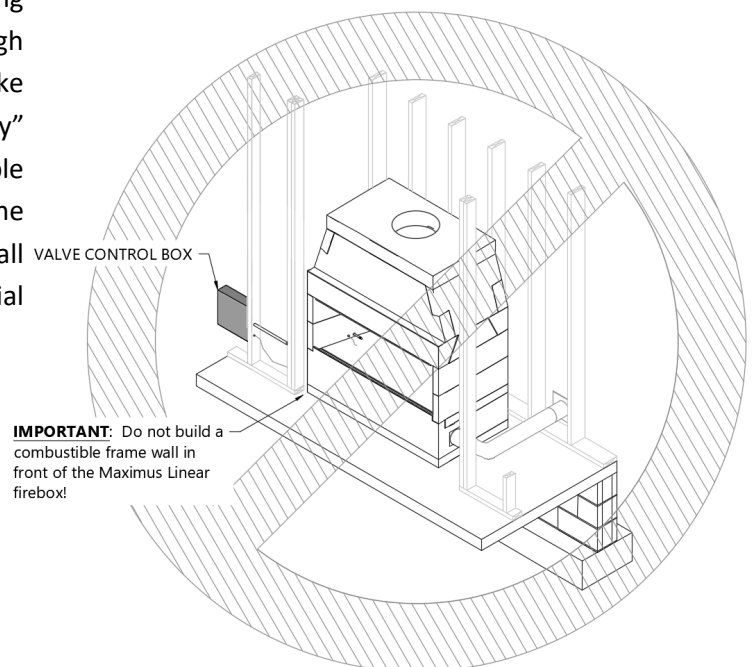

FIGURE 40

Clearance to Combustible Trim

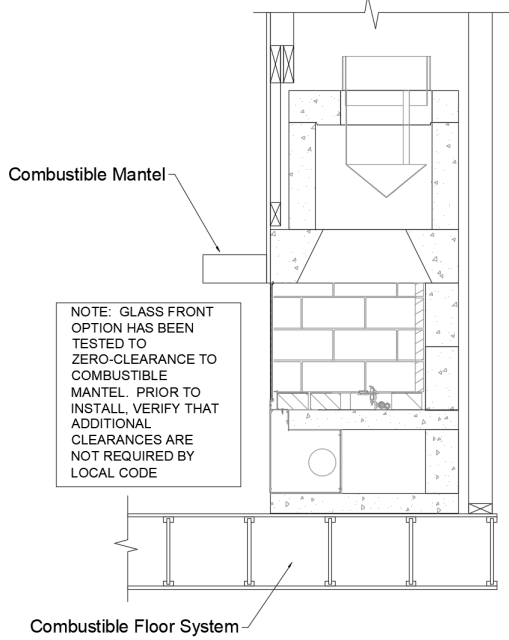

FIGURE 41

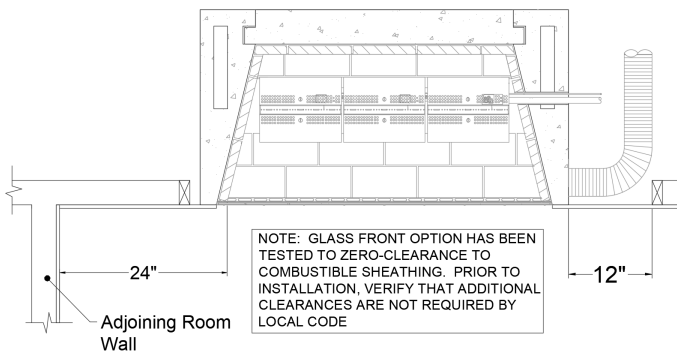

FIGURE 42

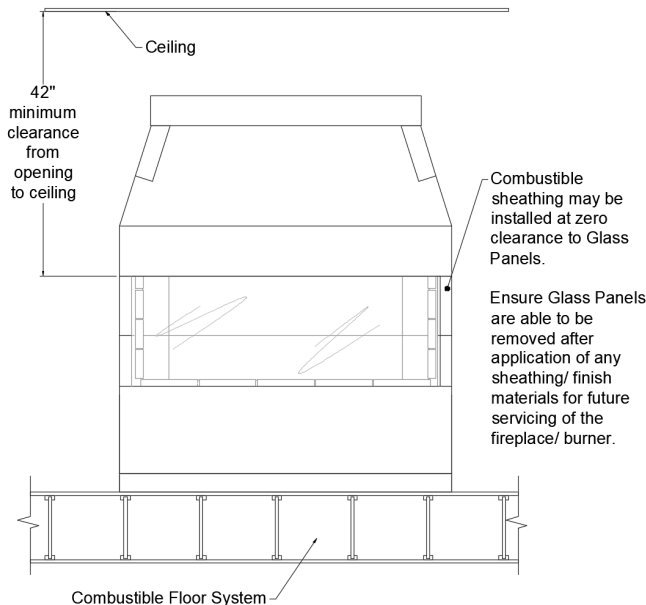

FIGURE 43

NOTE: “Clearance to Combustible Trim” are those distances required to ensure that a fireplace mantel or facing will not catch fire. In most cases the distances should also be adequate to prevent any discoloration or warping due to heat. However, each installation presents a unique and completely different set of circumstances involving many variables.

These variables include paint or finish composition, previous exposure to heat, methods and quality of construction, air flow patterns, etc. Because of these variables, the manufacturer does not guarantee that heat-warping or discoloration will never occur.

MANTEL AND MANTEL SHELF CLEARANCES:

Maximus Linear with Glass Fronts units are designed to be installed so that the rough front face(s) of the Isokern firebox and sits flush with the face of the rough framing members that create the room wall finish.

The Maximus Linear with Glass Front has been tested to zero-clearance to combustible mantel and sheathing. The zero-clearance rating requires the glass panels to be installed during fireplace operation. Do not operate with the glass panels removed. Prior to installation, verify that additional clearances are not required by local code (Figure 55).

ADJOINING WALLS:

It is recommended that adjoining room walls to the Isokern fireplace installation not be closer than twenty-four inches (24”) to the finished fireplace opening (Figure 42).

CEILINGS:

The minimum clearance from the top of the fireplace opening to a ceiling is forty-two inches (42”) (Figure 43).

Isoflames Linear Burner - Safety Instructions

WARNING!!!: This appliance assembly contains burner orifices specifically for the input gas specified on the burner and box, as well as the BTU rating specified in this manual. Modifying or failure to use the factory orifice may cause property damage, personal injury, or loss of life.

Read these instructions completely before installing and using ISOFLAMES Linear Burner.

- 1) This Maximus Linear Series fireplaces must utilize the Isoflames Linear Burner that is specified for the particular fireplace model.
- 2) The Maximus Linear Series fireplaces utilize a mechanical draft system that interlocks with the Isoflames Linear burner to ensure burner operation is only possible when the mechanical draft system is energized, and safe operation is proved by the control. This ensures all carbon monoxide and other flue gases will be expelled through chimney system.
- 3) Solid fuels shall not be burned in the Maximus Linear Series fireplaces, or any fireplace where a decorative appliance has been installed.
- 4) The minimum inlet supply pressure for the purpose of input adjustment is 5.0 inches (natural gas) 11.0 inches (propane) in water column. The maximum inlet supply pressure is 10.5 inches (natural gas) 13.0 inches (propane) in water
- 5) Gas type will be indicated on the burner rating plate. Do not use a natural gas burner with propane or a propane burner with natural gas. Appliance is not convertible to use other gases.
- 6) The installation, provisions for combustion, and ventilation air must conform to the National Fuel Gas Code, ANSI Z223.1/ NFPA 54, or the Natural Gas and Propane Installation code, CSA B149.1.
- 7) The appliance and its main gas valve must be disconnected from the gas supply piping system during any pressure testing of that system at test pressures in excess of 1/2 psi (3.5 kPa). The appliance must be isolated from the gas piping system by closing its equipment shutoff valve during any pressure testing of the supply piping system at test pressures equal to or less than 1/2 psi (3.5 kPa).
- 8) Do not use this appliance if any part has been under water. Immediately call a qualified service technician to inspect the appliance and to replace any part of the control system and any gas control which has been under water.
- 9) Periodic examination and cleaning of the venting system of the solid fuel burning fireplace, including frequency of such examination and cleaning, by a qualified agency.
- 10)The appliance area is to be clear and free from combustible materials, gasoline and or flammable vapors and liquids. For warranty to be valid gas log sets must be installed by a NFI certified or other qualified professional installer.
- 11)Always check local building codes governing fireplaces and fireplace installations. ISOFLAMES Linear Burner installation must comply with all local, regional, state, and national codes and regulations.
- 12)This appliance is only for use with the type of gas indicated on the rating plate. This appliance SHALL NOT be field converted for use with other gases with Propane (LP) or Natural Gas (NG).
- 13)This appliance shall only be installed, serviced, or inspected by qualified professional service technician.
- 14)For propane (LP) use do not place propane supply tank(s) inside any structure. Locate propane supply tank(s) outdoors.
- 15)To prevent performance problems, do not use propane fuel tank of less than 100 lbs. capacity.
- 16)This decorative gas appliance reaches high temperature. Keep children and adults away from hot surfaces to avoid burns or clothing ignition. Fireplace will remain hot for a time after shutdown. Allow surfaces to cool before touching.
- 17)Turn the appliance off and allow to cool before servicing. Always shut off any electricity and gas to the appliance while working on it. Only a qualified service person should install, service or repair this appliance. Have your appliance inspected annually by a qualified service person.

Isoflames Linear Burner - Safety Instructions

- 18) It is imperative that the unit's control areas, burners and circulation air passages be kept clean.
- 19) Keep all combustible material, gasoline, and other flammable liquids at a safe distance from the fireplace. Do not use the appliance where these items are used or stored. Decorations, clothing, and other such combustible items should not be placed on the appliance.
- 20) Do not cook food or burn paper or other object(s).
- 21) Do not use any solid fuels - wood, coal, paper, cardboard, etc. - Use only the gas type listed on the fireplace's burner rating plate.
- 22) Do not in any way obstruct the flow of combustion and ventilation air. Provide adequate clearances around air openings into the combustion chamber as well as adequate accessibility clearances for servicing and proper operation.
- 23) Never install an ISOFLAMES Linear Burner component or accessory that has visible or suspected physical damage. These items should be inspected by a qualified representative to ensure safe condition. When in doubt, consult your local supplier.
- 24) Do not alter or modify the ISOFLAMES Linear Burner or burner components under any circumstances. Modification or alteration of any sort may void manufacturer's warranty, listings, and approvals.
- 25) The ISOFLAMES Linear Burner system is not intended to heat an entire home or to be used as a primary heat source.
- 26) Children and adults should be alerted to the hazards of high surface temperature and should stay away from this appliance to avoid burns or clothing ignition.
- 27) Young children should be carefully supervised when they are in the same room as the appliance. Toddlers, young children, and others may be susceptible to accidental contact burns. A physical barrier is recommended if there are at-risk individuals in the house. To restrict access to the fireplace, install an adjustable safety gate to keep toddlers, young children and other at-risk individuals out of the room and away from hot surfaces.
- 28) Clothing or flammable material should not be placed on or near the appliance.
- 29) Due to high temperatures, the appliance should be located out of traffic and away from furniture and draperies.
- 30) Any safety screen, guard, or barrier removed for servicing an appliance must be replaced prior to operating the appliance.
- 31) Installation and repair should be done by a qualified service person. The appliance should be inspected before use and at least annually by a professional service person. More frequent cleaning may be required due to excessive lint from carpeting, bedding material, etcetera. It is imperative that control compartments, burners, and circulating air passageways of the appliance be kept clean.

Isolflames Linear Burner - Safety Instructions

WARNING!!!: This product contains or generates chemicals known to the state of California to cause cancer or birth defects or other reproductive harm.

IMPORTANT: Read this owner’s manual carefully and completely before trying to assemble, operate or service this fireplace. Improper use of this fireplace can cause serious injury or death from fire, burns, explosions and carbon monoxide poisoning.

DANGER!!!: CARBON MONOXIDE POISONING MAY LEAD TO DEATH!

Propane (LP) gas and natural gas (NG) are both colorless and odorless gases. An odor making agent is added to each of these gases to help you detect a gas leak. However, the odor added to these gases can fade and gas may be present even though no odor exists.

Carbon Monoxide Poisoning: Early signs of carbon monoxide poisoning resemble flu symptoms, including headaches, dizziness or nausea. If you have these signs the fireplace may not have been installed properly, get fresh air at once! Have the fireplace inspected and serviced by a qualified service person or your gas supplier. Some people are more affected by carbon monoxide than others. These include pregnant women, people with heart or lung diseases or anemia, people at high altitude or under the influence of alcohol. Earthcore Industries strongly recommends the use of a carbon monoxide detector/alarm device wherever gas fired appliances are in use.

All parties either involved in or associated with the installation, service and use of this fireplace must read this entire manual. Keep this manual for reference and as a guidebook to safe operation of this fireplace.

WARNING!!!: This unit is not for use with solid fuel.

Isolflames Linear Burner - Rating Plate

Natural Gas

Propane

ISOFLAMES <small>MADE IN THE USA CHESAPEAKE, VA 23323</small>		ISOFLAMES LINEAR BURNER NOT FOR USE WITH SOLID FUEL SERIAL NO: LBN000001	
GAS TYPE: NATURAL GAS MANIFOLD PRESSURE: 3.5" - 1.6" WC MINIMUM INLET GAS SUPPLY PRESSURE: 5" WC MAXIMUM INLET GAS SUPPLY PRESSURE: 10.5 WC		ANSI Z21.50-2019 • CSA 2.22-2019 Decorative Gas Appliances for Installation in Vented Fireplace	
MODEL # <input type="checkbox"/> ISO36LBN MAX BTU 54,000; MIN BTU 38,000 <input type="checkbox"/> ISO60LBN MAX BTU 90,000; MIN BTU 63,000 <input type="checkbox"/> ISO72LBN MAX BTU 108,000; MIN BTU 75,000 <input type="checkbox"/> ISO96LBN MAX BTU 110,000; MIN BTU 84,000		WARNING: Improper installation, adjustment, alteration, service, or maintenance can cause injury or property damage. Refer to the owner's information manual provided with this appliance. For assistance or additional information, consult a qualified installer, service agency, or the gas supplier	
ELECTRICAL RATING: UNIT: ELECTRONIC 1 PH 60 HZ 120 VOLTS LESS THAN 5 AMPS			
EARTHCORE INDUSTRIES, INC HEADQUARTERS 6899 PHILLIPS INDUSTRIAL BLVD JACKSONVILLE, FL 32256			

ISOFLAMES <small>MADE IN THE USA CHESAPEAKE, VA 23323</small>		ISOFLAMES LINEAR BURNER NOT FOR USE WITH SOLID FUEL SERIAL NO: LBP000001	
GAS TYPE: PROPANE (LPG) MANIFOLD PRESSURE: 10" - 6.4" WC MINIMUM INLET GAS SUPPLY PRESSURE: 11" WC MAXIMUM INLET GAS SUPPLY PRESSURE: 14" WC		ANSI Z21.50-2019 • CSA 2.22-2019 Decorative Gas Appliances for Installation in Vented Fireplace	
MODEL # <input type="checkbox"/> ISO36LBP MAX BTU 48,000; MIN BTU 36,000 <input type="checkbox"/> ISO60LBP MAX BTU 80,000; MIN BTU 60,000 <input type="checkbox"/> ISO72LBP MAX BTU 96,000; MIN BTU 72,000 <input type="checkbox"/> ISO96LBP MAX BTU 105,000; MIN BTU 87,000		WARNING: Improper installation, adjustment, alteration, service, or maintenance can cause injury or property damage. Refer to the owner's information manual provided with this appliance. For assistance or additional information, consult a qualified installer, service agency, or the gas supplier	
ELECTRICAL RATING: UNIT: ELECTRONIC 1 PH 60 HZ 120 VOLTS LESS THAN 5 AMPS			
EARTHCORE INDUSTRIES, INC HEADQUARTERS 6899 PHILLIPS INDUSTRIAL BLVD JACKSONVILLE, FL 32256			

Isoflames Linear Burner - Components List

①

NOTE: single burner segment shown

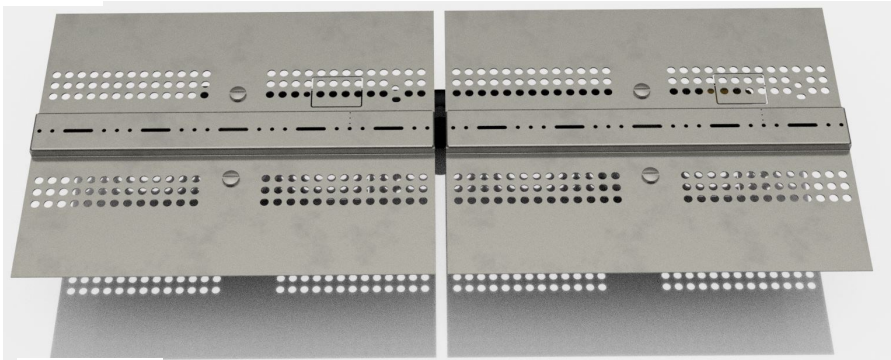

Top view

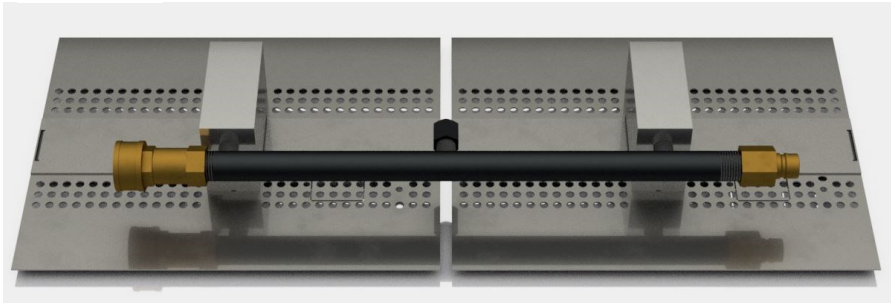

Bottom view

②



③



④

⑦



⑥



⑤



TABLE 2

Item No.	Description	Part No.	Qty
1	Main Burner Assembly (natural gas)	ISF-E-36/60/72/96N	1
	Main Burner Assembly (propane)	ISF-E-36/60/72/96P	1
2	Pilot Assembly (natural gas)	ISF-E-PAN	1
	Pilot Assembly (propane)	ISF-E-PAP	1
3	Gas Valve (natural gas)	ISF-E-GVN	1
	Gas Valve (propane)	ISF-E-GVP	1
4	Control module/remote receiver	ISF-E-ICM	1
5	Remote Transmitter	ISF-E-RM	1
6	1/2" Flared fitting female adapter	ISF-12FF-12FID	1
7	3/8" Flared fitting female adapter	ISF-12FF-38FID	1

Important: the Battery Holder/ Switch that is included with the Isoflames Linear Burner is not used for remote operation of the Maximus Linear fireplace.



Isoflames Linear Burner - Specifications

TABLE 3

Burner Specifications								
Burner Model	Minimum Fireplace Dimension (in)				BTU			
	Depth	Height	Width		Nat. Gas		L.P. Gas	
			Front	Rear	High	Low	High	Low
ISF36LB	17.5	16	48	37	54K	38K	48K	36K
ISF60LB	17.5	16	72	61	90K	63K	80K	60K
ISF72LB	17.5	16	84	73	108K	75K	96K	72K
ISF96LB	17.5	16	108	97	110K	84K	105K	87K

NOTE: Height is measured from hearth floor to bottom of lintel

Gas Line & Valve Box Installation

This appliance must be connected to the gas line in accordance with local codes and/or the National Fuel Gas Code, ANSI Z223.1. After connecting the gas line, all joints in the line and connections at the valve should be checked for leaks before final positioning of the unit. Conduct a gas leakage test of the appliance piping and control system downstream of the shutoff valve in the supply line to the appliance.

- 1) The valve control box comes with an 110" pilot assembly lead; therefore, the box must be mounted within 7' of the fireplace for burner models ISF36/60LB (N/P) and within 2' for models ISF72/96LB (N/P). **(Figure 44)**
- 2) Attach the metal enclosure to the studs using standard building materials. The metal enclosure must be mounted in a location that can be accessed in the future for additional connections & future servicing.
- 3) Installation and servicing of gas appliances and ignition systems must only be performed by qualified personnel.
- 4) Turn off gas and electricity before starting installation or service.
- 5) Make sure gas piping is pressure tested before control is connected. High pressure can damage the control causing a hazardous condition.
- 6) Make sure piping is clean and free from burrs. Apply a small amount of good quality gas-rated pipe thread compound or plumbers' tape suitable for the gas being used. Thread compound should be used sparingly on male threads only, leaving the first two threads clean.
- 7) It is recommended that a safety shut off valve is installed on either the gas in or gas outside of the valve.
- 8) It is recommended to hard pipe in the connections with unions installed inside the box.
- 9) Uncoil the pilot assembly. Be careful to not create unwanted kinks in the pilot tubing.
- 10) Feed the spade connector ends of the pilot assembly from inside the fireplace to the outside being careful not to clog the flared fitting of the pilot tube or damage the spade connectors.
- 11) Plug the spade connectors into the module according to the wiring diagram **(Figures 59 & 60)**, insert the pilot tubing into the right side of the valve and, using a wrench, tighten the nut so that the pilot tubing cannot be pulled out.
- 12) Connect the ignition control wiring harness that extends from the bottom-left of the Meridian Control Panel to the module according to wiring diagram **(Figure 29 & 46)**.

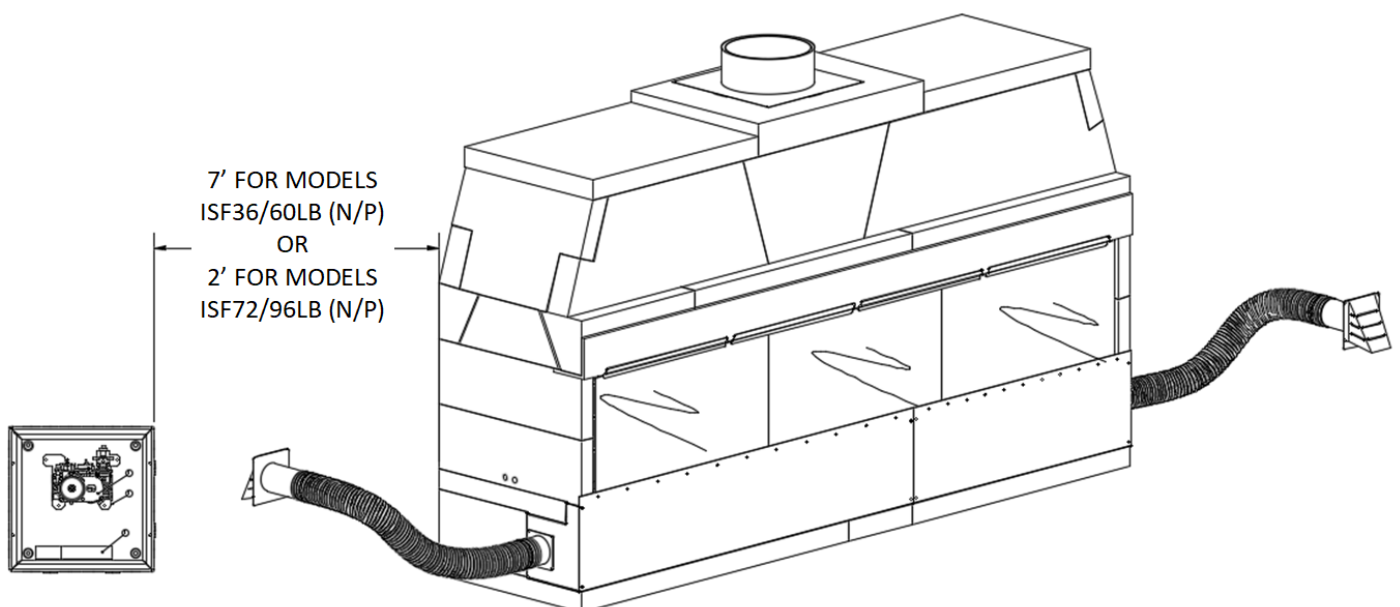

FIGURE 44

Valve Box & Burner Wiring Diagram

WARNING!!!: Do not connect 120 VAC to the control valve.

The appliance and its appliance main gas valve must be disconnected from the gas supply piping system during and pressure testing of that system at test pressures in excess of 1/2 psi (3.5 kPa).

The appliance, when installed, must be electrically grounded in accordance with local codes or in the absence of local codes, with the National Electrical Code, ANSI/NFPA 70. If not installed and maintained in accordance with the manufacturer’s instructions, this product could expose you to substances in fuel or fuel combustion which are known to the state of California to cause cancer, birth defects or other reproductive harm.

For a copy of the homeowner’s care and operation manual, go to www.earthcore.com or call 1-800-642-2920.

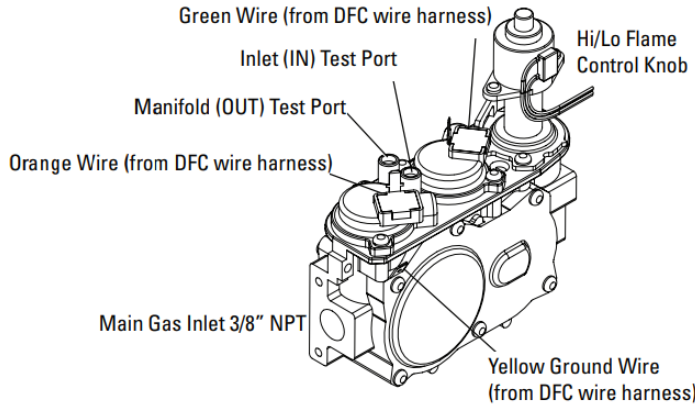

TABLE 4

Fuel Type	Inlet Pressure			Manifold Pressure	
	Desired	Minimum	Maximum	On Hi Fire	On Lo Fire
Natural Gas	7" WC	5" WC	10.5" WC	3.5" WC	1.6" WC
LP Gas	11" WC	10.5" WC	13" WC	10" WC	6.4" WC

FIGURE 45

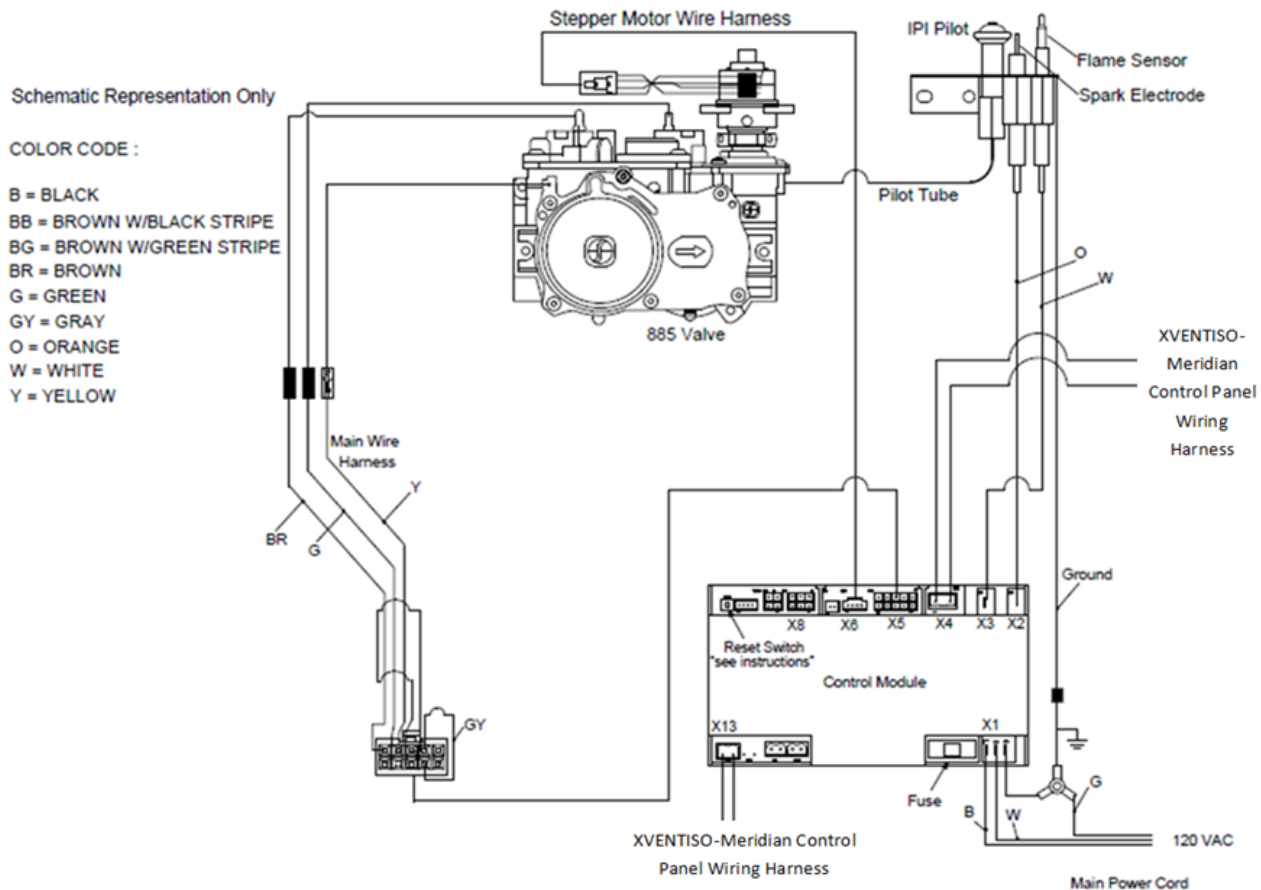

FIGURE 46

Burner Installation

IMPORTANT: Prior to installation: Shut off main gas supply to fireplace.

- 1) The ISOFLAMES Linear Burner system shall be installed by qualified professional service technician. To ensure proper performance of the appliance the owner’s installation manual must be followed carefully.
- 2) When used in the Maximus Linear Fireplace with Glass Front, the ISOFLAMES Linear Burner is designed to be recessed into the 2-1/2” deep firebrick cavity constructed as detailed in the Firebrick Installation portion of this manual (pgs. 48-49/ Figure 47 & 48).
- 3) The burner cavity must have a height of 2-1/2”, a minimum depth of approximately 7-1/4”, and the length shall extend the entire width of firebox.
- 4) The 48” and 72” Maximus Linear fireplaces (82L48 & 82L72) will require the ISF36/60LB (N/P) (respectively): Gas supply piping for these models shall terminate not less than 3” from sidewall. (Figure 49)
- 5) The 96” and 120” Maximus Linear fireplaces (82L96 & 82L120) will require the ISF72/96LB (N/P) (respectively): Gas supply stub piping for these models shall terminate within 3” from center of the cavity. (Figure 49)

TABLE 5

<u>BURNER CAVITY DIMENSIONS (in)</u>			
Burner Model	Height	Width	Length
ISF36LB	2-1/2”	6-13/16 to 7-1/4	FULL
ISF60LB	2-1/2”	6-13/16 to 7-1/4	FULL
ISF72LB	2-1/2”	6-13/16 to 7-1/4	FULL
ISF96LB	2-1/2”	6-13/16 to 7-1/4	FULL

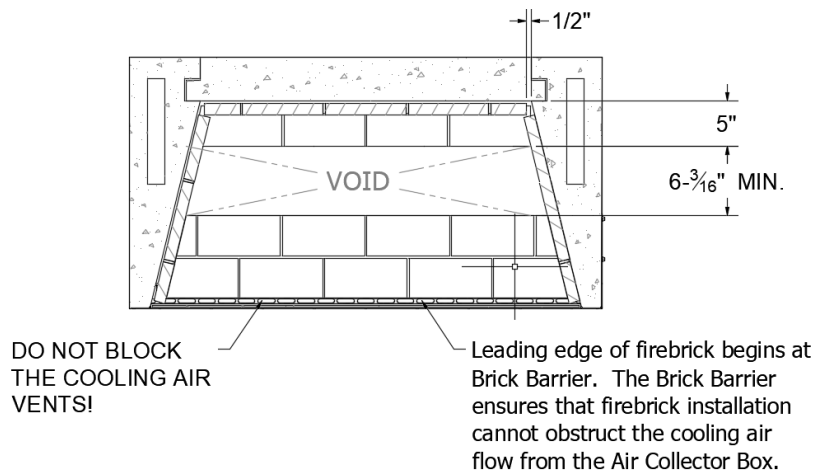

FIGURE 47

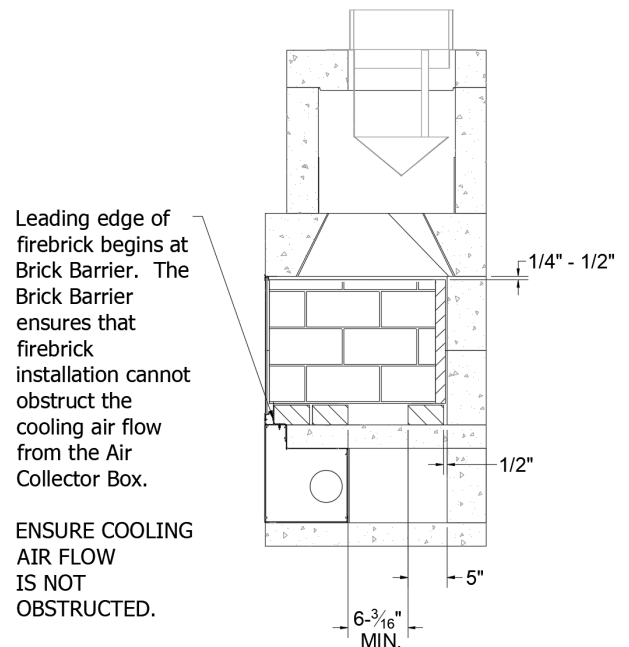

FIGURE 48

Burner Installation

- 1) Connect all burner segments according to burner model diagram Page 61-63. Make sure all connections are tightly secured.
- 2) Place burner assembly in center of fireplace floor/cavity.
- 3) Rotate the burner to position the gas inlet flared fitting to be on same side as the gas-supply stub coming from the gas valve. (Not necessary for models ISF72/96LB (N/P))
- 4) Remove the burner top closest to the gas-supply stub. Remove the top pan by unscrewing the two screws. This will allow easier access and connection of flex connector to the flared fitting. This will also be used for pilot assembly installation.
- 5) Ensure the appropriate 3/8" flared fitting is connected to the gas supply stub.
- 6) Connect the 12" flex connector to the gas inlet flared fitting on the burner assembly.
- 7) Connect the other end of 12" flex connector to the gas-supply.
- 8) Avoid creating kinks in the flex connector.
- 9) Make sure all connections are tightly secured.
- 10) Before replacing the removed burner top from **step 4**, locate the perforated rectangular section in the pan. Gently remove this section along the perforations using a screwdriver or pliers. **(Figure 50)**
- 11) Insert the pilot assembly from underneath the existing burner pan to the area of the removed burner section. **(Figure 51)**
- 12) Mount the pilot assembly to the removed burner pan using the screws provided with the pilot assembly. Be careful not to kink the pilot assembly tube as it can severely damage the pilot tube. **(Figure 52)**
- 13) Place the removed burner top back on to the orifice block and secure tightly with the pan head screws.
- 14) With gas line installed, complete burner lighting instructions on page 66 and full system initialization on page 67.

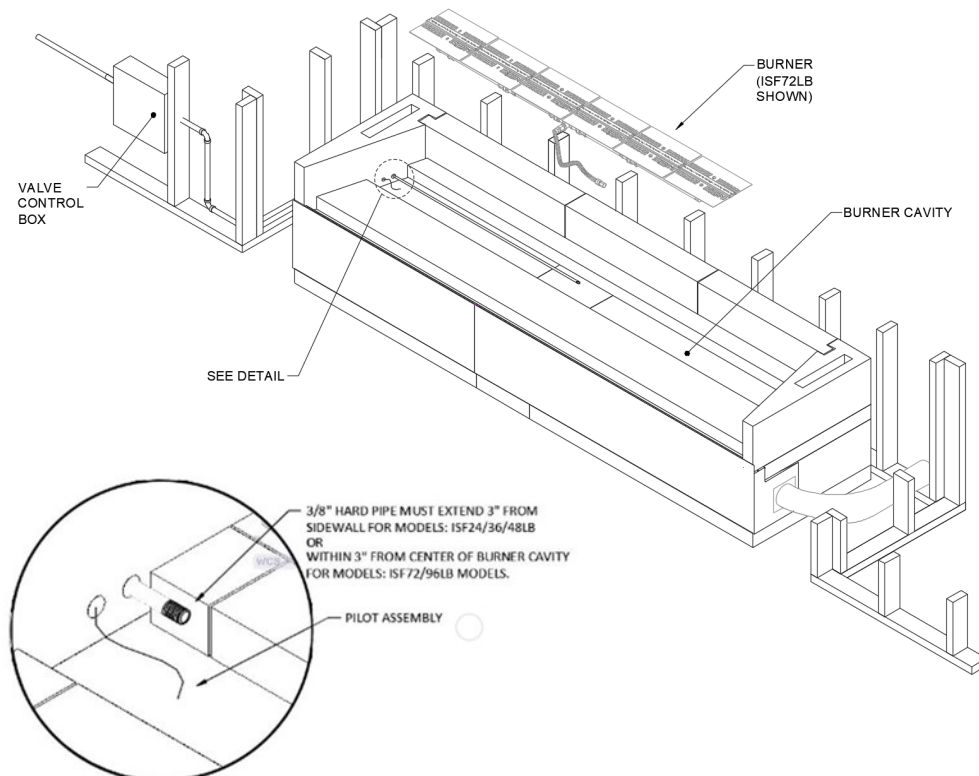

FIGURE 49

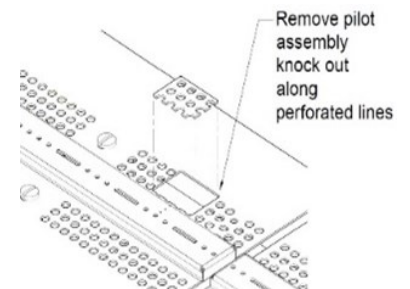

FIGURE 50

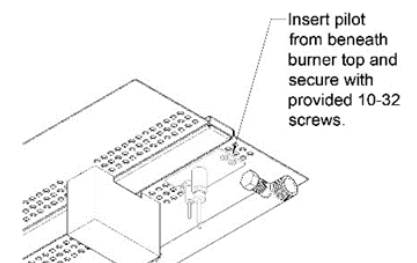

FIGURE 51

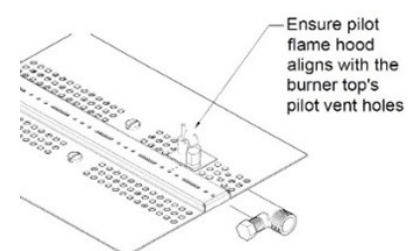
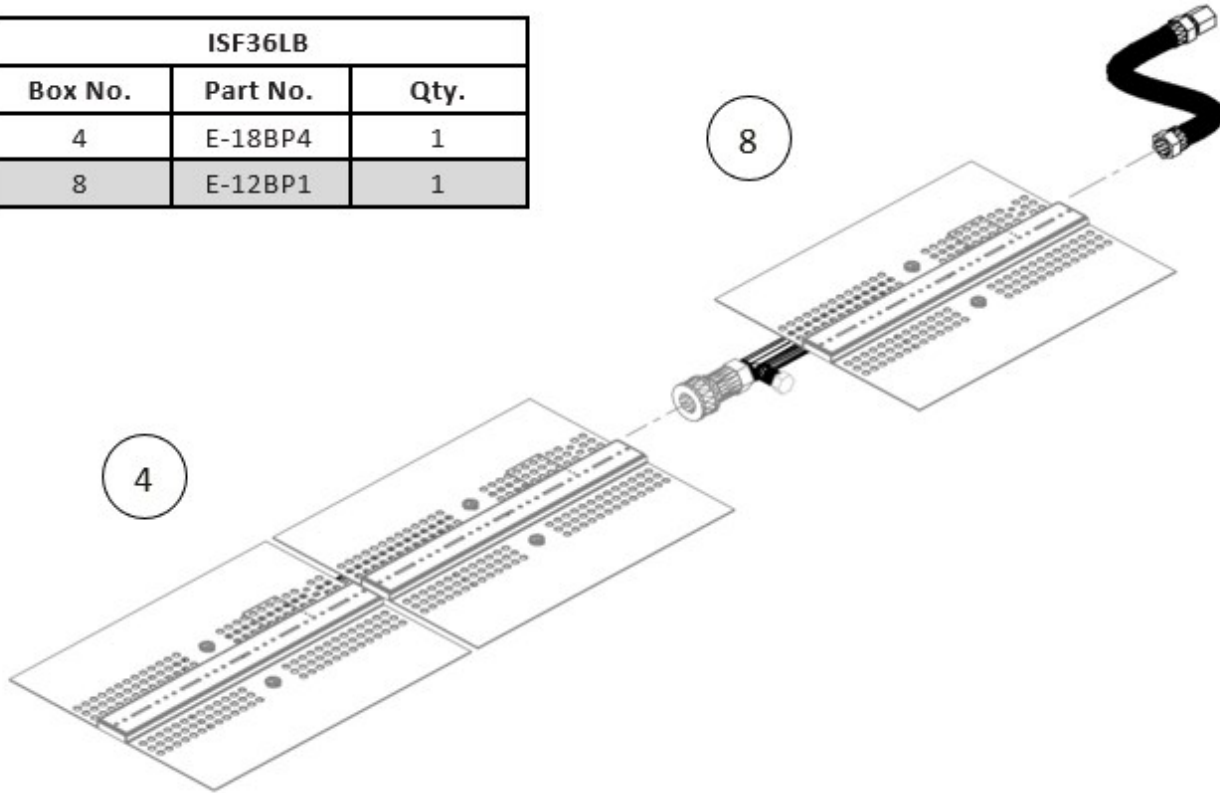

FIGURE 52

36” Burner Connection - ISF36LB (N/P)

For Isokern Maximus Linear 82L48

ISF36LB		
Box No.	Part No.	Qty.
4	E-18BP4	1
8	E-12BP1	1



60” Burner Connection – ISF60LB (N/P)

For Isokern Maximus Linear 82L72

ISF60LB		
Box No.	Part No.	Qty.
1	E-18BP1	1
4	E-18BP4	1
6	E-18BP6	1

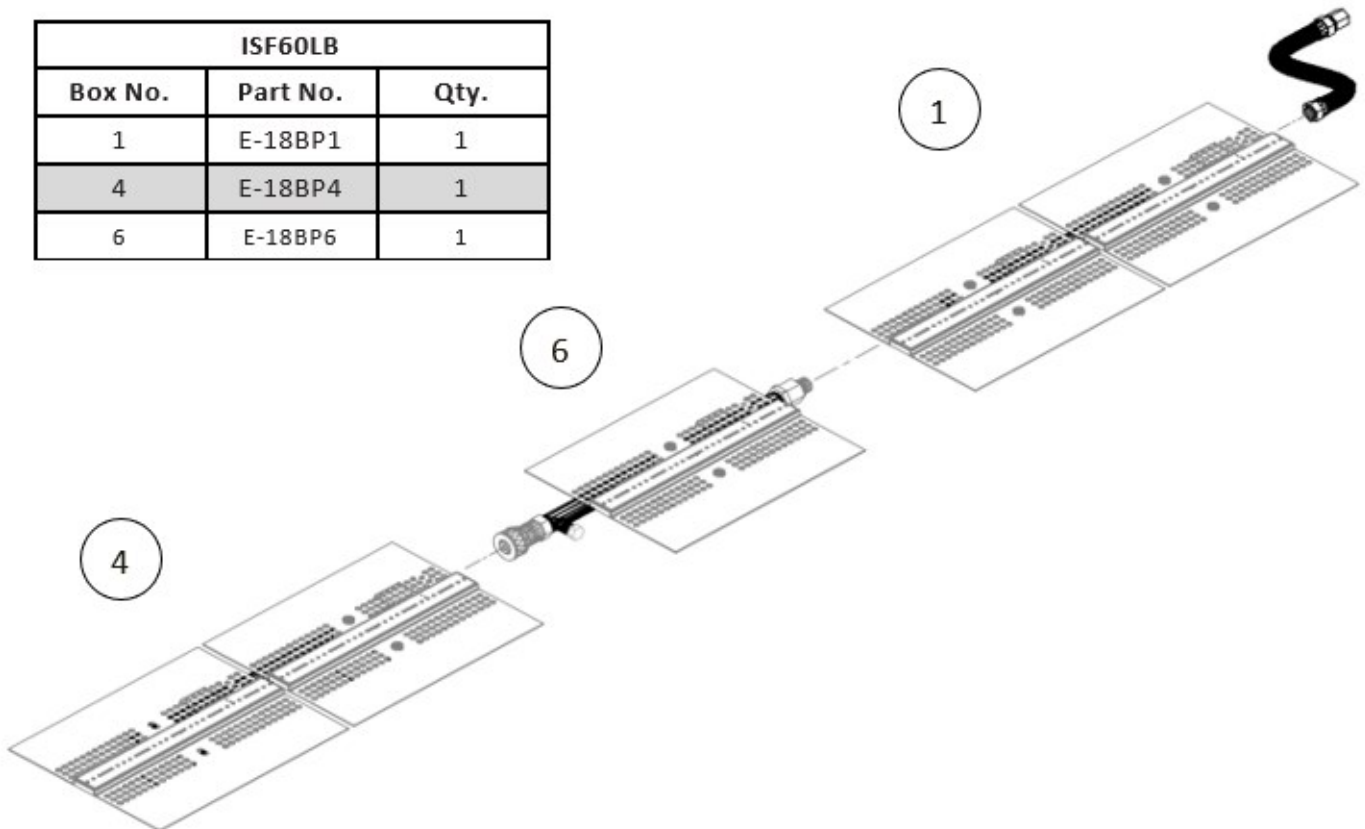

Remote Control System

The Remote allows you to power ON/OFF the fireplace appliance and adjust flame height from the comfort of your chair. It is configured to initialize the Meridian Control Panel powering on the fan and damper. Once draft is proved, the control will allow for burner to operate. The flame height can be adjusted by the remote through six (6) levels.

Important: the Battery Holder/ Switch that is included with the Isoflames Linear Burner is not used for remote operation of the Maximus Linear fireplace.



SYNCHRONIZE REMOTE TO CONTROL MODULE FOR THE FIRST TIME

- 1) Insert the three (3) provided AAA batteries into the battery bay in the remote. Correctly align polarity (+/-).
- 2) Press the red **"SW1"** button on the control module. The control module will beep 3 times and an amber LED is illuminated to indicate that the control module is ready to synchronize with a remote within 10 seconds.
- 3) Push the **"ON"** button on the remote. The control module will beep four (4) times to indicate acceptance of the remote's command. The system is now synchronized.

INITIALIZE WITH MERIDIAN CONTROL PANEL

Press the **"ON/OFF"** key on the remote (**Figure 53**). A single beep from module will confirm command. Press the **"MODE"** Key until **AUX** icon is visible (**Figure 54**). Press the **"Up Arrow Key"** to turn the **AUX** to **ON** and activate the Meridian Control Panel to power on the fan and damper. Press the **"MODE"** Key until **Flame Level** screen appears (**Figure 55**) then press the **"ON/OFF"** key to turn off system. The fireplace system will now initialize once the remote **"ON"** key is pressed.

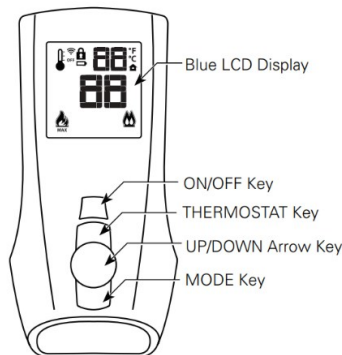

FIGURE 53

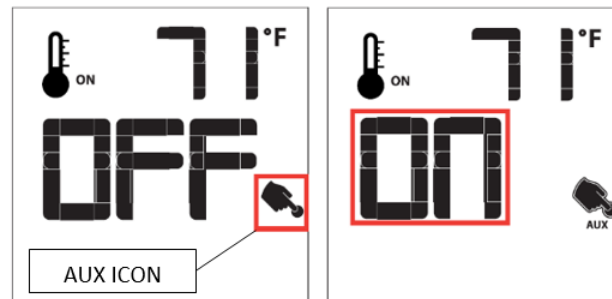

FIGURE 54

REMOTE FLAME CONTROL

The system has six (6) flame levels. See (**Figure 55**) for an example. With the system on, and the flame level at the maximum in the appliance, pressing the **"Down Arrow Key"** once will reduce the flame height by one step until the flame is turned off. The **"Up-Arrow Key"** will increase the flame height each time it is pressed. If the **"Up Arrow Key"** is pressed while the system is on, but the flame is off, the flame will come on in the high position (**Figure 55**). A single "beep" will confirm reception of the command.

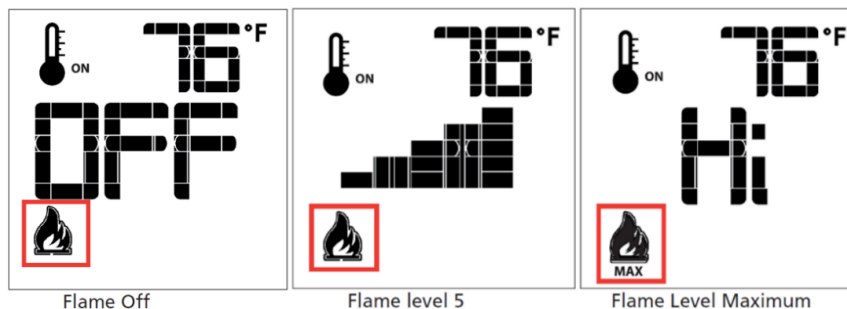

FIGURE 55

Remote Control System

TEMPERATURE INDICATOR DISPLAY

With the system in the “OFF” position, press the “**Thermostat**” Key and the “**Mode**” Key at the same time (Figure 53). Look at the LCD screen on the Remote to verify that a °C or °F is visible to the right of the Room Temperature display (Figure 56).

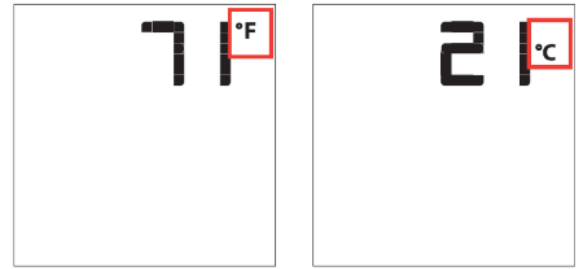

FIGURE 56

TURN OFF THE APPLIANCE

Press the “**ON/OFF**” Key on the Remote. The Remote LCD display will only show the room temperature and Icon and the appliance will turn off. A single “beep” from the Receiver confirms reception of the command.

FLAME COLOR AND BEHAVIOR

This appliance is designed for maximum heating efficiency. Therefore, upon lighting of the main burner, the flames will be semi-transparent or “bluish.” After 10- 20 minutes of operation the logs will heat up and the flames will become a yellow/orange color.

Adjusting the appliance to cause the flames to turn orange sooner may result in poor combustion, sooting, and a hazardous situation. See (Figure 57) showing proper flame appearance.

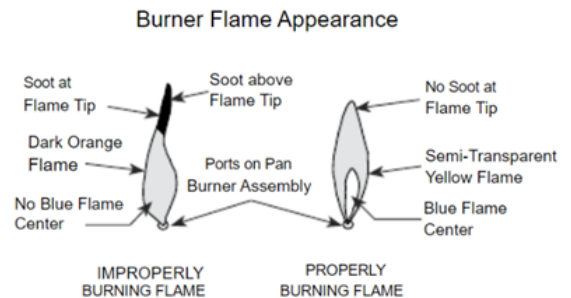

FIGURE 57

LOW BATTERY POWER DETECTION

The life span of the Receiver batteries depends on various factors: quality of the batteries used, the number of ignitions of the appliance, the number of changes to the room thermostat set point, etc.

When the Receiver batteries are low, two “beeps” will be emitted from the Receiver when it receives an “**ON/OFF**” command from the Remote.

This is an alert for a low battery condition for the Receiver. When the batteries are replaced the “beep” will be emitted from the Receiver when the “**ON/OFF**” key is pressed (See “Initializing the System”).

CONTINUOUS PILOT (CPI) & INTERMITTENT PILOT (IPI) SELECTION

With the system in “OFF” position press the “**Mode**” Key (Figure 53) to index to the **CPI** mode icon. Pressing the “**UP Arrow Key**” will return to **IPI**. A single “beep” will confirm the reception of the command (Figure 58). Remote default setting is set to **IPI**.

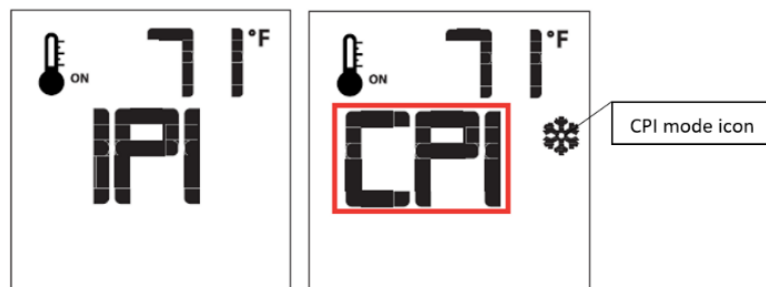

FIGURE 58

WARNING!!!: Fire hazard. Can cause severe injury or death. The receiver causes ignition of the appliance. The appliance can turn on suddenly. Keep away from the appliance burner when operating the remote system or activating manual bypass of the remote system.

WARNING!!!: Property damage hazard. Excessive heat can cause property damage. The appliance can stay lit for many hours. Turn off the appliance if it is not going to be attended for any length of time. Always place the Transmitter where children cannot reach it.

Burner Lighting Instructions

INSTALLER INSTRUCTIONS

It is required that the set of safety instruction labels that have been supplied with the appliance be affixed to the operation and control points of the appliance. It is the installers responsibility to ensure these warnings are properly affixed during installation. These warning labels are a critical step in informing consumers of safe operation of this appliance.

PRE-LIGHTING CHECKLIST

Be sure to check these items before the initial lighting of the appliance:

- Gas pressure has been checked carefully
- All gas fittings have been checked for leaks.
- All clearances to combustibles have been met
- All combustibles materials have been removed from the area in front of the appliance.
- All vented areas of the appliance face are unobstructed.
- House is ventilated to clear initial paint curing odors
- All packaging materials have been removed from the appliance.
- While appliance is cool, fingerprints or other marks have been cleaned from any plated surfaces with denatured alcohol and a soft cloth. Marks left on these surfaces may become permanent into the finish if not removed prior burning the unit.

WARNING!!!: IF YOU DO NOT FOLLOW THESE INSTRUCTIONS EXACTLY, A FIRE OR EXPLOSION MAY RESULT CAUSING PROPERTY DAMAGE, PERSONAL INJURY OR LOSS OF LIFE.

SAFETY INSTRUCTIONS

- A. This appliance is equipped with an ignition device which automatically lights the pilot. Do NOT try to light the pilot by hand.
- B. BEFORE OPERATING smell all around the appliance area for gas. Be sure to smell next to the floor because some gas is heavier than air and will settle on the floor.

WHAT TO DO IF YOU SMELL GAS:

- Do not try to light any appliance.
 - Do not touch any electric switch; do not use any phone in your building.
 - Immediately call your gas supplier from a neighbor's phone. Follow the gas supplier's instructions.
 - If you cannot reach your gas supplier, call the fire department.
- C. If any portion of this appliance does not operate as the instructions indicate, do not try to repair it, call a qualified service technician. Do not use tools. Force or attempted repair may result in a fire or explosion.
 - D. Do not use this appliance if any part has been under water. Immediately call a qualified service technician to inspect the appliance and to replace any part of the system and any gas control which has been under water.

MAIN POWER SWITCH, BATTERY HOLDER SWITCH PACK, AND REMOTE OVERVIEW

The Meridian Control Panel and the control module must have 120 VAC. The remote will not operate the appliance if power is not supplied to the Meridian Control Panel and control module. When wired correctly, the remote will initiate the fan and damper operation when the "ON/OFF" key is pressed. Once draft is proven, the Meridian Control Panel will allow the burner pilot to spark. Once pilot is ignited the main burner will turn on.

TO TURN OFF GAS TO APPLIANCE

- 1) Turn the main power switch in the "OFF" position
- 2) Turn off all electric power to the appliance if service is to be performed.
- 3) Close the main line gas shut-off valve.

WARNING!!!: OPERATION OF THIS APPLIANCE WHEN NOT CONNECTED TO A PROPERLY INSTALLED AND MAINTAINED VENTING SYSTEM CAN RESULT IN CARBON MONOXIDE (CO) POISONING AND POSSIBLE DEATH.

Full System Initialization

Once the burner system and the XVENTISO-Meridian Max Linear Fan System have been wired correctly, and the remote synchronized to the ignition module, a full system check is required.

- 1) Turn ON main gas supply to appliance.
- 2) Press the ON/OFF button on remote to turn ON appliance
- 3) Verify, if possible, that the fan and damper have been activated.
- 4) Once draft set point is reached, the Meridian Control Panel sends a signal to burner control module to allow for burner operation.
- 5) The burner pilot will begin sparking.
 - If pilot does not light after 30 seconds, turn off appliance for 30 seconds and retry step 2.
 - It may take several attempts to purge out all the air in pilot tube.
- 6) Once the pilot is ignited, the main burner valve will turn on within 7 seconds.
- 7) The burner should ignite, and the flames should travel along the length of the burner.
- 8) Initially, the flames will have a bluish appearance and will gradually become more yellow as appliance heats up.
- 9) After a few minutes, shut off burner by pressing OFF on the remote, allow the burner to cool to the touch.
- 10) Glass media can now be spread evenly across the entire the length burner. **DO NOT** leave excessive amounts of media directly on top of burner ports. **DO NOT** obstruct pilot assembly with glass media.
- 11) Restart sequence on step 2.
- 12) Observe flame pattern. Cycle through the variable flame levels of the burner with the remote until a satisfactory flame appearance has been achieved.
- 13) Once a satisfactory flame appearance has been achieved, system is complete.

Glass Panel Installation

- 1) Unpack the glass panels from the packaging. Inspect the glass for visible cracks or damage. If the glass panel(s) are compromised, do not install; the glass panels must be replaced.

NOTE: The glass panel package includes suction cups for lifting and handling the glass panel(s). Refer to the included instructions for suction cup use.

- 2) Lift the glass panel from the packaging with the suction cups. Orient the handles so that the shortest side of the glass will be in a vertical position when you lift the glass.
- 3) With the panel in an upright orientation, angle the top of the glass towards fireplace and insert the top edge of the glass panel into the channel of the Top Glass Bracket. In the same motion, raise the glass panel's top edge to fully seat in the Top Glass Bracket while swinging the bottom edge of the glass panel in towards the fireplace. The bottom edge of the glass should align to the rear ledge of the Air Collector Box's glass bracket, and the glass should be in a vertical orientation. Gently allow the glass panel to seat into the bottom Air Collector Box glass bracket (**Figure 59**).

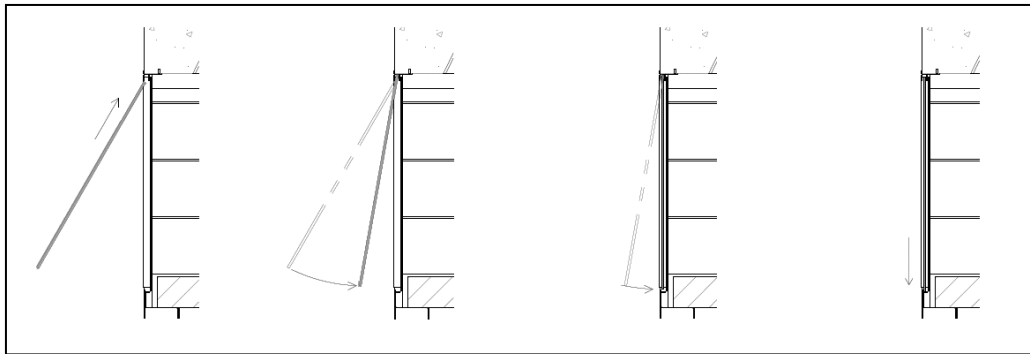

FIGURE 59

NOTE: If this is a multi-panel installation - models: 82L72-GFK, 82L96-GFK, 82L120-GFK, insert the glass in the center of the fireplace and gently slide the glass panel to the fireplace's left sidewall. Install the remaining glass panels in the same manner piecewise from left to right. (**Figure 60**).

NOTE: For glass panel installation on the 82L120-GFK, the larger glass panel must be installed in the center of the fireplace with the smaller glass panels to the outside of the fireplace's opening (**Figure 60**).

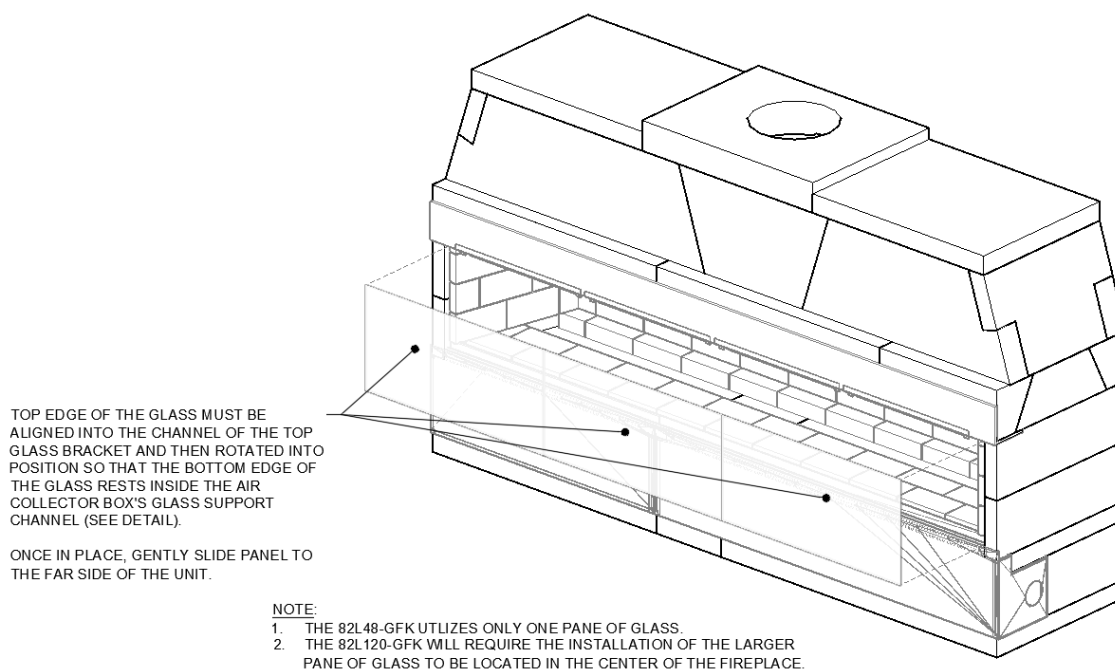

FIGURE 60

Troubleshooting

If an alarm event occurs during operation of the fireplace and exceeds the fault time, the X-VENTISO Meridian Control Panel will secure operations and must be manually reset.

To reset system after a fault lockout, cycle the run command to off.

After resetting a fault lockout perform a system test and troubleshoot cause of alarm.

IMPORTANT: The X-VENTISO Meridian controller is sealed from the factory and should require no adjustment of any user parameters. In the event that an alarm occurs and fails to clear, or the fireplace is not operating properly, contact KW at (817)-393-4029.

DO NOT ATTEMPT TO OPEN THE UNIT AND ALTER ANY SETTINGS. THIS WILL VOID THE WARRANTY.

The Meridian Control Panel has 4 main types of alarms. Their name, description, and possible causes can be found in the table below.





Alarm	Description	Possible Causes
DAMPER	<ul style="list-style-type: none"> • Flue damper end switch circuit is open • Flue damper failed to prove open for longer than the alarm delay timer setting 	<ul style="list-style-type: none"> • Damper actuator wiring • Mechanical blockage of damper • Actuator end switch settings • Actuator and damper timing • Actuator failure
AIR SWITCH	<ul style="list-style-type: none"> • Supply air switch circuit is open • The supply air switch did not prove supply air flow during operation for longer than the alarm delay timer setting 	<ul style="list-style-type: none"> • Dirty air filter • Duct blockage • Air switch wiring • Pressure tubing issue or connection • Air switch trip point adjustment • Supply fan disconnect or supply power • Supply fan wiring issue
LOW PRESSURE	<ul style="list-style-type: none"> • Low pressure limit exceeded • The system pressure measured by the pressure transducer is lower than the low limit setting for longer than the alarm delay timer setting 	<ul style="list-style-type: none"> • Flue fan speed too aggressive • Pressure tubing on wrong pressure transducer port • Pressure transducer wiring • Low limit set too high • Pressure transducer failure
HIGH PRESSURE	<ul style="list-style-type: none"> • High pressure limit exceeded • The system pressure measured by the pressure transducer is higher than the high limit setting for longer than the alarm delay timer setting 	<ul style="list-style-type: none"> • Flue fan speed not aggressive enough • Flue blockage • Motor failure or disconnect open • Damper issue • Pressure tubing on wrong pressure transducer port • Blocked pressure tubing or probe • Pressure transducer failure • Induced voltage into signal wiring • Too large of load for flue system

Troubleshooting

Earthcore Industries Technical Support: 1-800-642-2920
 KW at (817)-393-4029

Issue	Probable Cause	Possible Solution
Mechanical draft system inoperable	No power	<ul style="list-style-type: none"> • Verify power at the outlets • Verify wiring connections • Refer to draft system components installation manuals for detailed troubleshooting
	Draft system component alarm / failure	<ul style="list-style-type: none"> • Refer to draft system components installation manuals for detailed troubleshooting
No spark on pilot	No power	<ul style="list-style-type: none"> • Verify power is ON • Check wiring on ignition module , Meridian Control Panel, and gas valve are correct
	Ignitor misalignment	<ul style="list-style-type: none"> • Verify ignitor not contacting pilot gas hood
	Loose pilot connections	<ul style="list-style-type: none"> • Check pilot wiring assembly is tightly secured to ignition module
	Mechanical draft system error	<ul style="list-style-type: none"> • Refer to draft system components installation manuals for detailed troubleshooting
Pilot won't ignite	No spark	<ul style="list-style-type: none"> • See "No spark on pilot"
	Air in pilot gas line	<ul style="list-style-type: none"> • It may take a few minutes to purge out all the air from the pilot gas tube to ignite
	No gas	<ul style="list-style-type: none"> • Verify pilot gas tube is threaded sufficiently to gas valve • Verify all gas connections going to and from gas valve are tight • Verify main gas-shutoff valve is in ON position
Pilot won't stay ignited	Flame sensor obstruction	<ul style="list-style-type: none"> • Remove any obstruction near pilot igniter and flame sensor
	Loose pilot connections	<ul style="list-style-type: none"> • Check pilot wiring assembly is tightly secured to ignition module
	Low gas pressure	<ul style="list-style-type: none"> • Verify adequate gas supply pressure
Remote won't work/ unresponsive	Range	<ul style="list-style-type: none"> • Remote is too far from receiver
	Batteries need replacement	<ul style="list-style-type: none"> • Replace batteries on remote transmitter
	Program remote to receiver	<ul style="list-style-type: none"> • Sync remote transmitter to ignition module; Page 64
Main burner won't ignite	Pilot won't ignite	<ul style="list-style-type: none"> • See "Pilot won't ignite"
	Pilot flame won't stay ignited	<ul style="list-style-type: none"> • See "Pilot won't stay ignited"
	Loose burner segments	<ul style="list-style-type: none"> • Verify burner segments are tight and secure
	Orifice blockage	<ul style="list-style-type: none"> • Remove burner top pan tray and visually inspect orifice gas block
	Defective valve/ignition module	<ul style="list-style-type: none"> • Replace gas valve or ignition module

Glass Media Options

Component	Part#	Description
	RFG-10-PB	1/2" REFLECTIVE POSEIDON BLUE FIRE GLASS (10 LB JAR)
	RFG-10-TC	1/2" REFLECTIVE TERRA COPPER FIRE GLASS (10 LB JAR)
	RFG-10-VB	1/2" REFLECTIVE VESPER BLACK FIRE GLASS (10 LB JAR)
	RFG-10-KD	1/2" REFLECTIVE KRYSTALLO DIAMOND FIRE GLASS (10 LB JAR)
	RFG-10-AD	1/2" REFLECTIVE AMBER DIAMOND FIRE GLASS (10 LB JAR)

Glass Media will be included with the Isoflames Linear Burner for each Maximus Linear Unit. A color selection will need to be chosen when ordering your fireplace unit. The following designated amount will be included for each size.

- 82L48: 3 (10lb) Jars
- 82L72: 5 (10lb) Jars
- 82L96: 7 (10lb) Jars
- 82L120: 9 (10lb) Jars

Appendix A

X-VENTISO Meridian Max Linear Fan System: Connection Diagram



Meridian Damper Assembly:

4-pin Molex to Damper Assembly



Meridian 350 Fan and Adapter:

3-pin Molex to Fan



Stack Pressure Probe and Tubing:

Upper (+) Port at side of



Room Pressure Sensor and Tubing:

Lower (-) Port at side of Meridian

Stack Pressure (+)

Room Pressure (-)



Meridian Control Panel

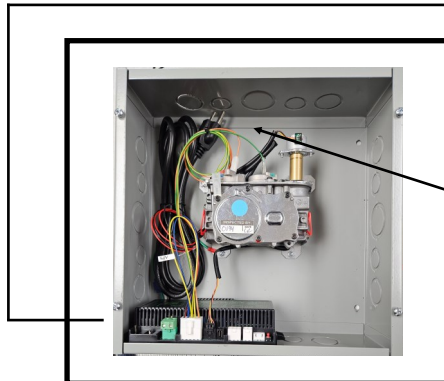

E-VKN/ E-VKP Gas Valve:

4-pin Molex to Gas Control Valve

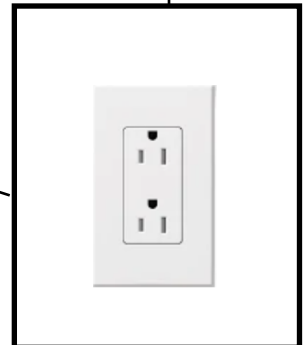

3-wire grounded power cord to 120 VAC / 15A outlet

THIS PAGE
INTENTIONALLY
LEFT BLANK

THIS PAGE
INTENTIONALLY
LEFT BLANK

Registration Card

Please tear along dash lines and send to:

Earthcore Industries

ATTN: Technical Department

6899 Philipps Industrial BLVD

Jacksonville, FL 32256

Dealer: _____ Date of Purchase _____

Date of Installation: _____

Address: _____

City, State, and Zip _____

Phone number: _____

Fireplace Model (circle one) 82L48 82L72 82L96 82L120

Gas Type(circle one): Natural Gas LP (Propane)

Glass Front (circle one) Yes No

Fireplace Serial Number: _____

Buyer: _____

Address: _____

City, State, and Zip _____

Phone number: _____

Installed By: _____

Address: _____

City, State, and Zip _____

Phone number: _____

Warranty & Disclaimer

Isokern Maximus Linear Series Gas Fireplace

ISOKERN offers a Lifetime Warranty for all Isokern components, to be free from defects in materials that negatively affect system performance from the date of purchase, subject to the terms and conditions of this limited warranty.

This warranty covers only the above stated components. THIS WARRANTY DOES NOT COVER DRAFTING, SMOKING OR PUFFING OF THE FIREPLACE SYSTEM. Factors beyond the manufacturer's control affect fireplace drafting, smoking, and puffing, and ISOKERN cannot guarantee these aspects of performance.

EXCLUSIONS AND LIMITATIONS

This Lifetime Warranty applies only if the Product is installed in the United States and Canada and only if operated and maintained in accordance with the printed instructions accompanying the Product and in compliance with all applicable installation and building codes and good trade practices. This warranty is non-transferable and extends to the original owner only. The following do not carry the Lifetime Warranty but are warranted as follows:

- Burner – Repair or replacement for five years from the date of installation
- Gas components & electrical components – Repair or replacement for one year from the date of installation
- Batteries – Replacement for 90 days from the date of installation
- Logs – Replacement for five years from the date of installation against thermal breakage only
- Remote controls – Repair or replacement for one year from the date of installation
- Parts not otherwise listed carry a 90 day warranty from the date of installation.

If a component is found to be defective under the terms of this warranty the party to whom this warranty is extended shall, notify ISOKERN, 6899 Phillips Industrial Blvd, Jacksonville, Florida 32256, in writing, by registered mail, within thirty (30) days following the discovery of the defect within the lifetime warranty period. The notice shall contain (1) the date of purchase; (2) place of purchase; (3) address of installation; (4) name, address and phone number of the owner; and (5) a brief description of the defect.

ISOKERN, or any division thereof, is not responsible for any labor costs or indirect costs incurred for the replacement of defective components.

ISOKERN is not responsible for misuse or mishandling of components. Nothing in this warranty makes ISOKERN, or any division thereof, liable in any respect for any injury or damage to the building or structure in which the fireplace or chimney system has been installed or to persons or property therein arising out of the use, misuse, or installation of properly manufactured ISOKERN product.

ISOKERN, OR ANY DIVISION THEREOF, SHALL NOT BE HELD LIABLE FOR ANY INCIDENTAL OR CONSEQUENTIAL DAMAGES OR EXPENSES ARISING OUT OF THE USE OF THE FIREPLACES OR CHIMNEY SYSTEMS. ALL SUCH DAMAGES AND EXPENSES ARE HEREBY EXCLUDED.

This warranty is null and void when the fireplace or chimney systems are not installed pursuant to the installation instructions provided by ISOKERN or local building codes have not been followed completely.

This warranty applies only to those fireplace and chimney systems installed in the continental United States and Canada. If any part of this warranty is found to be unenforceable, the remaining parts shall remain in force and effect.

ISOKERN HEREBY DISCLAIMS ALL GUARANTEES AND WARRANTIES, EXPRESS OR IMPLIED, BEYOND THE WARRANTIES SET FORTH HEREIN.

6899 Phillips Industrial Blvd. • Jacksonville, FL 32256 • 904.363.34

earthcore®