

Ø13 3/16" FLUE OUTLET. USE ONLY ECOSTEEL/ ECOSTEEL+ CLASS-A FLUE

TOP VIEW

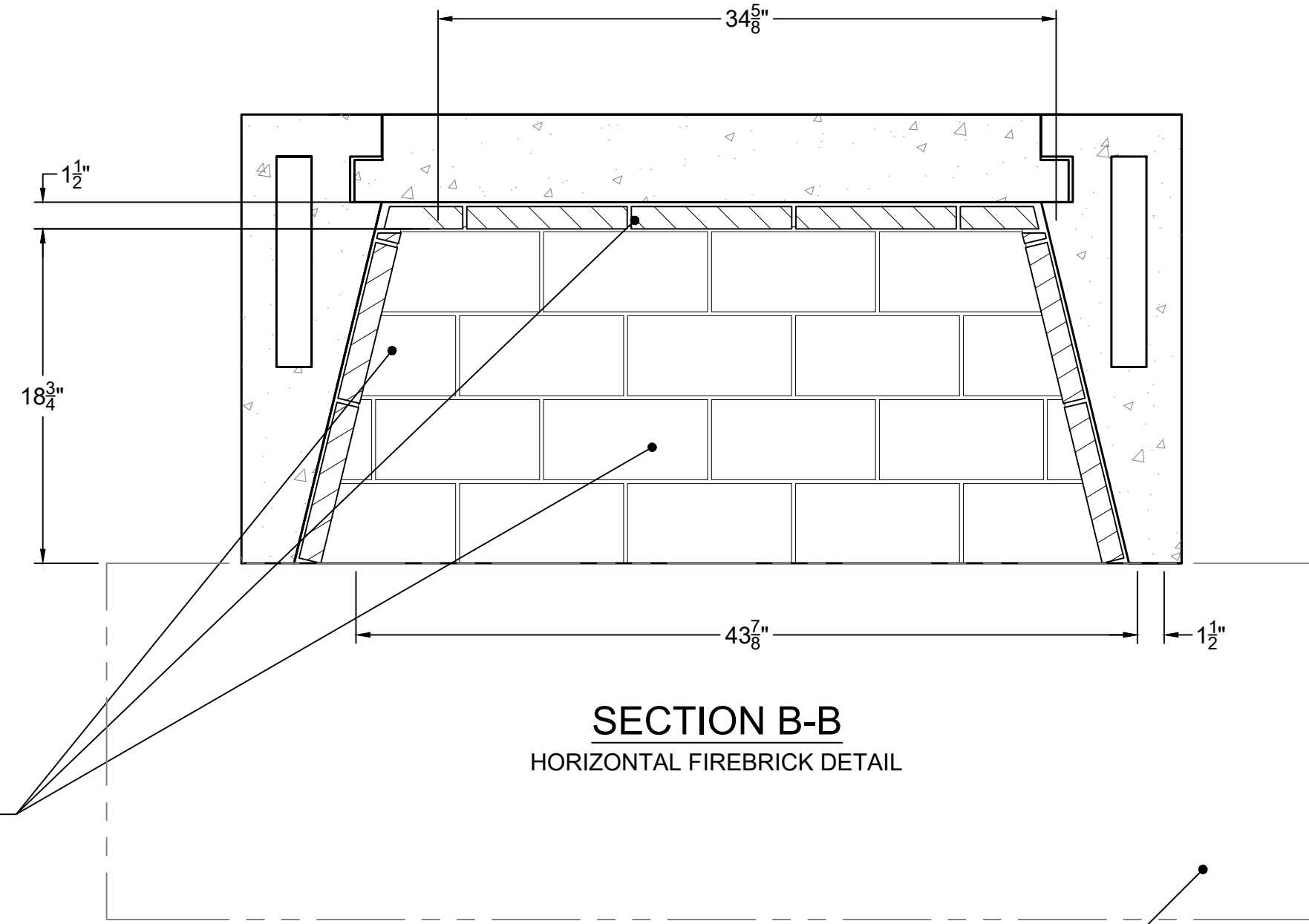

SECTION B-B  
HORIZONTAL FIREBRICK DETAIL

MINIMUM 1/4" THICK FIREBRICK W/ 1/4" MORTAR.

ISOKERN FIREBOX AND NONCOMBUSTIBLE HEARTH EXTENSION MAY BE INSTALLED ON COMBUSTIBLE FLOOR SYSTEM USING THE FIRELITE APPLICATION.

HEARTH EXTENSION SHALL EXTEND A MINIMUM OF 20" TO THE FRONT AND 12" TO THE SIDES OF FIREBOX'S FINISHED OPENING.

COMPONENT LIST		
PART #	DESCRIPTION	QTY.
13	SMOKE DOME (LARGE)	2
20	SIDEWALL	6
23	BASEPLATE-46" (STD)	1
31	BACKWALL-46" (STD)	3
34	TOP SLOPING	2
70	DAMPER BEAM-46"/48"	2
81A	TOP PLATE W/345mm HOLE (MAG)	1
95L	DAMPER END; LEFT	1
95R	DAMPER END; RIGHT	1
MS-S-46	46" STANDARD FIRELITE STAND	1
ISOWOOL	1/2" THICK ISOWOOL CERAMIC FIBER INSULATION BLANKET (INCLUDED W/ MS-S-46)	---

GENERAL NOTES

- DRAWINGS ARE FOR DESIGN PURPOSES ONLY AND ARE THE SOLE PROPERTY OF EARTHCORE INDUSTRIES. ANY REPRODUCTION OR UNAUTHORIZED USE IS STRICTLY PROHIBITED.
- EARTHCORE/ISOKERN OR ANY DIVISION THEREOF SHALL NOT BE HELD LIABLE FOR ANY INCIDENTAL OR CONSEQUENTIAL DAMAGES OR EXPENSES ARISING OUT OF THE USE OF THE FIREPLACES OR CHIMNEY SYSTEMS.
- ALWAYS CHECK LOCAL BUILDING CODES GOVERNING FIREPLACES AND FIREPLACE INSTALLATIONS.
- COMBUSTION AIR INLET KITS ARE RECOMMENDED BY EARTHCORE AND MAY HELP IMPROVE FIREPLACE OPERATION IN HOMES TIGHTLY SEALED AND WITH OTHER VENTILATING APPLIANCES INSTALLED. IF THE INSTALLATION IS TO BE LONGER THAN TEN FEET (10'), THEN THE SIX INCH (6") ADAPTER WILL BE NEEDED. THIS ADAPTER WILL ATTACH TO THE EXISTING FOUR INCH (4") SLEEVE OUTSIDE OF THE UNIT. THE SIX INCH ADAPTER INCLUDES AN ADDITIONAL TWENTY FEET OF 6" FLEX HOSE, FOR A MAXIMUM RUN OF THIRTY FEET (30').
- THE FIRE-LITE INSTALLATION REQUIRES USAGE OF ECOSTEEL/ECOSTEEL+ CLASS-A METAL FLUE SYSTEM.
- ALL PORTIONS OF THE COMBUSTIBLE FLOOR SYSTEM UNDER THE FIRE-LITE STAND ARE TO BE COVERED WITH MINIMUM 1/2" THICK CERAMIC FIBER ISOWOOL BLANKET; RATED TO 2100 DEGREES FAHRENHEIT.
- THE FIRELITE STAND'S NONCOMBUSTIBLE RAISED PLATFORM MUST BE SET WITH A MINIMUM ONE AND ONE HALF INCH (1-1/2") CLEARANCE TO THE WALLS TO THE SIDES AND DIRECTLY BEHIND THE FIRE-LITE ASSEMBLY. IF THESE WALLS CONTAIN UNSHIELDED INSULATION, IT MUST BE KEPT A MINIMUM OF THREE INCHES (3") AWAY FROM FIREBOX ASSEMBLY.
- ISOKERN IS NOT RESPONSIBLE FOR STRUCTURAL FLOOR SUPPORT DETAILS FOR THE FIRE-LITE FIREPLACE. FLOOR FRAMING WILL NEED TO BE DESIGNED AND BUILT TO ACCEPT SUBSTANTIAL DEAD LOADS SPREAD OVER A RELATIVELY SMALL FLOOR AREA. CONSULT YOUR LOCAL STRUCTURAL ENGINEER FOR PROPER FLOOR SYSTEM DESIGN, SIZING, AND SPECIFICATIONS. THE APPROXIMATE FOOT PRINT AREA AND DEAD LOAD AMOUNTS MAY BE FOUND IN YOUR FIREPLACE OWNER'S MANUAL.

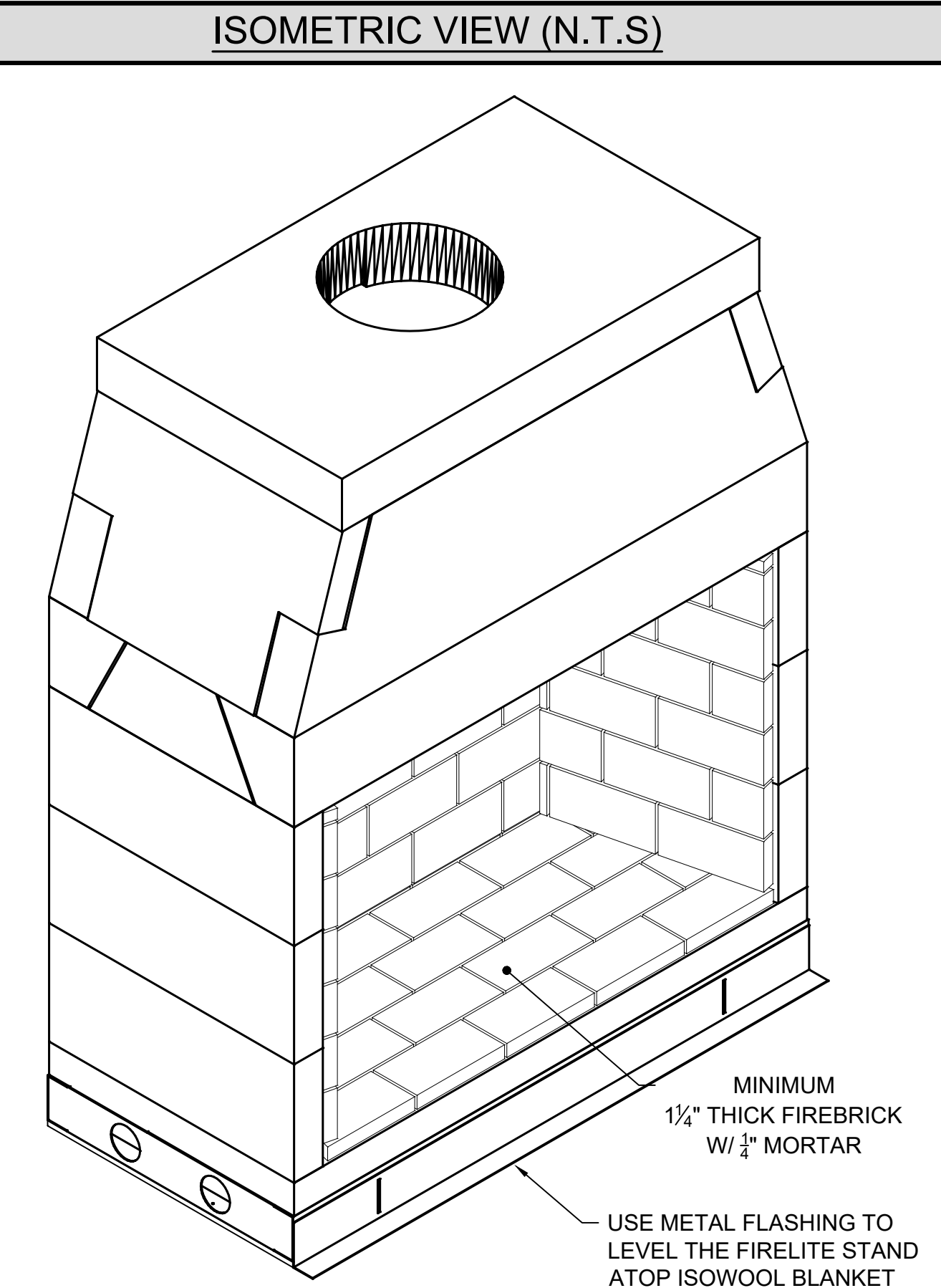

MINIMUM 1/4" THICK FIREBRICK W/ 1/4" MORTAR

USE METAL FLASHING TO LEVEL THE FIRELITE STAND ATOP ISOWOOL BLANKET

ISOMETRIC VIEW (N.T.S.)

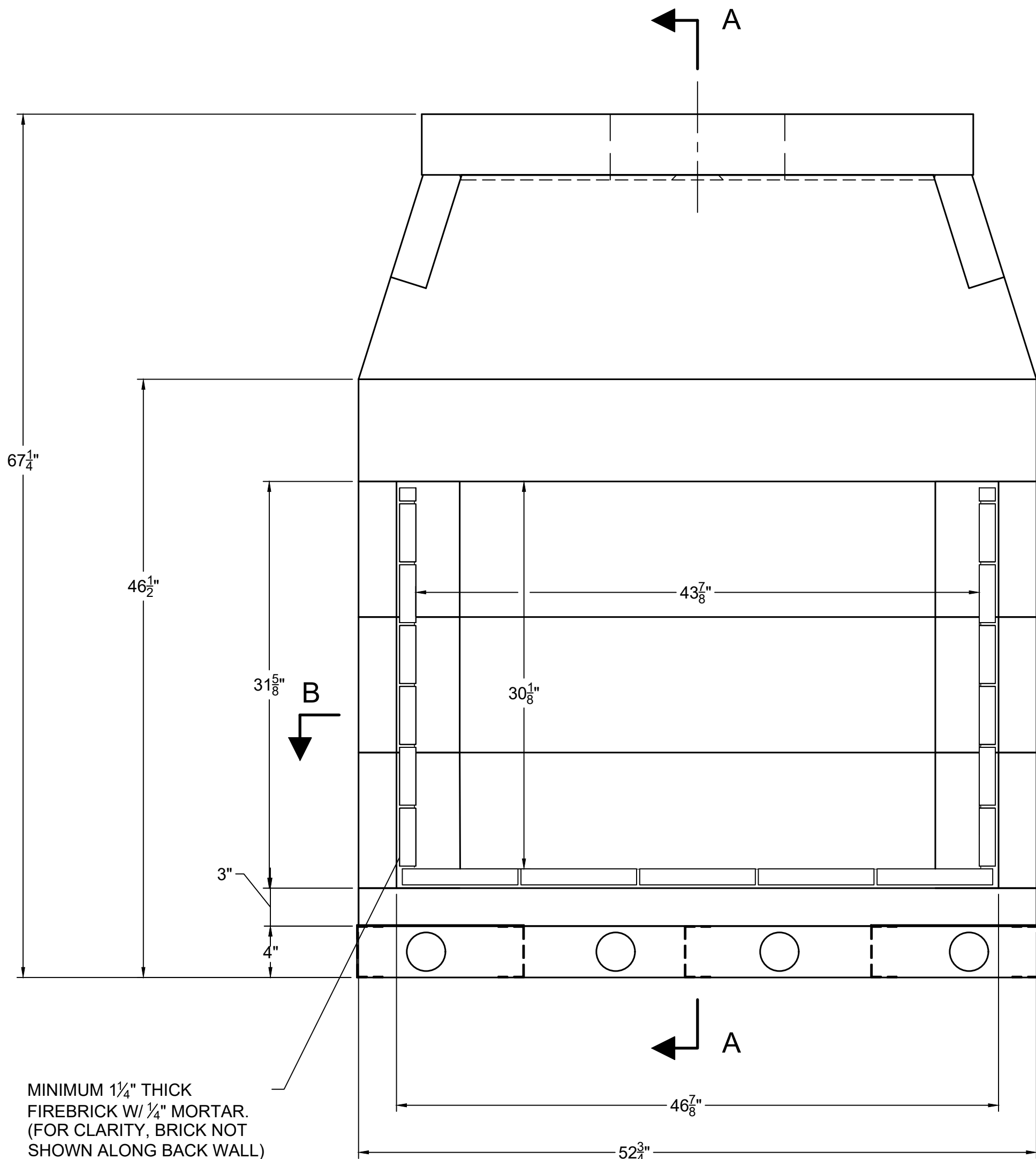

MINIMUM 1/4" THICK FIREBRICK W/ 1/4" MORTAR. (FOR CLARITY, BRICK NOT SHOWN ALONG BACK WALL)

FRONT VIEW  
\*MS-S-46 FLASHING NOT SHOWN IN VIEW\*

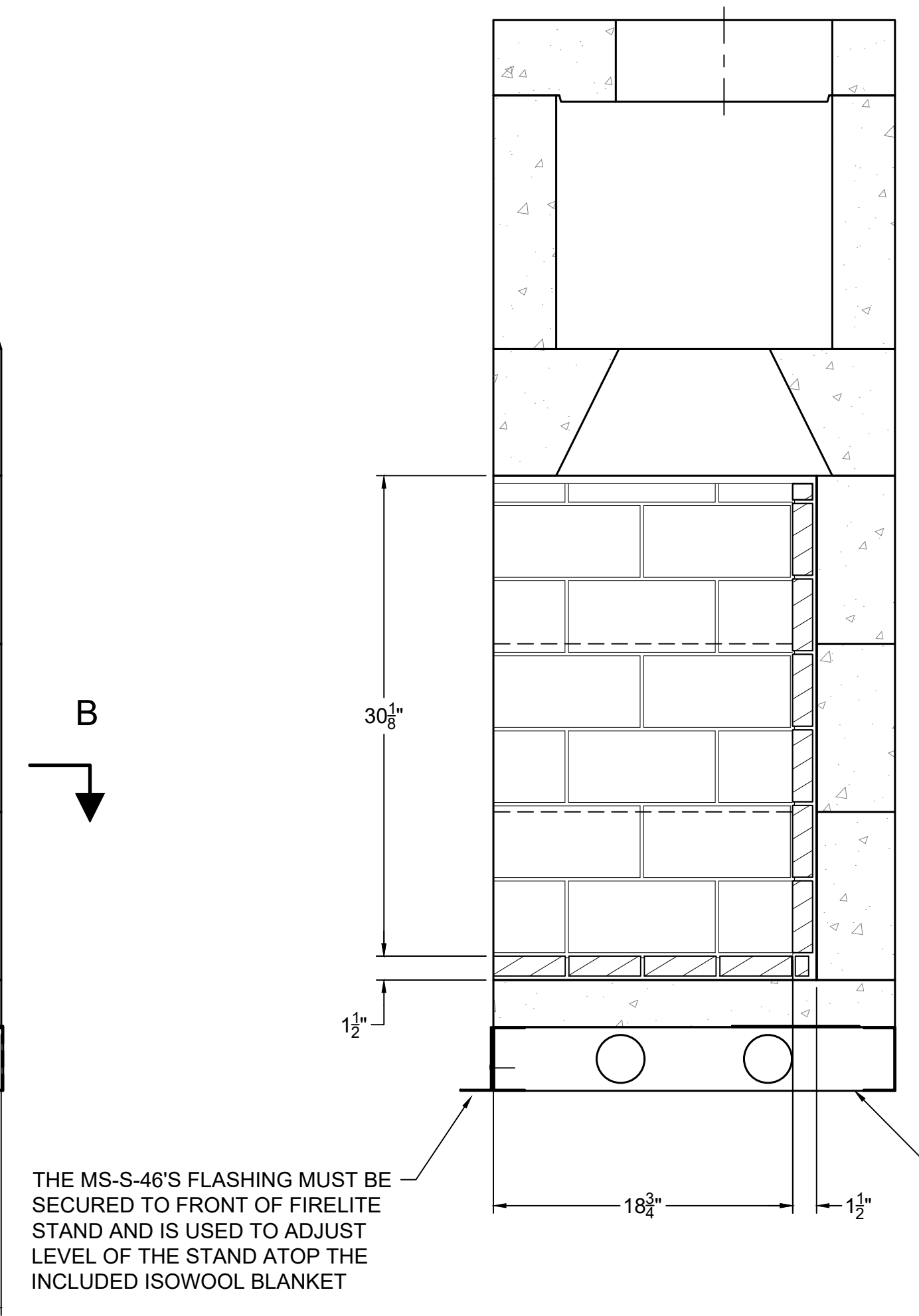

SECTION A-A  
VERTICAL FIREBRICK DETAIL

THE MS-S-46'S FLASHING MUST BE SECURED TO FRONT OF FIRELITE STAND AND IS USED TO ADJUST LEVEL OF THE STAND ATOP THE INCLUDED ISOWOOL BLANKET

ALL PORTIONS OF THE COMBUSTIBLE FLOOR SYSTEM UNDER THE FIRE-LITE STAND ARE TO BE COVERED WITH MINIMUM 1/2" THICK CERAMIC FIBER ISOWOOL BLANKET; RATED TO 2100 DEGREES FAHRENHEIT

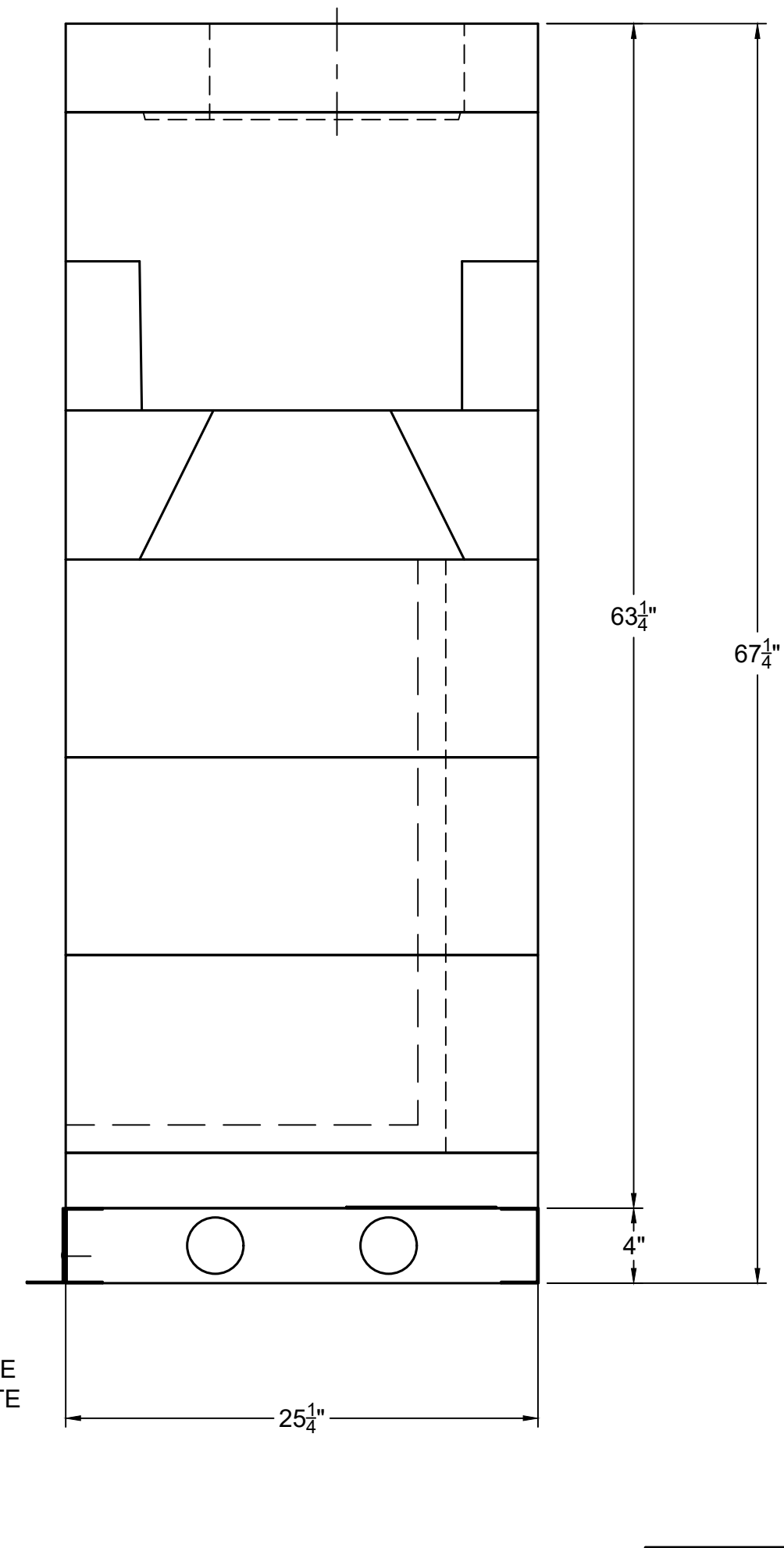

RIGHT-SIDE VIEW

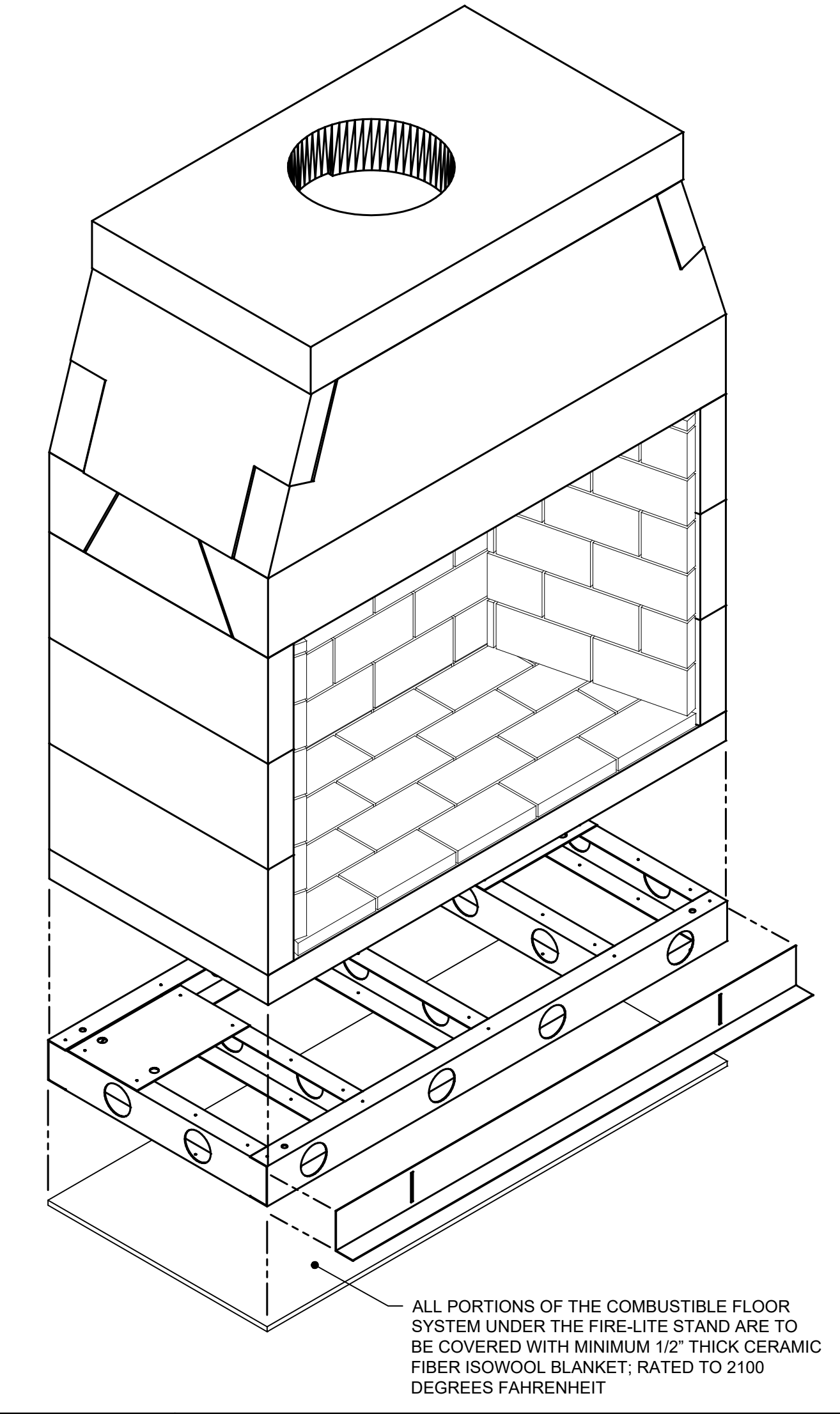

ALL PORTIONS OF THE COMBUSTIBLE FLOOR SYSTEM UNDER THE FIRE-LITE STAND ARE TO BE COVERED WITH MINIMUM 1/2" THICK CERAMIC FIBER ISOWOOL BLANKET; RATED TO 2100 DEGREES FAHRENHEIT

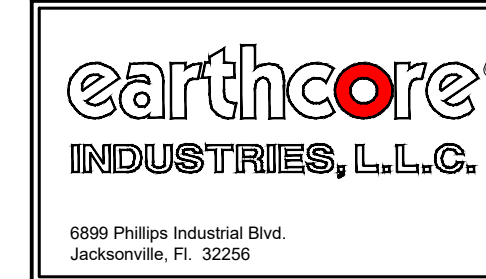

UNLESS OTHERWISE STATED, ALL DIMENSIONS ARE IN MILLIMETERS		PROJECT: 46" STANDARD WITH FIRELITE	
THIRD ANGLE PROJECTION		DESCRIPTION: FIREPLACE CONSTRUCTION DOCUMENT	
MATERIAL:	E.C. PUMICE MIXTURE	DATE:	9/9/2024
DRAWN:	K.B.H	SCALE:	1-1/2"=1'-0"
APPROVED:		DRAWING #:	80s46-FLK
		SHEET #:	1 OF 2

### Typical Installation Framing Dimensions

STANDARD	Width - A	Height - B	Depth - C
Model 36	46"	65"	26 3/4"
Model 42	52"	65"	26 3/4"
Model 46	56"	65"	26 3/4"

#### Notes:

- "B" includes the 3" thick base plate.
- "Raised hearth" requires additional rough opening height at "B" equal to the height of the raised hearth detail.
- Rough framing dimension for width "A" allows for the required 1 1/2" clearance at the sides of the Fireplace.
- Rough framing dimension for Height "B" will need to be increased by 4" if the Firelite application is utilized.
- Rough framing dimension for depth "C" allows for the required 1 1/2" clearance at the back of the Fireplace. 26 3/4" is only for an interior wall as most exterior wall framing have insulation, even if the wall is 2x6, the foam they spray expands so typically 31" is allowed on an exterior wall

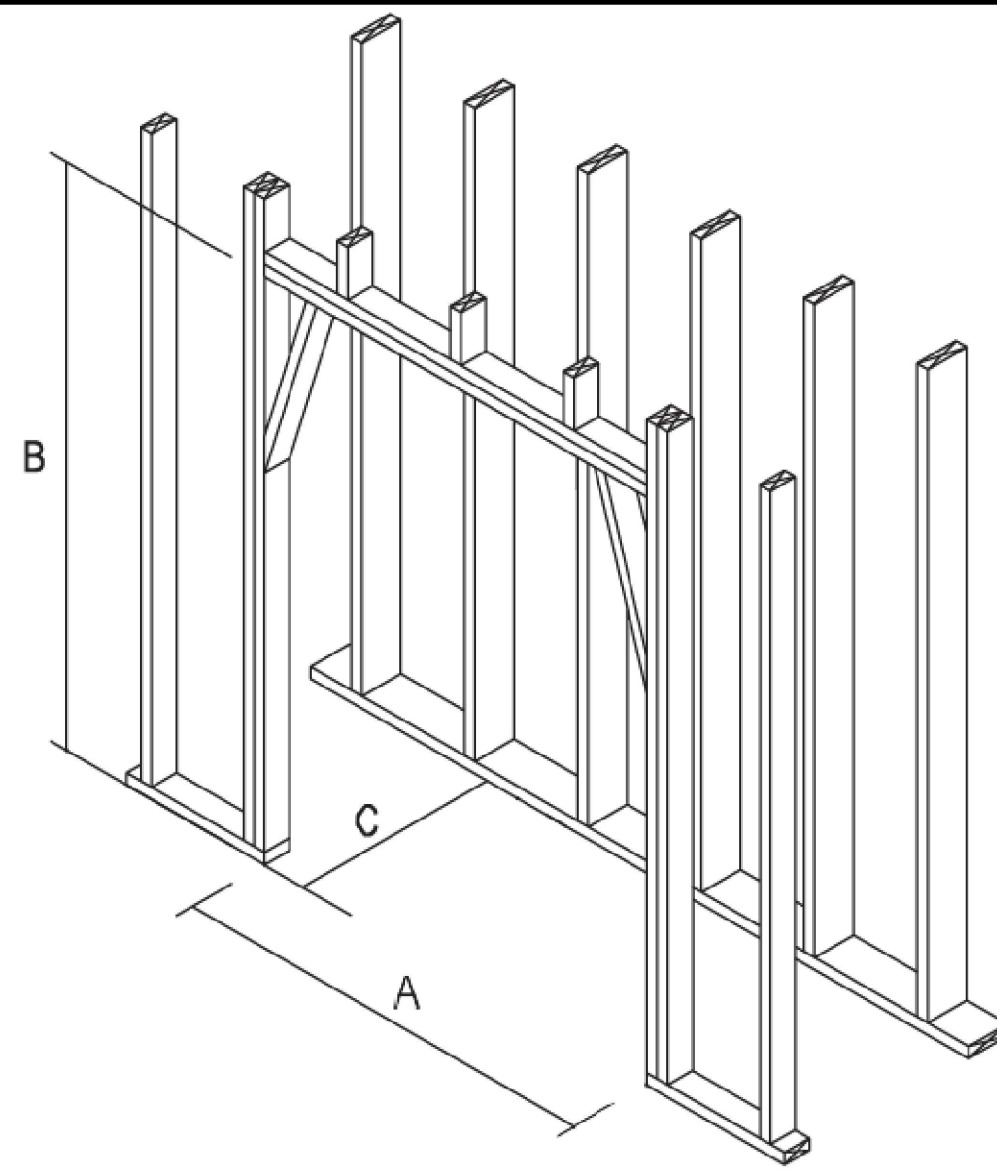

### Corner Installation Framing Dimensions

The following chart of dimensions detail the positioning of an STANDARD Series fireplace in a corner. It also details the positioning of DM chimney where it must turn 45° degrees, if alignment is needed to overhead framing.

STANDARD	A	B	C	D
Model 36	46"	23 1/2"	32"	69"
Model 42	52"	26 1/2"	36"	73"
Model 46	56"	28 1/2"	39"	76"

To turn flue 45°, first set starting inner liner onto the top plate of the fireplace.

Next, set a DM outer casing onto the inner liner so that the outer casing is at 45° to the firebox and square to the overhead framing system. Run the vertical DM chimney through the overhead framing.

Offset blocks can be used, if necessary, to align with overhead framing before running the vertical DM chimney outer casing and liner.

**NOTE:** Support the third offset down to footings and at each third offset block thereafter.

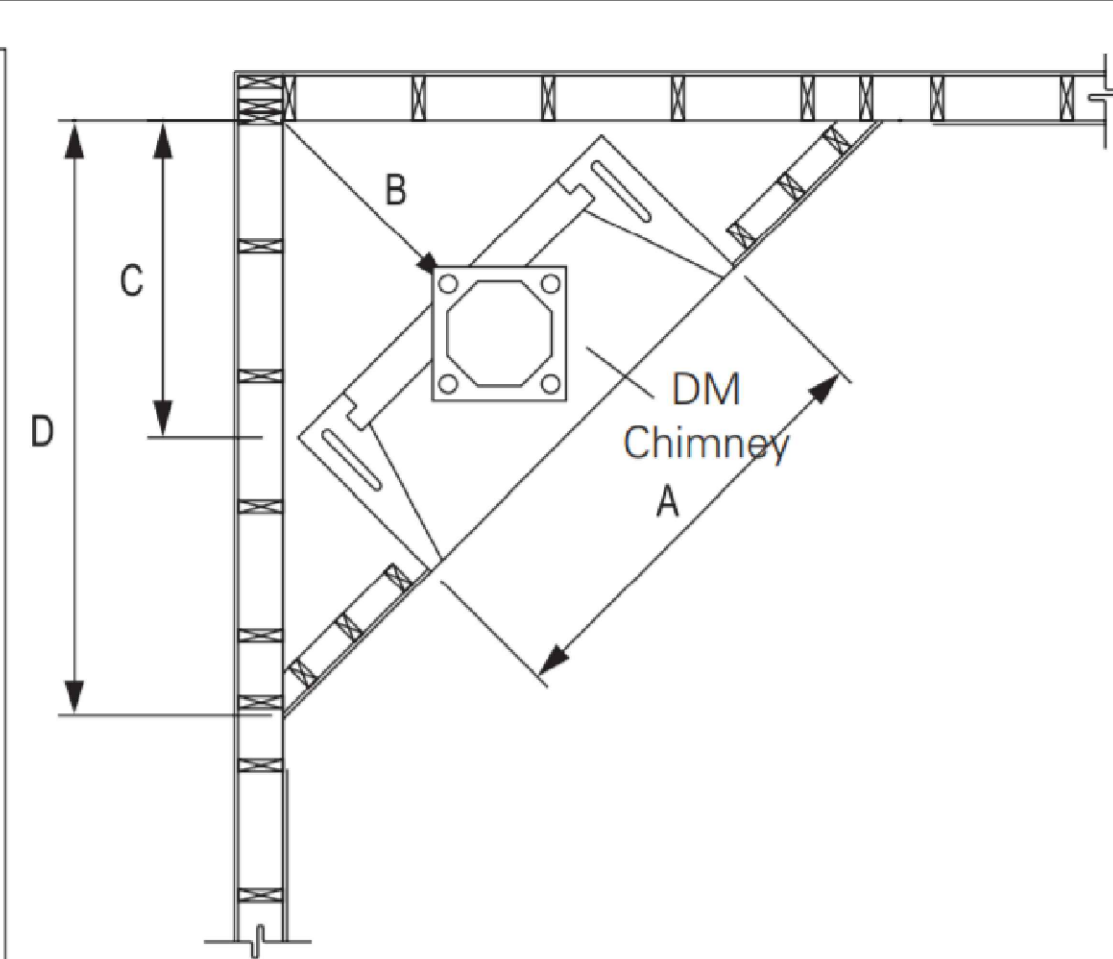

### Clearance to Combustible Trim - 36, 42 & 46 Models

#### Hearth Extensions

All STANDARD 36, 42 and 46 Fireplaces shall have hearth extensions of brick, concrete, stone, tile or other code approved noncombustible material. Suitable hearth extension material for the fireplaces shall be placed on the hearth extension's noncombustible substrate and must extend to at least twenty inches (20") in front of the fireplace's finished opening and must extend to at least twelve inches (12") beyond the sides of the finished fireplace opening. (Figure 68)

**WARNING:** The noncombustible hearth extension, by code, must sit on noncombustible substrate which shall have no wood underpinnings.

This means that off-grade wood floor systems shall be constructed in such a way that all wood floor joists and sub-flooring shall stop twenty inches (20") out from the front of the firebox. (Figure 69)

#### Mantle and Mantle Shelf Clearances

Fireplaces are subject to the same building code safety clearances to combustible trim as with any radiant heat fireplace.

All combustible trim shall be kept at least eight inches (8") from the finished fireplace opening.

Combustible trim located along the sides of the fireplace opening, which project more than one and one-half inches (1 1/2") from the face of the fireplace, shall have additional clearance from the eight inches (8") equal to the projection.

Combustible projecting mantles - up to twelve inches (12") of projection - shall not be placed less than fourteen inches (14") from the top of the fireplace opening. Combustible mantles which project more than twelve inches (12") from the face of the fireplace, shall have additional clearance from the fourteen inches (14") equal to the projection.

**Note:** The local authority having jurisdiction may require greater clearances for projecting combustible mantle shelves. Be sure to check local building codes regarding required clearances to projecting combustible mantles.

Adjoining Walls. Side walls and walls to rooms adjoining fireplace installations cannot be closer than twenty-six inches (26") to the finished fireplace opening.

**Note:** "Clearance to Combustible Trim" are those distances required to ensure that a fireplace mantle or facing will not catch fire. In most cases the distances should also be adequate to prevent any discoloration or warping due to heat. However each installation presents a unique and completely different set of circumstances involving many variables.

These include paint or finish composition, previous exposure to heat, methods and quality of construction, air flow patterns, etc. Because of these variables, the manufacturer does not guarantee that heat warping or discoloration will never occur.

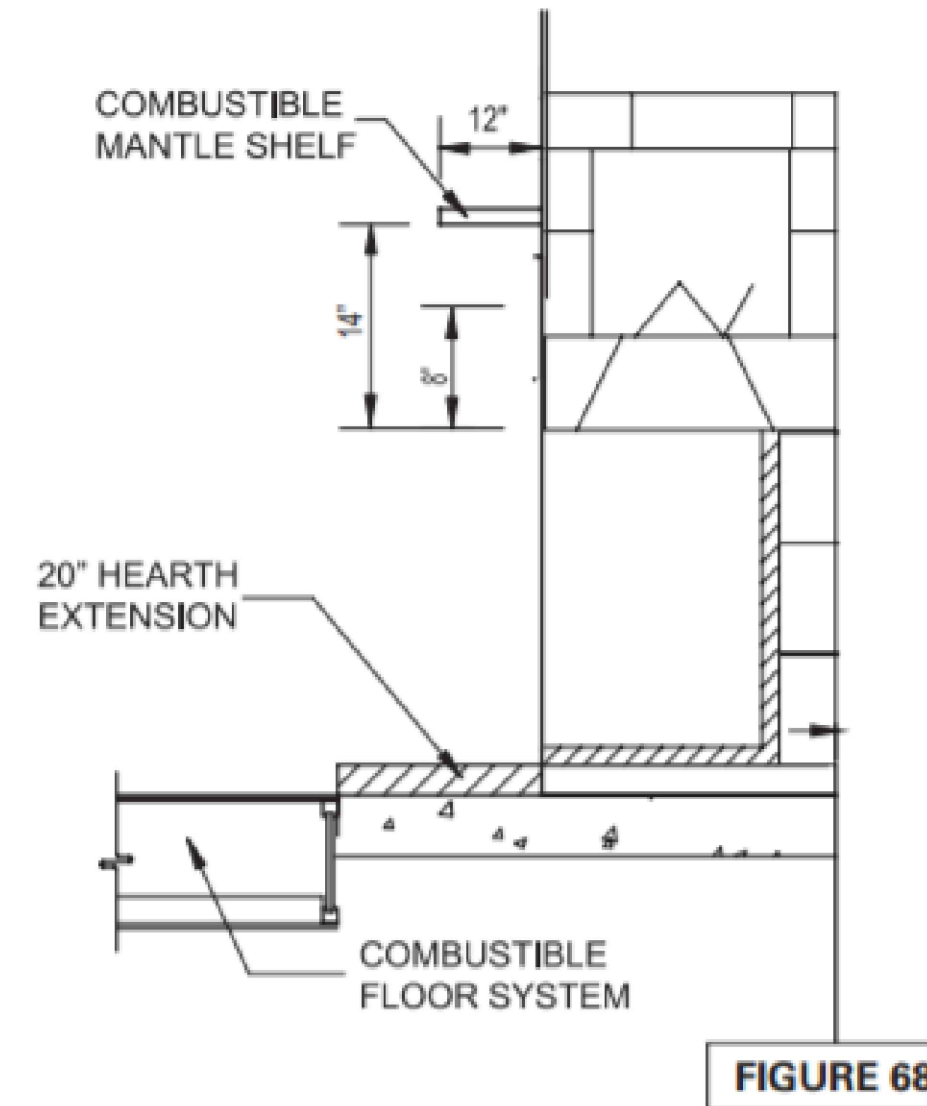

FIGURE 68

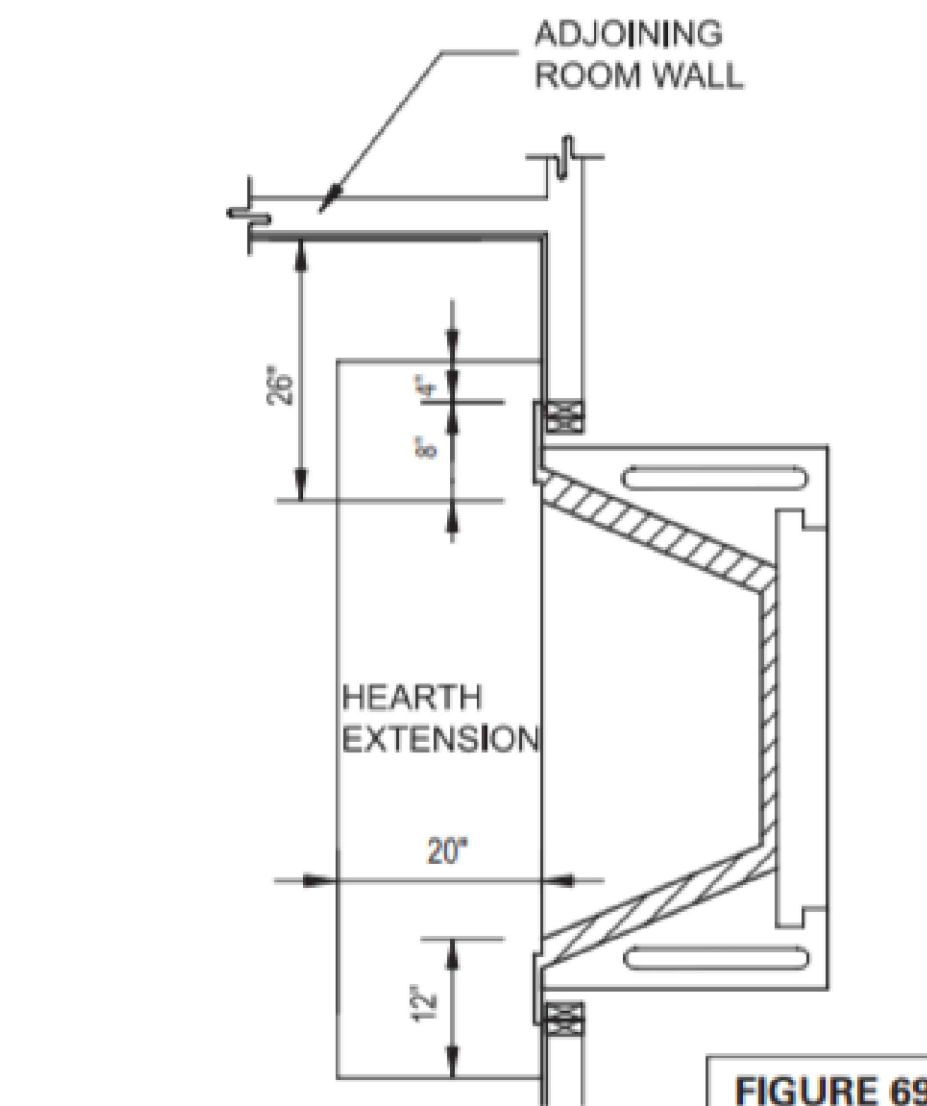

FIGURE 69

## Standard Series (All Fuel) Specifications

#### MANUFACTURER:

ISOKERN Fireplace and Chimney Systems, North America distribution by Earthcore Industries, LLC, Jacksonville, Florida (Telephone 800-642-2920)

#### PRODUCT DESCRIPTION:

Modular refractory masonry precast fireplace and chimney components.

- Designed for field assembly as a fireplace and chimney unit.
- All interlocking parts necessary for assembly of a complete firebox and smoke dome.
- Interlocking double module chimney components (DM).

#### MATERIALS:

- Light weight concrete of a proprietary mixture of Icelandic volcanic aggregate and cement for precast firebox, chimney block and flue liner components.
  - Compressive Strength: Firebox and Chimney Block: 972 psi.
  - Compressive Strength: Flue Liner: 1175 psi.
- Premixed (dry) EARTHCORE ADHESIVE.
  - Tensile strength: 807 psi; Compressive strength: 2460 psi.
  - Tested per ASTM C109, ASTM C307, and ANSI 118.4.
- Standard 1-1/8" thick high temperature refractory brick to line firebox interior
- Standard cast iron poker-style damper (optional top mount or in-line damper available).

#### INSTALLATION:

- Reference manufacturer's installation instructions for standard configurations, weights, sizes and installation details.
- Suitable masonry foundation and noncombustible hearth extensions must be provided.
- Unit to be assembled on site per manufacturer's illustrated instructions.
  - Premixed EARTHCORE ADHESIVE is used at all joints between components.
  - Firebox to be lined with a minimum 1-1/8" thick rated firebrick.
- A 1-1/2" minimum clearance to combustible materials is required.
- A 3" minimum clearance to insulation required.

#### CERTIFICATION:

- Warnock Hersey/Intertek Testing Services Report No. 632-912500; 3159656MID008; 3082504-T1
- Meets or exceeds UL 103HT; UL 103; UL 127; UL 1777; ULC 5610; ANSI 223.1.

#### CODE COMPLIANCE:

- SBCCI NO. 9626
- LARR NO. 25483
- NYC-MEA 241-90-E
- ICC REPORT NO. ESR 2316
- IBC 2006, IRC 2006, IMC 2006

**NOTE:** Isokern components are a natural material and slight variations in dimensions may occur. These should be no more than 1/8".

### SCAN QR CODE FOR LATEST INSTALLATION MANUALS





Intertek  
W/N 04895  
DO NOT REMOVE OR COVER THIS LABEL

**MODULAR REFRACTORY FIREPLACE**

STANDARD:  36"  42"  46"  
80S36 80S42 80S46

CERTIFIED TO: UL 127, ULC S610

**WHI-**

CLEARANCE TO COMBUSTIBLES:

SMOKE DOME FRONT AND ISOKERN CHIMNEY	= 0 in.
UNIT SIDES AND REAR	= 1.5 in. (38mm)
COMBUSTIBLE SHEATHING ABOVE OPENING	= 8 in. (203mm)
TOP SHEATHING OR TRIM TO OPENING SIDES	= 8 in. (203mm)
MANTEL ABOVE OPENING	= 14 in. (356mm)
OPENING TO SIDEWALL	= 26 in. (660mm)
HEARTH EXTENSION BEYOND FRONT	= 20 in. (508mm)
HEARTH EXTENSION BEYOND SIDES	= 12 in. (305mm)
COMBUSTIBLE FLOOR (MUST USE FIRE-LITE APPLICATION)	= 4 in. (102mm)
INSULATION FROM FIREBOX	= 3 in. (76mm)

USE SOLID WOOD FUEL OR LISTED DECORATIVE GAS VENTED OR UNVENTED APPLIANCE. ALSO FOR USE WITH LISTED METAL CHIMNEY. FIRE-LITE APPLICATION TO USE ECO-STEEL CHIMNEY ONLY.

DO NOT USE A FIREPLACE INSERT OR OTHER PRODUCTS NOT SPECIFIED FOR USE WITH THIS PRODUCT. "WARNING" THIS FIREPLACE HAS NOT BEEN TESTED FOR USE WITH GLASS DOORS. TO REDUCE THE RISK OF FIRE OR INJURY, DO NOT INSTALL GLASS DOORS. IF DOORS ARE USED, OPERATE FIREPLACE WITH DOORS FULLY OPEN, WHEN BURNING A DECORATIVE GAS APPLIANCE IN THE FIREPLACE, LOCK THE DAMPER TO THE FULLY OPEN POSITION. DO NOT OPERATE AN UNVENTED GAS LOG SET IN THIS FIREPLACE WITH THE CHIMNEY REMOVED.

SEE INSTALLATION AND OPERATING INSTRUCTIONS FOR THIS MODEL AND ICC # ESR-2316.

CONTACT BUILDING OFFICIAL PRIOR TO INSTALLATION  
REFER TO INTERTEK'S DIRECTORY OF BUILDING PRODUCTS FOR DETAILED INFORMATION.

**ISOKERN**

MADE IN USA  
Chesapeake, VA 23323

Headquarters  
Jacksonville, FL 32256

		UNLESS OTHERWISE STATED, ALL DIMENSIONS ARE IN MILLIMETERS		PROJECT: <b>46" STANDARD WITH FIRELITE</b>	
DESCRIPTION: <b>GENERAL INFORMATION AND SPECIFICATIONS</b>		THIRD ANGLE PROJECTION		MATERIAL:	
UNSPECIFIED TOLERANCES: ANG. X ± LIN. X ± XX ±	DATE: 9/9/2024	SCALE: N.T.S.	DRAWING #: 80s46-FLK	SHEET # 2	REV: E
APPROVED:		DATE:		DO NOT SCALE	
888 Phillips Industrial Blvd. Jacksonville, FL 32256					