

Rough Framing Dimensions

Typical Installation Framing Dimensions

MAGNUM	Width - A	Height - B	Depth - C
Model 28	38 1/2"	61 1/2"	29 1/2"
Model 36	46"	71"	29 1/2"
Model 42	52"	71"	29 1/2"
Model 48	56"	71"	29 1/2"

NOTES:

- "B" includes the 3"-thick base plate.
- "Raised hearth" requires additional rough opening height at "B" equal to the height of the raised hearth detail.
- Rough framing dimension for width "A" allows for the required 1 1/2" clearance at the sides of the Fireplace.
- Rough framing dimension for depth "C" allows for the required 1 1/2" clearance at the back of the Fireplace. 29 1/2" is only for an interior wall as most exterior wall framing have insulation, even if the wall is 2 x 6, the foam they spray expands, so typically 31" is allowed on an exterior wall
- Rough framing dimension for Height "B" will need to be increased by 4" if the Firelite application is utilized.

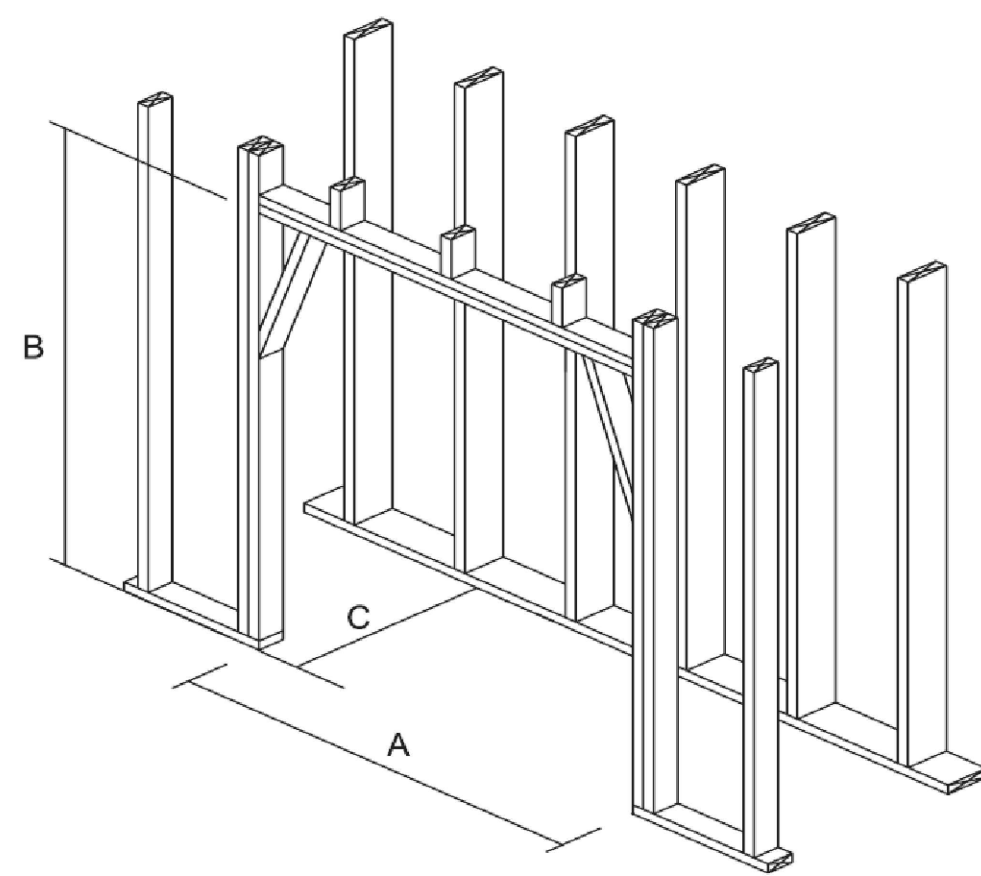

Corner Installation Framing Dimensions

The following chart of dimensions detail the positioning of an MAGNUM Series fireplace in a corner. It also details the positioning of DM chimney where it must turn 45° degrees, if alignment is needed to overhead framing

MAGNUM	A	B	C	D
Model 28	38 1/2"	20"	26 1/2"	68"
Model 36	46"	23 1/2"	32"	73"
Model 42	52"	26 1/2"	36"	77"
Model 48	56"	28 1/2"	39"	80"

To turn flue 45°, first set starting inner liner onto the top plate of the fireplace.

Next, set a DM outer casing onto the inner liner so that the outer casing is at 45° to the firebox and square to the overhead framing system. Run the vertical DM chimney through the overhead framing.

Offset blocks can be used, if necessary, to align with overhead framing before running the vertical DM chimney outer casing and liner.

NOTE: Support the third offset down to footings and at each third offset block thereafter.

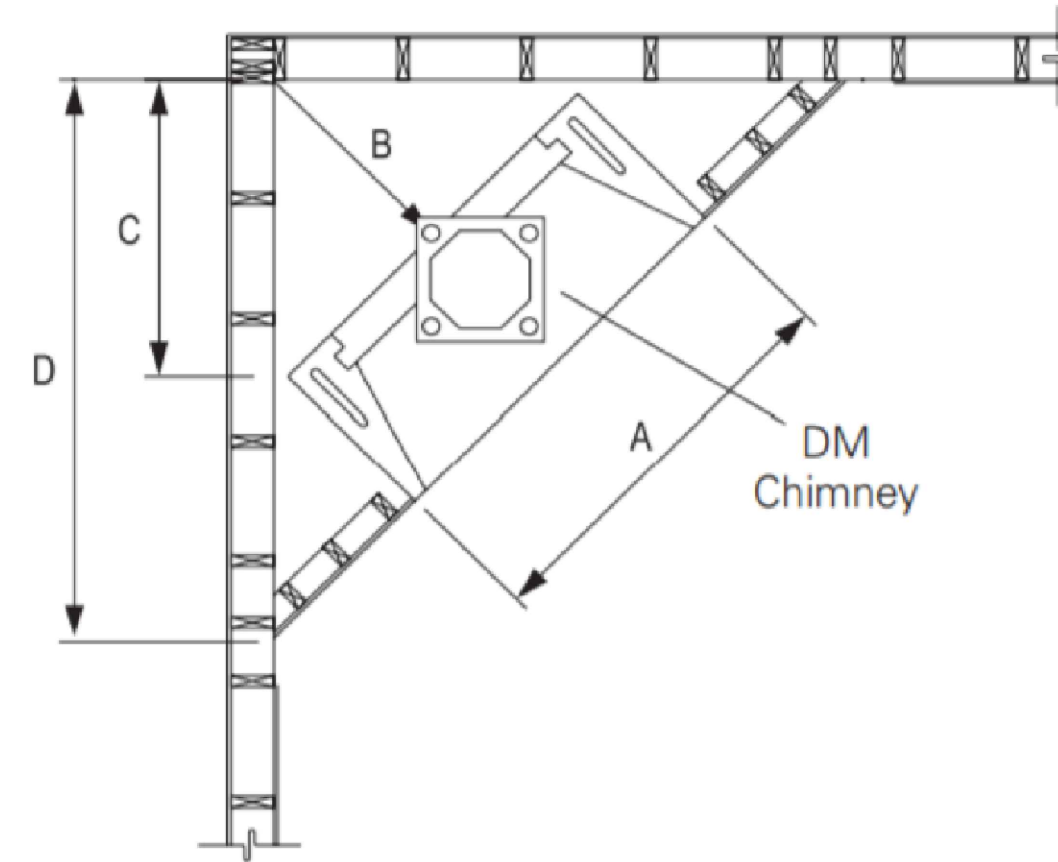

Clearance to Combustible Trim - 28, 36, 42 & 48 Models

Hearth Extensions

All MAGNUM 28, 36, 42, and 48 Fireplaces shall have hearth extensions of brick, concrete, stone, tile, or other code approved non-combustible material. Suitable hearth extension material for the fireplaces shall be placed on the hearth extension's non-combustible substrate and must extend to at least twenty inches (20") in front of the fireplace's finished opening and must extend to at least twelve inches (12") beyond the sides of the finished fireplace opening (Figure 68).

WARNING: The non-combustible hearth extension, by code, must sit on non-combustible substrate, which shall have no wood underpinnings. This means that off-grade wood floor systems shall be constructed in such a way that all wood floor joists and sub-flooring shall stop twenty inches (20") out from the front of the firebox (Figure 69).

Mantle and Mantle Shelf Clearances

Fireplaces are subject to the same building code safety clearances to combustible trim as with any radiant heat fireplace. All combustible trim shall be kept at least eight inches (8") from the finished fireplace opening. Combustible trim located along the sides of the fireplace opening, which project more than one and a half inches (1 1/2") from the face of the fireplace, shall have additional clearance from the eight inches (8") equal to the projection. Combustible projecting mantles – up to twelve inches (12") of projection – shall not be placed less than fourteen inches (14") from the top of the fireplace opening. Combustible mantles, which project more than twelve inches (12") from the face of the fireplace, shall have additional clearance from the fourteen inches (14") equal to the projection.

NOTE: The local authority having jurisdiction may require greater clearances for projecting combustible mantle shelves. Be sure to check local building codes regarding required clearances to projecting combustible mantles.

Adjoining Walls: Side walls and walls to rooms adjoining fireplace installations cannot be closer than twenty-six inches (26") to the finished fireplace opening.

NOTE: "Clearance to Combustible Trim" are those distances required to ensure that a fireplace mantle or facing will not catch fire. In most cases, the distances should also be adequate to prevent any discoloration or warping due to heat. However each installation presents a unique and completely different set of circumstances involving many variables. These include paint or finish composition, previous exposure to heat, methods and quality of construction, air flow patterns, etc. Because of these variables, the manufacturer does not guarantee that heat warping or discoloration will never occur.

FIGURE 68

FIGURE 69

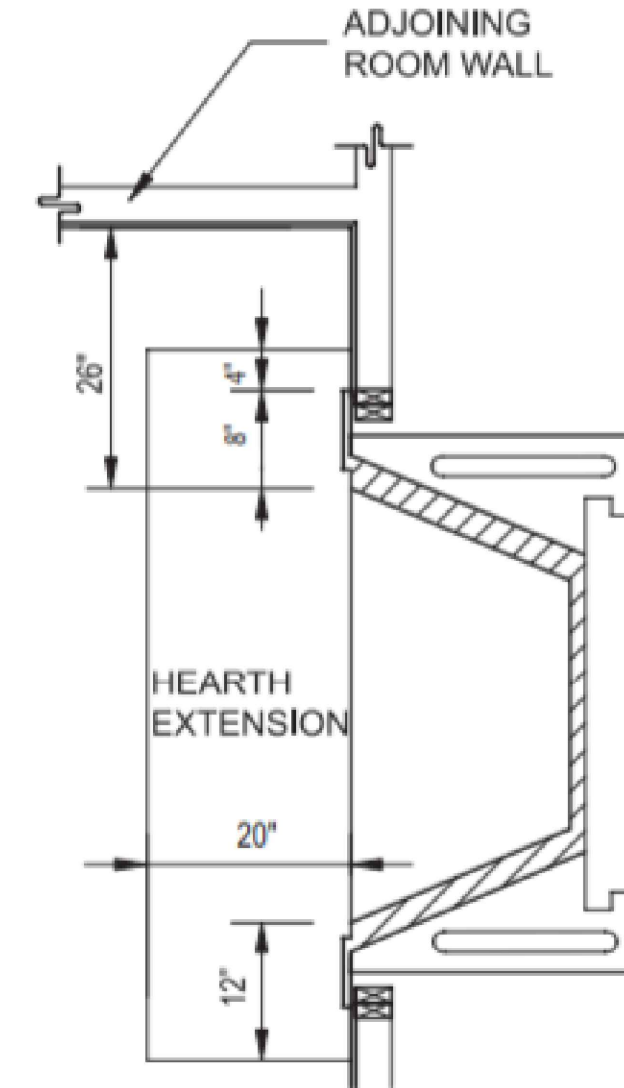
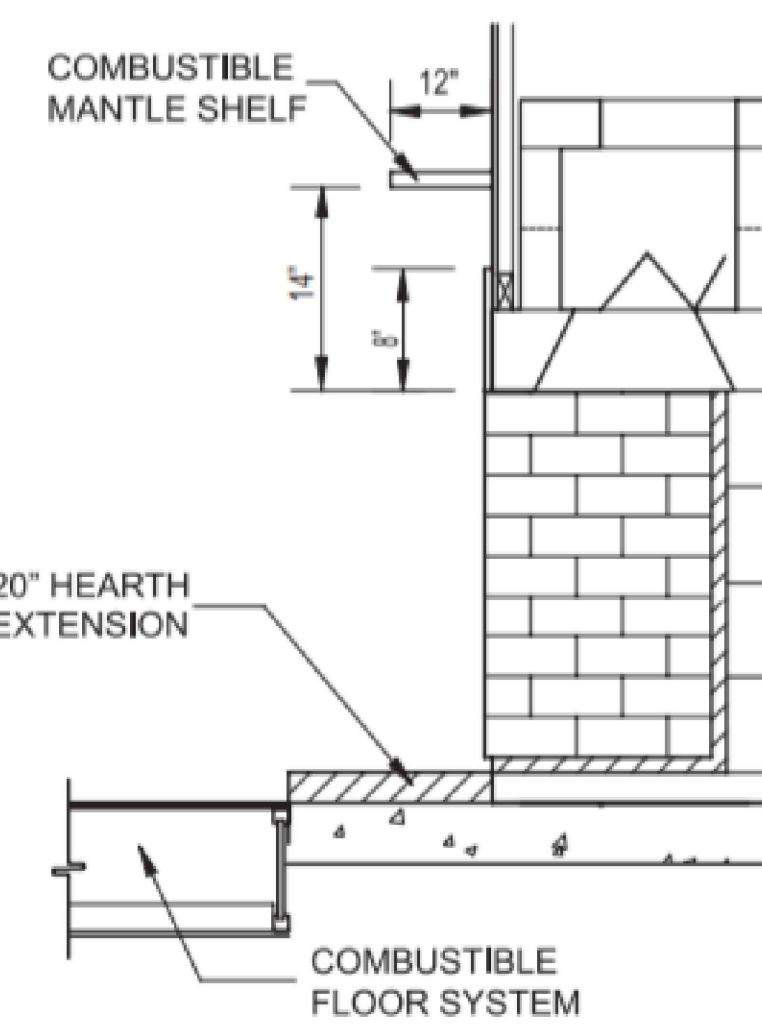

Magnum Series (All Fuel) Specifications

MANUFACTURER:

ISOKERN Fireplace and Chimney Systems, North America distribution by Earthcore Industries, LLC, Jacksonville, Florida (Telephone 800-642-2920)

PRODUCT DESCRIPTION:

Modular refractory masonry precast fireplace and chimney components.

- Designed for field assembly as a fireplace and chimney unit.
- All interlocking parts necessary for assembly of a complete firebox and smoke dome.
- Interlocking double module chimney components (DM).

MATERIALS:

- Light weight concrete of a proprietary mixture of Icelandic volcanic aggregate and cement for precast firebox, chimney block and flue liner components.
 - Compressive Strength: Firebox and Chimney Block: 972 psi.
 - Compressive Strength: Flue Liner: 1175 psi.
- Premixed (dry) EARTHCORE ADHESIVE.
 - Tensile strength: 807 psi; Compressive strength: 2460 psi.
 - Tested per ASTM C109, ASTM C307, and ANSI 118.4.
- Standard 1-1/8" thick high temperature refractory brick to line firebox interior for models 28"-48".
- Standard 1-1/8" thick high temperature refractory brick on the back wall & floor and 4" thickness of high temperature refractory brick on the sidewalls for models 60"-72".
- Standard cast iron poker-style damper (optional top mount or in-line damper available).

INSTALLATION:

- Reference manufacturer's installation instructions for standard configurations, weights, sizes and installation details.
- Suitable masonry foundation and noncombustible hearth extensions must be provided.
- Unit to be assembled on site per manufacturer's illustrated instructions.
 - Premixed EARTHCORE ADHESIVE is used at all joints between components.
 - Firebox to be lined with a minimum 1-1/8" thick rated firebrick (Models 28"-48").
 - Firebox back-wall and floor to be lined with a minimum 1-1/8" thick rated firebrick and 4" thick rated firebrick on side walls (Models 60"/72").
- A 1-1/2" minimum clearance to combustible materials is required.
- A 3" minimum clearance to insulation required.

CERTIFICATION:

- Warnock Hersey/Intertek Testing Services Report No. 632-912500; 3159656MID-008; 3082504-T1
- Magnum 60 & 72 PFS Testing Services Report No. F17-237.
- Meets or exceeds UL 103HT; UL 103; UL 127-99; UL 1777; ULC S610; ANSI 223.1.

CODE COMPLIANCE:

- SBCCI NO. 9626
- LARR NO. 25483
- NYC-MEA 241-90-E
- ICC Report NO. ESR-2316
- IBC 2006, IRC 2006, IMC 2006

NOTE: Isokern components are a natural material and slight variations in dimensions may occur. These should be no more than 1/8".



Intertek
W/N 04897
DO NOT REMOVE
OR COVER
THIS LABEL

MODULAR REFRACTORY FIREPLACE

MAGNUM: 28" 36" 42" 48"
82028 82036 82042 82048

ISOKERN

MADE IN USA
Chesapeake, VA 23323

Headquarters
Jacksonville, FL 32256

CERTIFIED TO: UL 127, ULC S610

WHI-

CLEARANCE TO COMBUSTIBLES:

SMOKE DOME FRONT AND ISOKERN CHIMNEY UNIT SIDES AND REAR	= 0 in.
COMBUSTIBLE SHEATHING ABOVE OPENING	= 1.5 in. (38mm)
TOP SHEATHING OR TRIM TO OPENING SIDES	= 8 in. (203mm)
MANTLE ABOVE OPENING	= 8 in. (203mm)
OPENING TO SIDEWALL	= 14 in. (356mm)
HEARTH EXTENSION BEYOND FRONT	= 26 in. (660mm)
HEARTH EXTENSION BEYOND SIDES	= 20 in. (508mm)
COMBUSTIBLE FLOOR (MUST USE FIRE-LITE APPLICATION)	= 12 in. (305mm)
INSULATION FROM FIREBOX	= 4 in. (102mm)
	= 3 in. (76mm)

USE SOLID WOOD FUEL OR LISTED DECORATIVE GAS VENTED OR UNVENTED APPLIANCE. ALSO FOR USE WITH LISTED METAL CHIMNEY. FIRE-LITE APPLICATION TO USE ECO-STEEL CHIMNEY ONLY.

DO NOT USE A FIREPLACE INSERT OR OTHER PRODUCTS NOT SPECIFIED FOR USE WITH THIS PRODUCT. "WARNING" THIS FIREPLACE HAS NOT BEEN TESTED FOR USE WITH GLASS DOORS. TO REDUCE THE RISK OF FIRE OR INJURY, DO NOT INSTALL GLASS DOORS. IF DOORS ARE USED, OPERATE FIREPLACE WITH DOORS FULLY OPEN. WHEN BURNING A DECORATIVE GAS APPLIANCE IN THE FIREPLACE, LOCK THE DAMPER TO THE FULLY OPEN POSITION. DO NOT OPERATE AN UNVENTED GAS LOG SET IN THIS FIREPLACE WITH THE CHIMNEY REMOVED.

SEE INSTALLATION AND OPERATING INSTRUCTIONS FOR THIS MODEL AND ICC # ESR-2316.

CONTACT BUILDING OFFICIAL PRIOR TO INSTALLATION
REFER TO INTERTEK'S DIRECTORY OF BUILDING PRODUCTS FOR DETAILED INFORMATION.

SCAN QR CODE FOR LATEST INSTALLATION MANUALS



 INDUSTRIES, L.L.C. <small>6886 Phillips Industrial Blvd. Jacksonville, FL 32256</small>	UNLESS OTHERWISE STATED, ALL DIMENSIONS ARE IN MILLIMETERS		PROJECT: 48" MAGNUM WITH FIRELITE	
	ANG. X	TOLERANCES	THIRD ANGLE PROJECTION	DESCRIPTION: GENERAL INFORMATION AND SPECIFICATIONS
LIN X			MATERIAL:	
XX X			DRAWN: K.B.H.	DATE: 9/9/2024
			APPROVED:	DATE:
			SIZE: D	SCALE: N.T.S.
			DRAWING #: 82048-FLK	REV: D
			DO NOT SCALE	SHEET 1 OF 2