

TOP

METAL-FAB 12" B-VENT PIPE (12" I.D./13" O.D.) W/ DOWN-DRAFT DIVERTER W/ DAMPER REQUIRED.

PIPE MUST TERMINATE VERTICALLY AT A MINIMUM OF EIGHTEEN FEET (18') AS MEASURED VERTICALLY FROM THE ANCHOR PLATE.

MAXIMUM CHIMNEY OFFSET ANGLE IS FORTY-FIVE DEGREES OFF OF VERTICAL. ONLY ONE OFFSET (2 ELBOWS) ALLOWED.

FRAME OPENINGS TO 15" X 15" CLEAR TO MAINTAIN MIN. 1" CLEARANCE TO COMBUSTIBLES.

DAMPER CABLE MUST BE SECURED TO THE DAMPER LEVER. WHEN DAMPER IS CLOSED, THE CABLE SHOULD BE TAUT AND THE LEVER TURNED ALL THE WAY TO THE RIGHT.

CENTER THE NVT-1 IN POSITION UNDER THE DAMPER BEAM AND MARK LOCATION OF PILOT HOLES. NVT-1 SHOULD BE FLUSH WITH FRONT OF FIREBOX/ DAMPER BEAM.

PRE-DRILL USING Ø 3/16" DRILL APPROXIMATELY 2" INTO ISOKERN.

ROUTE WIRES ROUTED TOWARDS SIDE OF FIREBOX WHERE GAS VALVE IS LOCATED.

SECURE NVT-1 INTO UNDERSIDE OF DAMPER BEAM VIA (8X) 1/4 X 1-3/4" TAPCON.

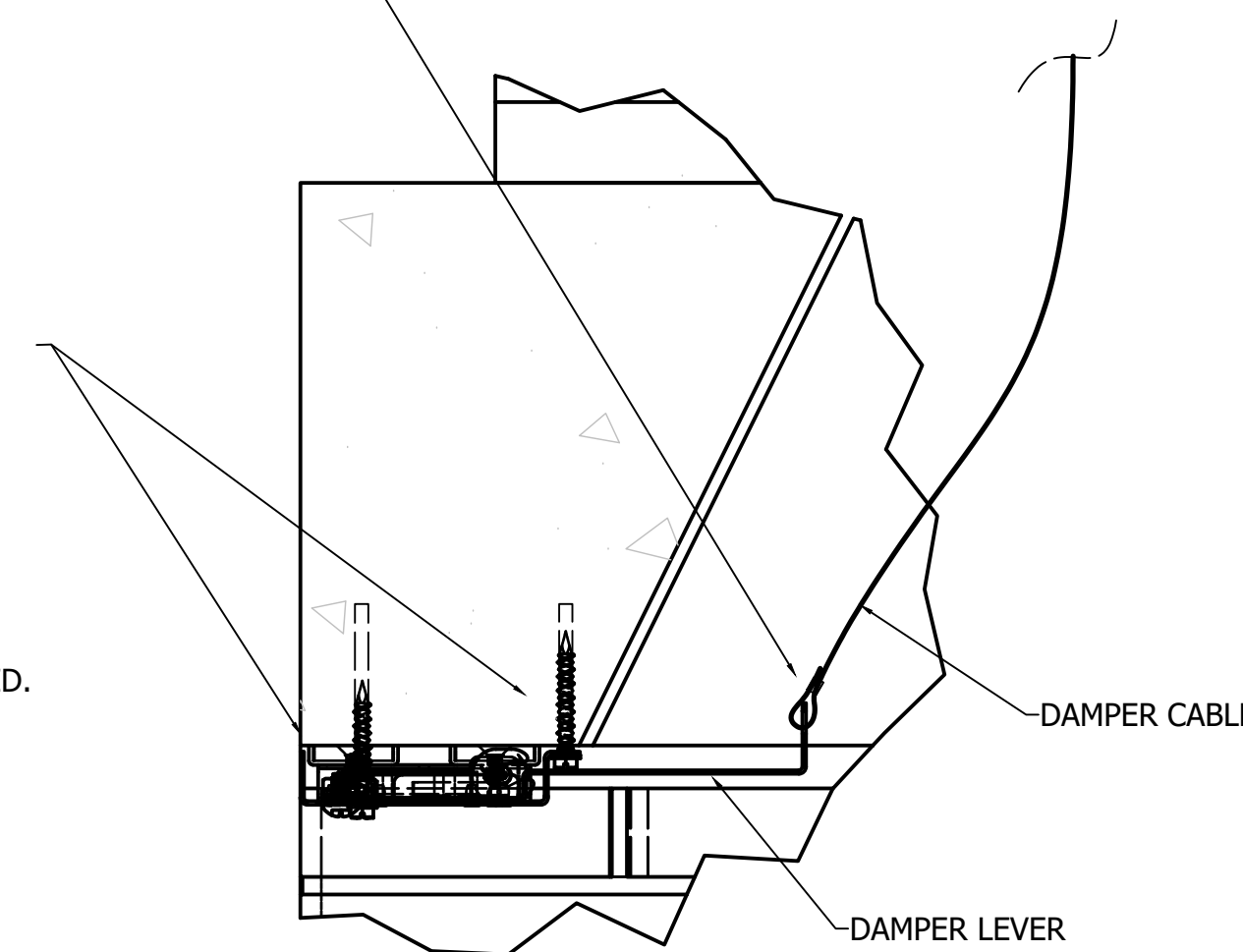

DETAIL A  
SCALE: N.T.S.

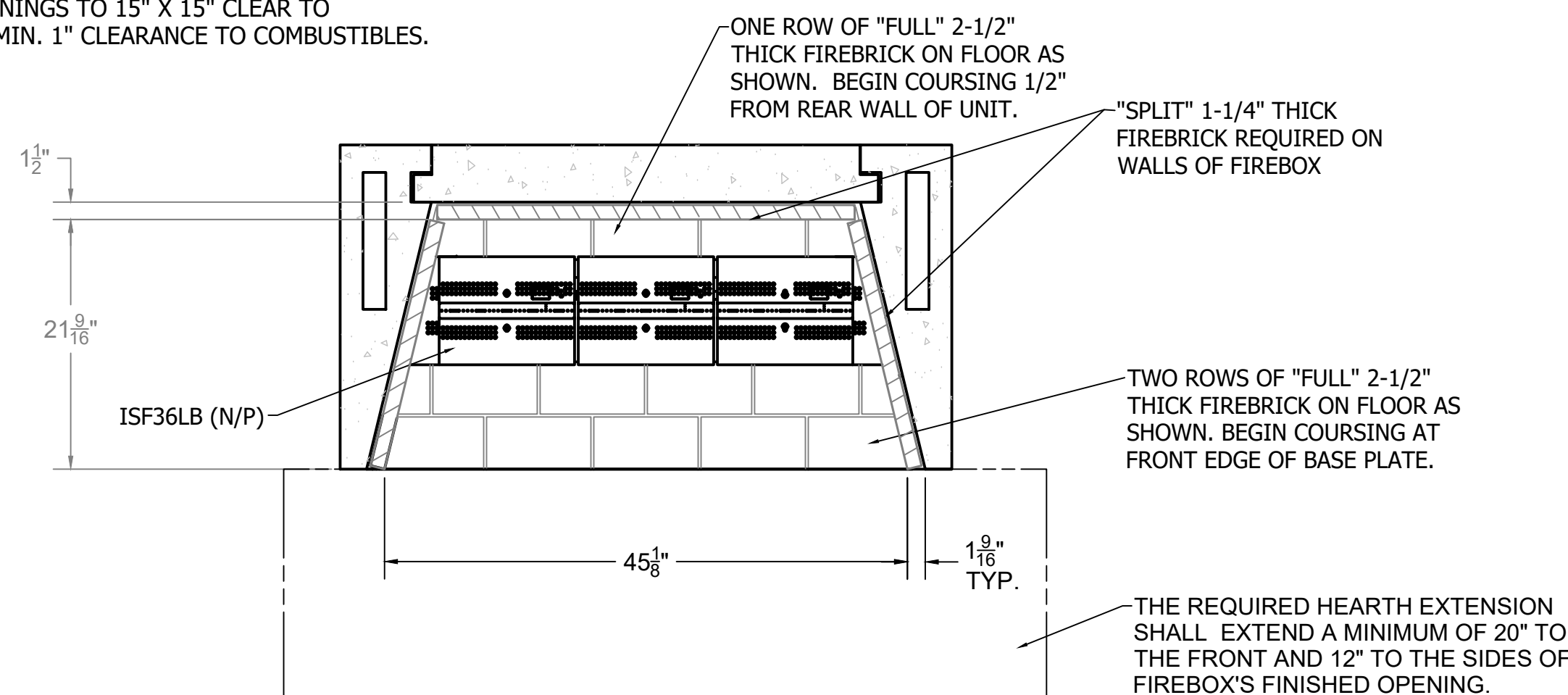

SECTION A-A

ONE ROW OF "FULL" 2-1/2" THICK FIREBRICK ON FLOOR AS SHOWN. BEGIN COURSING 1/2" FROM REAR WALL OF UNIT.

"SPLIT" 1-1/4" THICK FIREBRICK REQUIRED ON WALLS OF FIREBOX

TWO ROWS OF "FULL" 2-1/2" THICK FIREBRICK ON FLOOR AS SHOWN. BEGIN COURSING AT FRONT EDGE OF BASE PLATE.

THE REQUIRED HEARTH EXTENSION SHALL EXTEND A MINIMUM OF 20" TO THE FRONT AND 12" TO THE SIDES OF FIREBOX'S FINISHED OPENING.

METAL-FAB 12" B-VENT PIPE (12" I.D./13" O.D.)

FRAME OPENINGS TO 15" X 15" CLEAR TO MAINTAIN MIN. 1" CLEARANCE TO COMBUSTIBLES.

NVT-2 ANCHOR PLATE WITH DIVERTER AND DAMPER

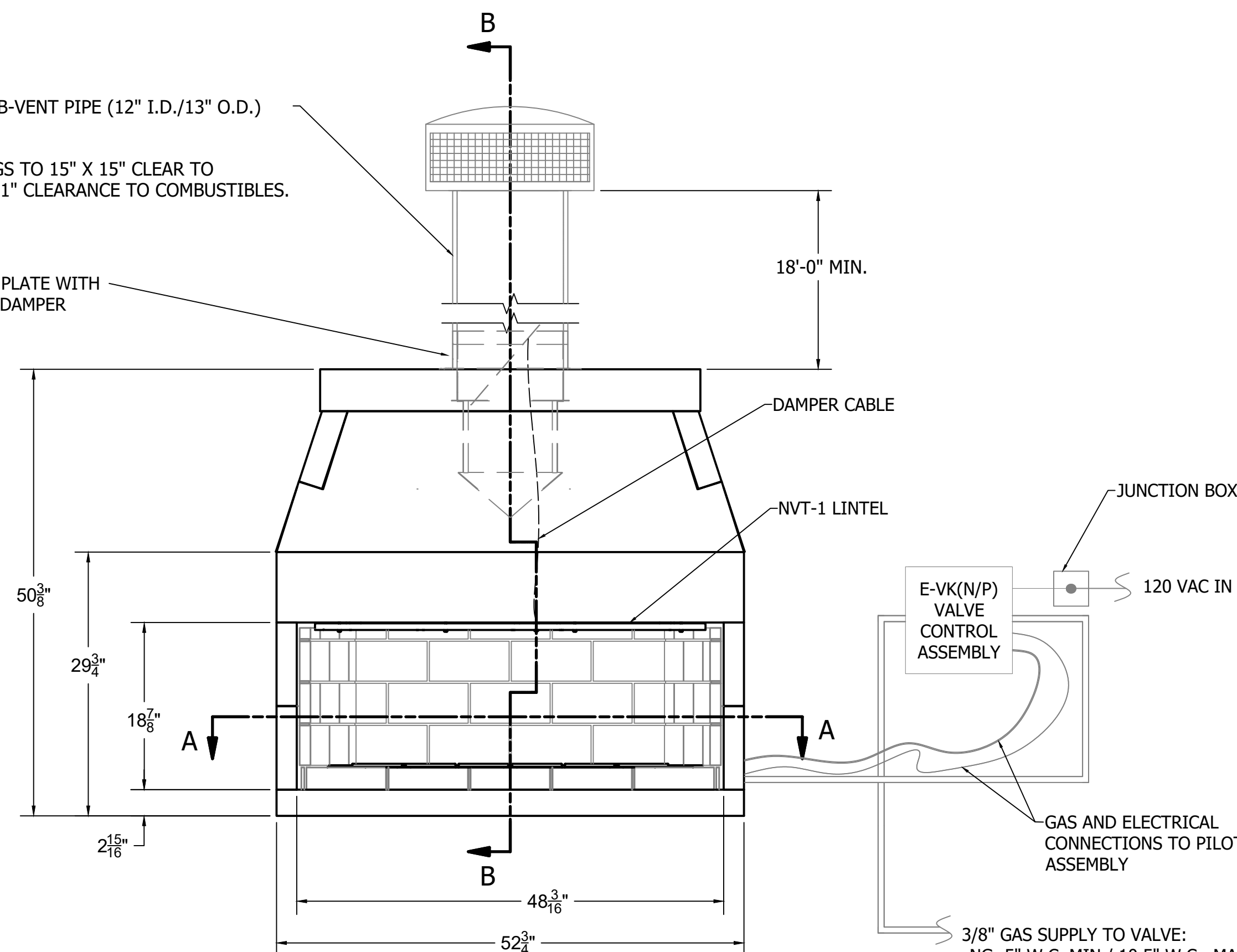

FRONT

3/8" GAS SUPPLY TO VALVE:  
•NG: 5" W.C. MIN./ 10.5" W.C. MAX.  
•LP: 11" W.C. MIN./ 13" W.C. MAX.

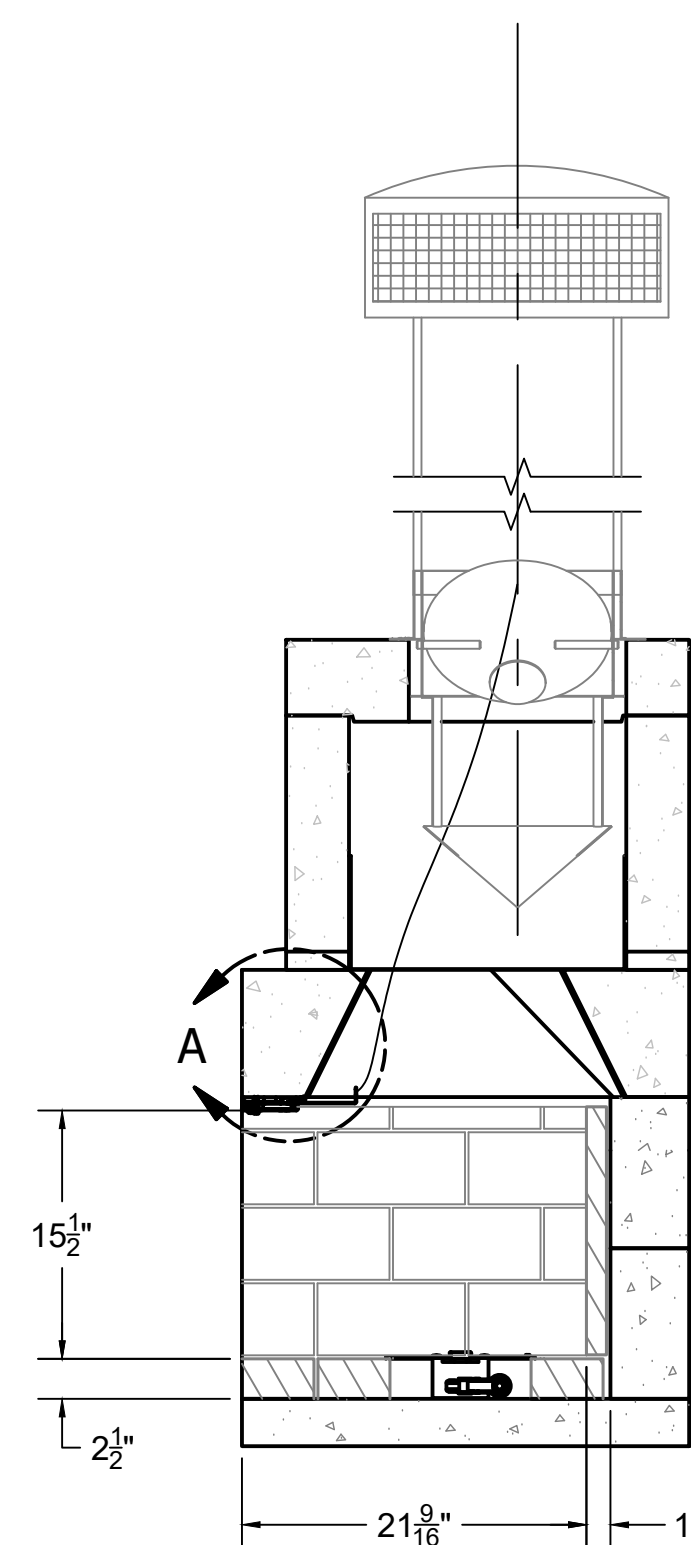

SECTION B-B

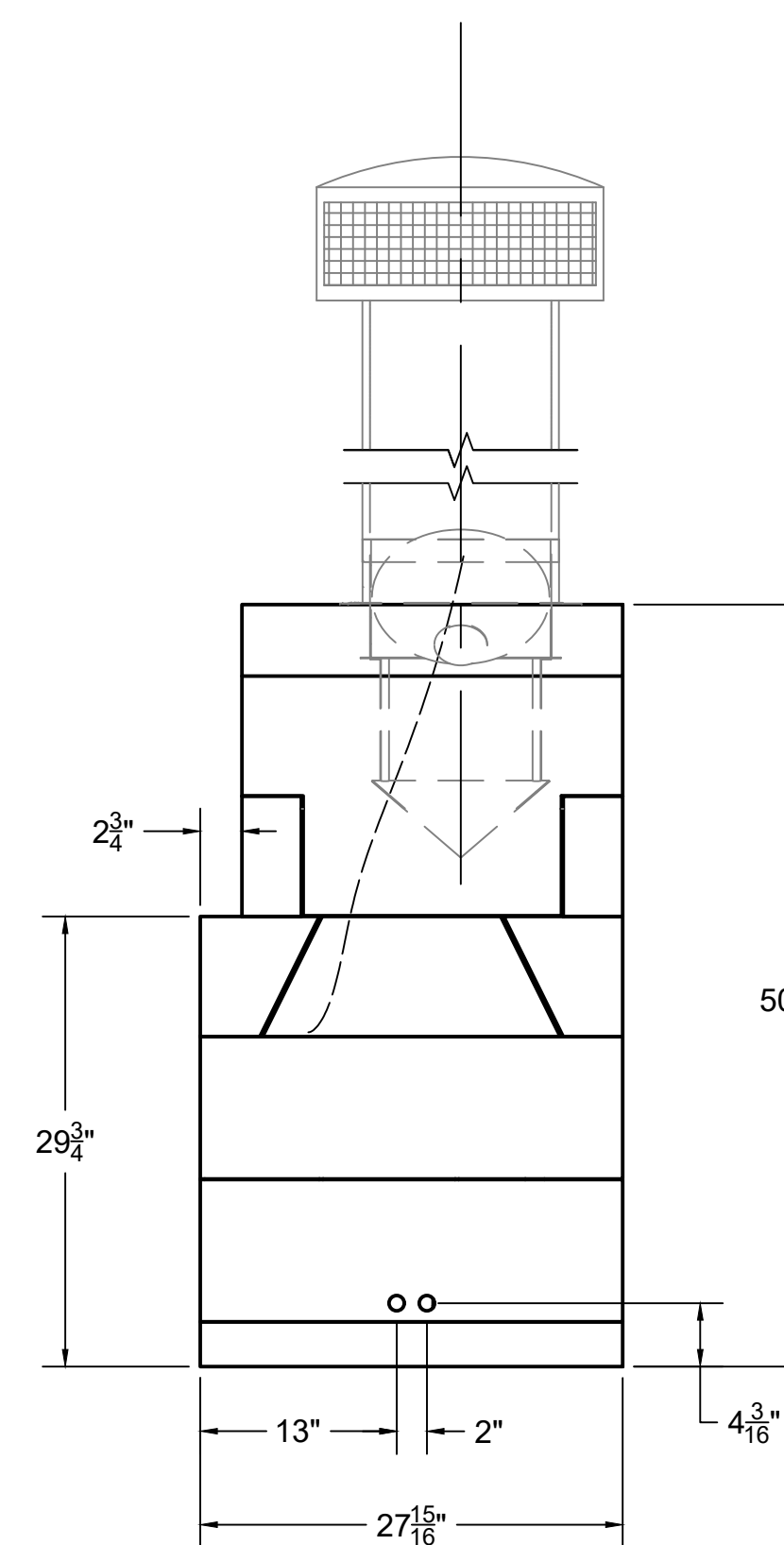

RIGHT

ISOMETRIC VIEW (N.T.S.)

METAL-FAB 12" B-VENT PIPE (12" I.D./13" O.D.) W/ DOWN-DRAFT DIVERTER W/ DAMPER REQUIRED.  
PIPE MUST TERMINATE VERTICALLY AT A MINIMUM OF EIGHTEEN FEET (18') AS MEASURED VERTICALLY FROM THE ANCHOR PLATE.  
MAXIMUM CHIMNEY OFFSET ANGLE IS FORTY-FIVE DEGREES OFF OF VERTICAL. ONLY ONE OFFSET (2 ELBOWS) ALLOWED.  
FRAME OPENINGS TO 15" X 15" CLEAR TO MAINTAIN MIN. 1" CLEARANCE TO COMBUSTIBLES.

NVT-1 LINTEL

1-1/4" THICK FIREBRICK ON SIDE AND REAR WALLS

2-1/2" THICK FIREBRICK ON FLOOR

ISF36LB(N/P)

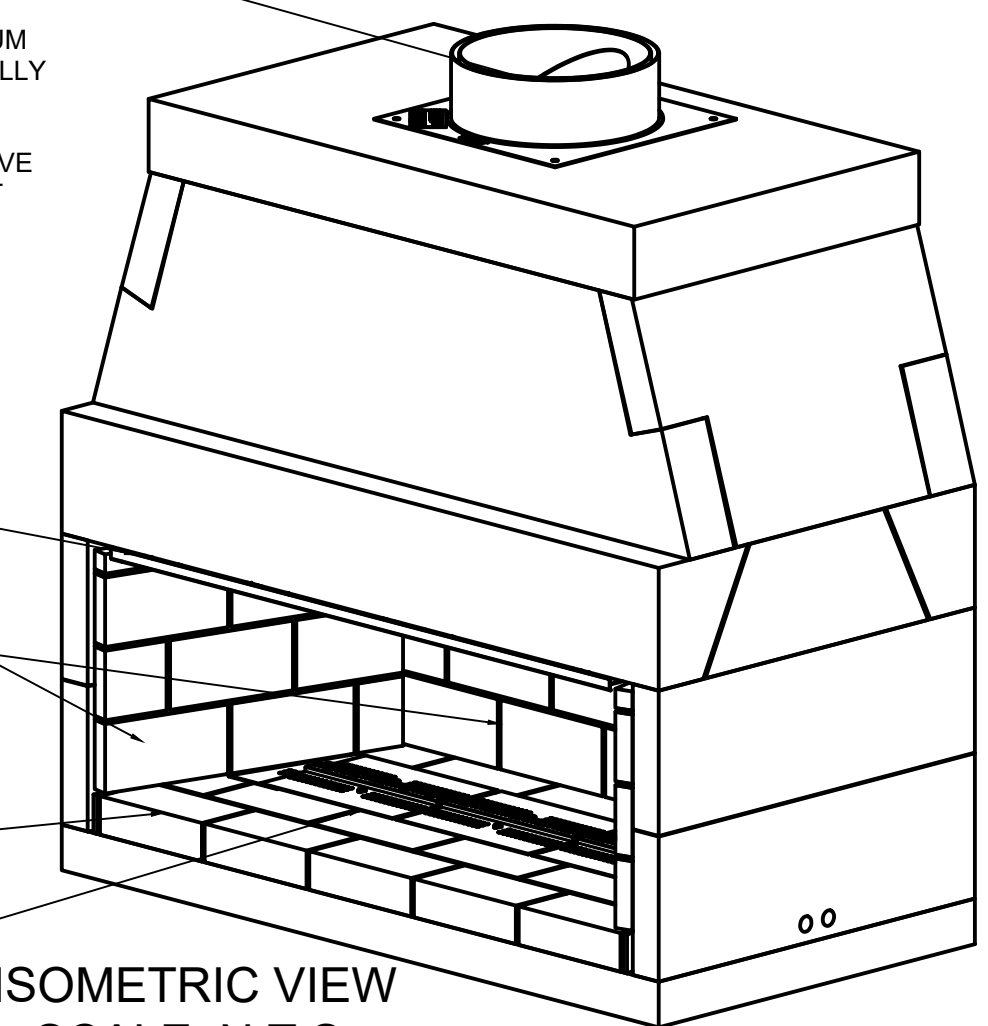

ISOMETRIC VIEW  
SCALE: N.T.S.

\*REQUIRED E-VK(N/P) VALVE ASSEMBLY NOT SHOWN

		UNLESS OTHERWISE STATED, ALL DIMENSIONS ARE IN INCHES UNDESIGNED TOLERANCES ANG. A ± LIN. X ± XX ± XXX ±		THIRD ANGLE PROJECTION 		PROJECT: 4' MAXIMUS LINEAR DESCRIPTION: FIREPLACE CONSTRUCTION DOCUMENT W/ NVT SAFETY SYSTEM MATERIAL: E.C. PUMICE MIXTURE DRAWN: K.B.H. DATE: 10/1/2024		SIZE: D SCALE: 1"=1'-0" DRAWING #: 82L48-NVT SHEET 1 OF 2	
--	--	---	--	----------------------------	--	--	--	--	--

ISOKERN COMPONENT AND ACCESSORIES LIST		
PART #	QTY.	DESCRIPTION
82L48	1	48" MAXIMUS LINEAR FIREPLACE
---	1	6"x6"x1/2" STEEL ANGLE, 85-7/8" LONG (NOT SUPPLIED BY EARTHCORE, SOURCE LOCALLY)
NVT-1	1	NVT-1 HIGH TEMP LINTEL, 48" - 72" MODELS
NVT-2	1	12" B-VENT ANCHOR PLATE W/ DRAFT DIVERTER AND DAMPER
ISF36LB	1	ISOFLAMES 36" LINEAR BURNER ASSEMBLY (N: NATURAL GAS/ P: PROPANE)
E-VK(N/P)	1	GAS VALVE CONTROL BOX (N: NATURAL GAS/ P: PROPANE)

GENERAL NOTES

- THE ISOKERN 48" MAXIMUS LINEAR FIREPLACE IS A TOP-VENTED, GAS ONLY FIREPLACE THAT IS APPROVED FOR USE ONLY WITH THE ISOFLAMES LINEAR BURNER SYSTEM AS SHOWN IN THIS DRAWING (ISF36LB(N/P)). USAGE OF ANY OTHER BURNER IN THIS FIREPLACE IS PROHIBITED AND WILL ABSOLVE EARTHCORE/ ISOKERN OR ANY DIVISION THEREOF FOR ANY INCIDENTAL OR CONSEQUENTIAL DAMAGES OR EXPENSES ARISING OUT OF THE USE OF THIS FIREPLACE.
- THIS FIREPLACE'S BURNER SYSTEM (ISF36LB N/P) COMES WITH A GAS CONTROL VALVE ASSEMBLY (E-VK(N/P)) THAT INCLUDES AN AUTOMATIC DRAFT AND SAFETY SYSTEM. BURNER OPERATION IS INTERLOCKED INTO THE NVT-1 AND NVT-2 SAFETY SYSTEM.
- THIS APPLIANCE IS ONLY FOR USE WITH THE TYPE OF GAS INDICATED ON THE BURNER RATING PLATE. VERIFY GAS SUPPLY AND BURNER/ VALVE ARE OF SAME TYPE PRIOR TO INSTALLATION.
- ALL NATURALLY VENTING APPLICATIONS OF THE MAXIMUS LINEAR SERIES SHALL BEGIN WITH THE NVT-2 (12" B-VENT ANCHOR PLATE WITH DRAFT DIVERTER AND DAMPER).
- THE EXHAUST FLUE GASES ARE TO BE VENTED THROUGH THE TOP OF THE UNIT WITH LISTED 12" B-VENT PIPING. A MINIMUM OF EIGHTEEN FEET (18') AS MEASURED VERTICALLY FROM THE ANCHOR PLATE TO THE CHIMNEY CAP IS REQUIRED. MAXIMUM CHIMNEY OFFSET ANGLE IS FORTY-FIVE DEGREES OFF OF VERTICAL. ONLY ONE OFFSET (2 ELBOWS) ALLOWED. CHIMNEY MUST TERMINATE VERTICALLY. THE TWELVE-INCH (12") DIAMETER, DOUBLE WALL B-VENT PIPE AND LISTED VENT CAP ARE NOT SUPPLIED BUT ARE REQUIRED FOR PROPER OPERATION OF ALL MAXIMUS LINEAR.
  - NOTE: IF THE ABOVE CONDITIONS ARE NOT PRESENT, THE XVENTIO-MERIDIAN MECHANICAL DRAFT SYSTEM IS REQUIRED
- INSTALL AND SUPPORT B-VENT PIPE TO ALL MANUFACTURER SPECIFICATIONS. ENSURE MIN. 1" CLEARANCE TO COMBUSTIBLES IS KEPT AT ALL TIMES.
- THE MAXIMUS LINEAR SERIES FIREPLACES SHALL BE INSTALLED WITH THE MINIMUM CLEARANCES TO COMBUSTIBLES AS LISTED BELOW:
  - UNIT FRONT: 0"
  - SIDES AND REAR: 1.5"
  - COMBUSTIBLE SHEATHING ABOVE OPENING TOP: 8"
  - SHEATHING OR TRIM TO OPENING SIDES: 8"
  - MANTEL ABOVE OPENING: 12"
  - OPENING TO SIDEWALLS: 24"
  - HEARTH EXTENSION BEYOND FRONT: 20"
  - HEARTH EXTENSION BEYOND SIDES (FINISHED): 12"
  - COMBUSTIBLE FLOOR: 0" (MUST USE ISOKERN BASE PLATE, "FULL" 2-1/2" FIREBRICK, AND ISOFLAMES LINEAR BURNER/ VALVE)
  - INSULATION FROM FIREBOX (UNSHIELDED): 3"
- ENSURE A 120VAC/ 15A OUTLET IS PROVIDED FOR E-VKN/ E-VKP GAS VALVE FOR ISOFLAMES LINEAR BURNER. CONTROLS SHALL BE LOCATED IN ACCESSIBLE LOCATION.
- ALL ACCESSORIES/ EQUIPMENT INSTALLED WITH THIS FIREPLACE TO BE INSTALLED ACCORDING TO MANUFACTURER'S SPECIFICATIONS.
- DRAWINGS ARE FOR DESIGN PURPOSES ONLY AND ARE THE SOLE PROPERTY OF EARTHCORE INDUSTRIES. ANY REPRODUCTION OR UNAUTHORIZED USE IS STRICTLY PROHIBITED.
- EARTHCORE/ ISOKERN OR ANY DIVISION THEREOF SHALL NOT BE HELD LIABLE FOR ANY INCIDENTAL OR CONSEQUENTIAL DAMAGES OR EXPENSES ARISING OUT OF THE USE OF THE FIREPLACES OR CHIMNEY SYSTEMS.
- ALWAYS CHECK LOCAL BUILDING CODES GOVERNING FIREPLACES AND FIREPLACE INSTALLATIONS.

### Rough Framing Dimensions

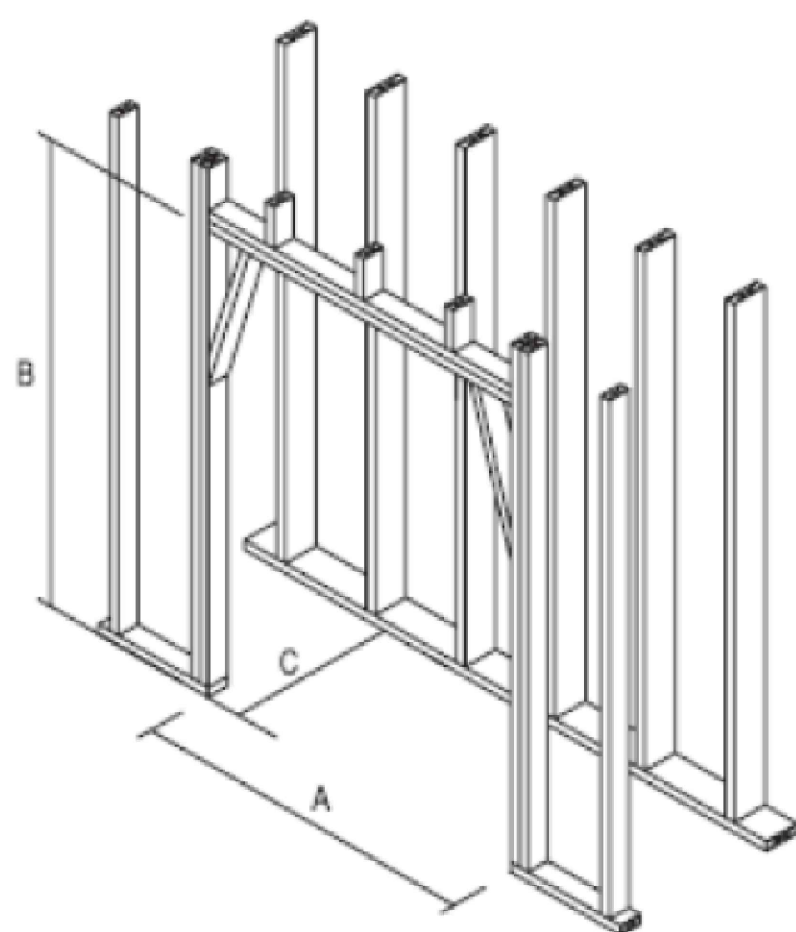

TYPICAL INSTALLATION FRAMING DIMENSIONS			
Model #	A - Width	B - Height	C - Depth
82L48	56"	51"	29-1/2"
82L60	77"	51"	29-1/2"
82L72	89"	51"	29-1/2"
82L96	112"	51"	29-1/2"
82L120	135"	51"	29-1/2"

**NOTES:**

- "B" includes the required 3" thick base plate.
- If the Maximus Linear installation is to be elevated, this "Raised hearth" installation will require additional rough opening height at "B" that is equal to the height of the raised hearth.
- Rough framing dimension for depth "C" allows for the required 1-1/2" clearance at the back of the fireplace. Note that this 29-1/2" is typically used on interior walls that do not have insulation present.

**IMPORTANT:** Unless the insulation on an exterior wall is installed behind plywood sheathing, a depth of 31" is often used to account for the required 3" clearance to insulation. Even with this increased distance, the installer should be aware that spray foam insulation may expand past the face of the stud wall and will require trimming prior to firebox installation to maintain the required 3" clearance. It is important that any insulation that is not installed behind sheathing shall be installed in such a manner that it cannot fall on the firebox and encroach on this clearance.

### Firebrick Installation - Maximus Linear Fireplace

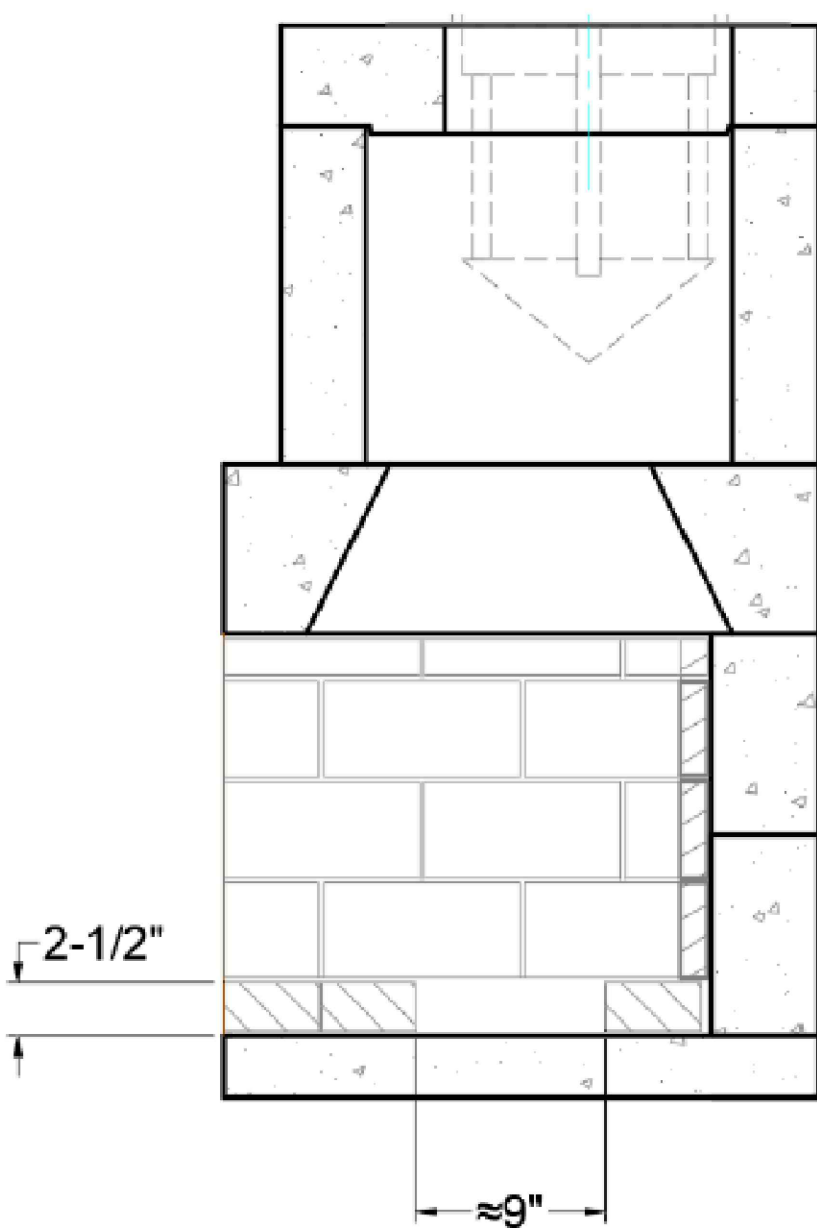

- Starting approximately 1/2" from the rear of the firebox, lay one course of "full" sized firebrick on floor. Ensure a gap of approximately 1/2" is kept between firebrick and sidewall to allow for expansion.
- Lay two courses of "full" sized firebrick so that the leading edge of the coursing is aligned with opening of the firebox. Ensure a gap of approximately 1/2" is kept between firebrick and sidewall to allow for expansion.
- Apply "split" firebrick to the rear wall of the unit. Ensure approximately 1/2" gap is kept between firebrick and sidewall, as well as an 1/4" gap is kept between firebrick and damper beam assembly to allow for expansion.
- Starting at the front edge of the unit's sidewall, apply "split" firebrick to the side wall of the unit. Ensure approximately 1/2" gap is kept between firebrick and damper beam/damper block assembly to allow for expansion.
- Repeat on opposite side wall.

**IMPORTANT:**

Ensure that the required holes for the Isoflames Linear burner's 3/8" gas supply line and pilot assembly gas and electrical connections are drilled prior to firebrick installation. **DO NOT COVER THESE AREAS WITH FIREBRICK!**

### Clearance to Combustible Trim

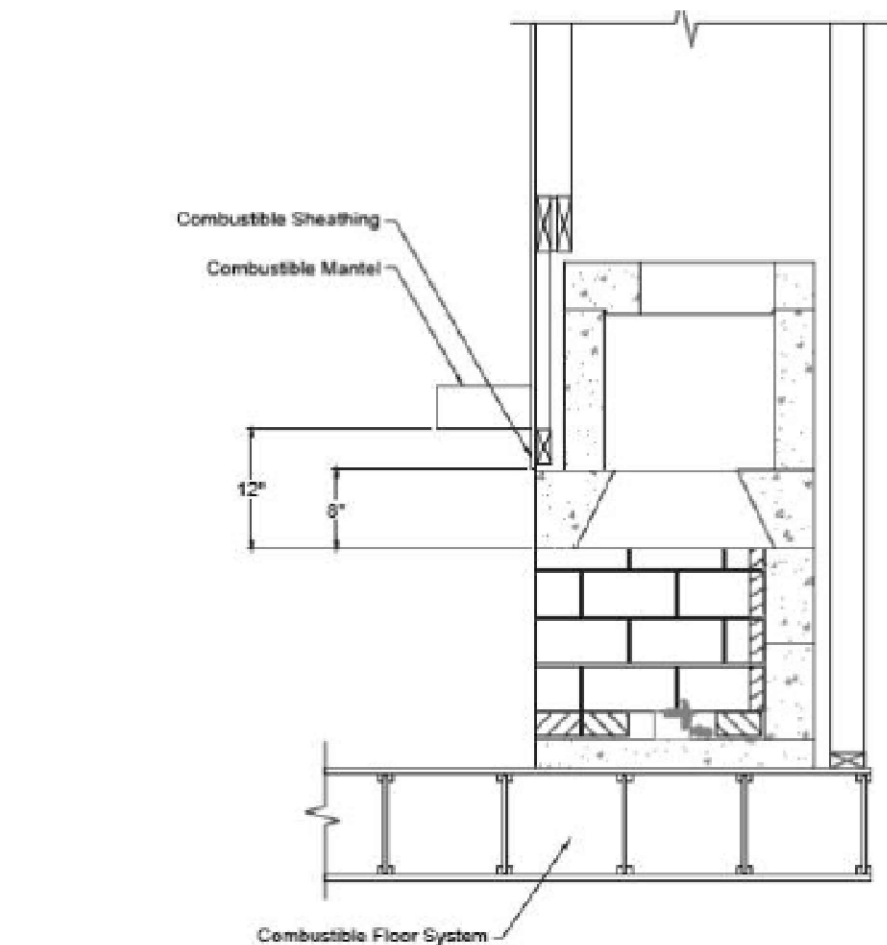

**NOTE:** "Clearance to Combustible Trim" are those distances required to ensure that a fireplace mantel or facing will not catch fire. In most cases the distances should also be adequate to prevent any discoloration or warping due to heat. However, each installation presents a unique and completely different set of circumstances involving many variables.

These variables include paint or finish composition, previous exposure to heat, methods and quality of construction, air flow patterns, etc. Because of these variables, the manufacturer does not guarantee that heat warping, or discoloration will never occur.

**MANTEL AND MANTEL SHELF CLEARANCES:**

Maximus Linear units are designed to be installed so that the rough front face(s) of the Isokern firebox and smoke dome sit flush with the face of the rough framing members that create the room wall finish.

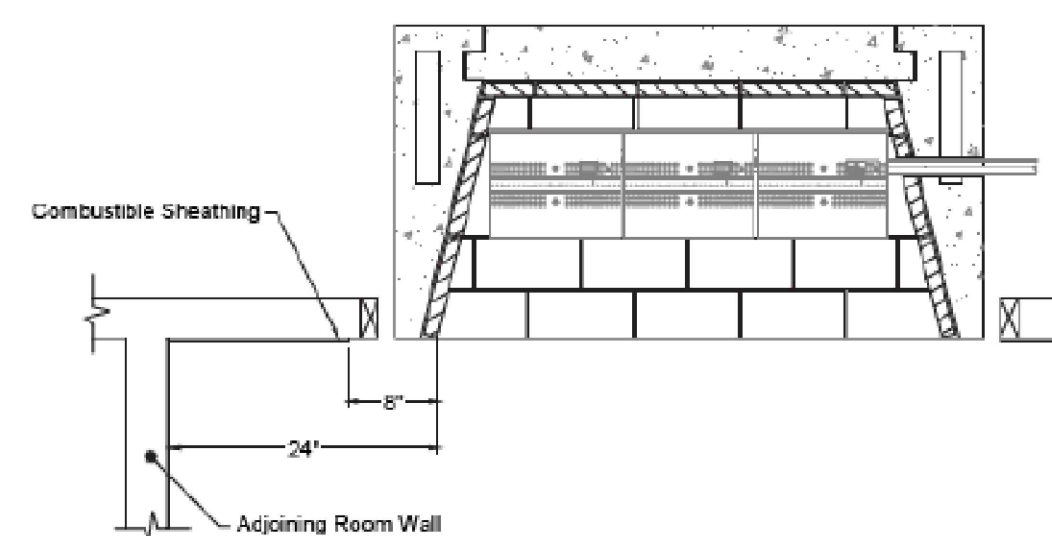

All combustible trim projecting less than one-and one-half inch (1-1/2") from this plane must be kept a minimum of eight inches (8") from the sides/top of the firebox openings.

All combustible trim projecting more than one and one-half inch (1-1/2") must be kept a minimum of twelve inches (12") from the fireplace opening.

Parts of the combustible mantel assembly located along the sides of the fireplace opening, which project more than one- and one-half inches (1-1/2") from the face of the fireplace, shall have additional clearance equal to that of the projection.

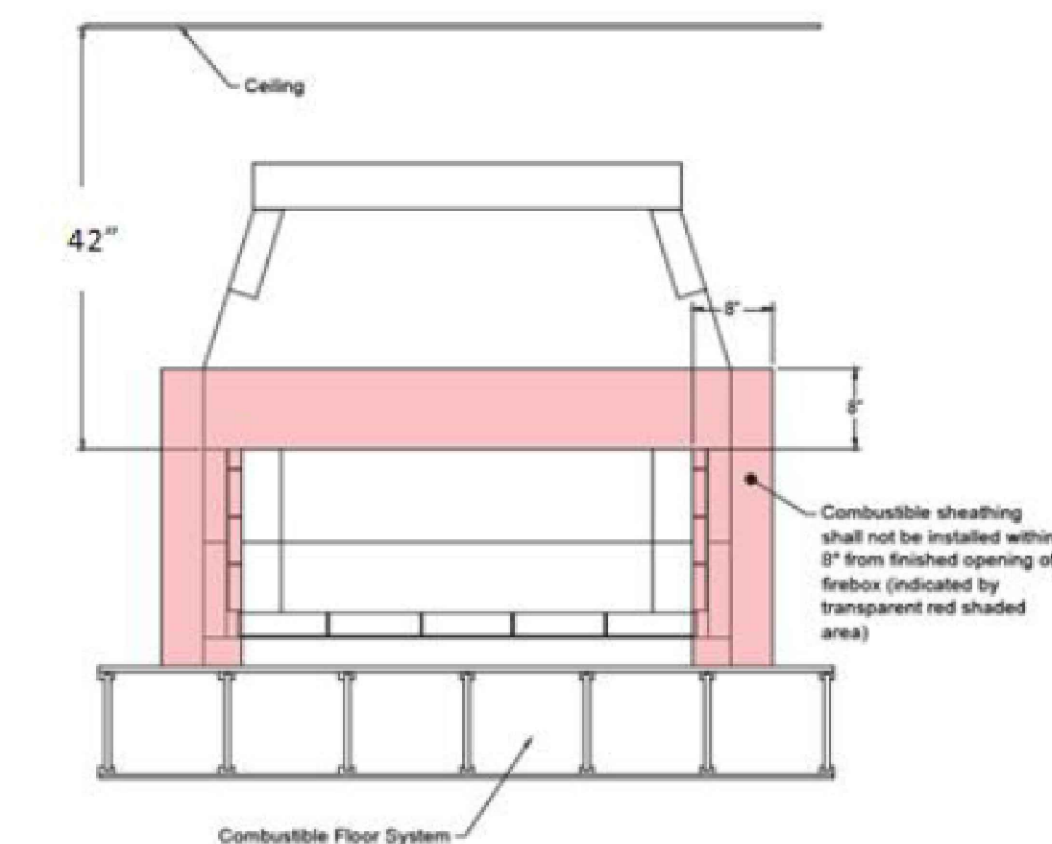

Parts of the combustible mantel assembly located above and projecting more than one- and one-half inches (1-1/2") from the fireplace opening shall not be placed less than twelve inches (12") from the top of the fireplace opening.

**ADJOINING WALLS:**

Side walls and walls to rooms adjoining the Isokern fireplace installation cannot be closer than twenty-four inches (24") to the finished fireplace opening.

**CEILING:**

The minimum clearance from the top of the fireplace opening to a ceiling is forty-two inches (42").

## Maximus Linear Series (Gas Only-Natural Vent) Specifications

**MANUFACTURER:**

ISOKERN Fireplace and Chimney Systems, North America distribution by Earthcore Industries, LLC, Jacksonville, Florida (Telephone 800-642-2920)

**PRODUCT DESCRIPTION:**

- Modular refractory masonry precast fireplace and chimney system.
- Designed for field assembly as a fireplace and B-vent chimney system.
  - All interlocking parts necessary for assembly of a complete firebox and smoke dome (Glass-Front Kit installation option is only available on Maximus Linear series using mechanical draft).
  - Isoflames Linear Burner and Valve system (per installation manual)
  - NVT-1 and NVT-2 safety system
  - 12" B-vent chimney flue (per installation manual)

**MATERIALS:**

- Light weight concrete of a proprietary mixture of Icelandic volcanic aggregate and aluminum cement for precast firebox, chimney block and flue liner components.
  - Compressive Strength: Firebox Block: 972 psi.
- Premixed (dry) EARTHCORE ADHESIVE.
  - Tensile strength: 807 psi; Compressive strength: 2460 psi.
  - Tested per ASTM C109, ASTM C307, and ANSI 118.4.
- Standard 1-1/8" high temperature refractory brick to line firebox interior walls.
- Standard 2-1/2" high temperature refractory brick to line firebox floor.

**INSTALLATION:**

- Reference manufacturer's installation instructions for standard configurations, weights, sizes and installation details.
- Suitable masonry foundation or structural wood floor system must be provided.
- Non combustible hearth extensions must be provided.
- Unit to be assembled on site per manufacturer's illustrated instructions.
  - Premixed EARTHCORE ADHESIVE is used at all joints between components.
  - Firebox to be lined with a minimum 1-1/8" rated firebrick on the walls and 2-1/2" rated firebrick on floor (trough created in firebrick floor for Isoflames Linear Burner installation).
  - A 1-1/2" minimum clearance to combustible materials is required for firebox side and back-walls.
  - A 3" minimum clearance to insulation required.
- The Maximus Linear shall be installed only with the approved Isoflames Linear Burner and Valve System as detailed in the instruction manual.
- Installation must use the NVT-1 and NVT-2 safety system interlocked with Isoflames Linear Burner.
- Installation must use 12" B-vent pipe as detailed in the instruction manual. (NVT-2 Anchor Plate with Draft-Diverter and Damper and NVT-1 Lintel required).
- Minimum of eighteen feet (18') of pipe as measured vertically from the anchor plate to the chimney cap is required.
- Maximum chimney offset angle is forty-five degrees off of vertical.
- Only one offset (2 elbows) allowed.
- Chimney must terminate vertically.
  - NOTE: if the above conditions (F-K) are not present, the xventiso-meridian mechanical draft system is required

**CERTIFICATION:**

- PFS Corporation, PFS Report No. F19-161
- Meets or exceeds ANSI Z 21.50-2014, CSA 2.22-2014

**CODE COMPLIANCE:**

- ICC NO. ESR 4873

**NOTE:** Isokern components are a natural material and slight variations in dimensions may occur. These should be no more than 1/8".

### WEIGHTS AND LOAD CALCULATIONS

Total dead load amounts include (but are not necessarily limited to) the following items and their corresponding weight estimates as listed below:

- Isokern Maximus Linear- Open Front unit weights:
  - Maximus Linear Open Front - 48: 1,275 lbs. (no burner, flue, or accessories)
  - Maximus Linear Open Front - 60: 1,720 lbs. (includes steel angle; but no burner, flue, or accessories)
  - Maximus Linear Open Front - 72: 1,990 lbs. (includes steel angle; but no burner, flue, or accessories)
  - Maximus Linear Open Front - 96: 2,450 lbs. (includes steel angle; but no burner, flue, or accessories)
  - Maximus Linear Open Front - 120: 2,997 lbs. (includes steel angle; but no burner, flue, or accessories)
- Approximate weight of glass media: 100 lbs.
- Fire brick and Adhesive: 350 lbs. - 1800 lbs. depending on brick size and pattern
- Facing material: per general contractor
- B-Vent metal flue: per manufacturer and installation requirements

The floor area for each model is as follows:

- Maximus Linear Open Front - 48: @ 53" x 28" = 10.3 sq. ft.
- Maximus Linear Open Front - 60: @ 73-1/2" x 28" = 14.3 sq. ft.
- Maximus Linear Open Front - 72: @ 85-3/4" x 28" = 16.67 sq. ft.
- Maximus Linear Open Front - 96: @ 108-1/4" x 28" = 21.04 sq. ft.
- Maximus Linear Open Front - 120: @ 131-3/4" x 28" = 25.62 sq. ft.

Earthcore is not responsible for structural floor support details for this fireplace system. Unless otherwise noted all floor framing drawings in this manual are merely illustrations to indicate the presence of an underlying floor system. Consult your local structural engineer for proper floor system design, sizing, and specifications.



**ISOKERN LINEAR GAS FIREPLACE**  
LISTED VENTED GAS FIREPLACE PER ANSI Z21.50 - 2019  
CSA 2.22-2019

**NOT FOR USE WITH SOLID FUEL**

SERIAL NO: L000001 MODEL #  82L48  82L72  82L60  82L96  82L120

FOR USE WITH PROPANE (LP) OR NATURAL GAS. SEE GAS IDENTIFYING TAG ON BURNER

- 82L48 NATURAL GAS MAX BTU 54,000; PROPANE MAX BTU 48,000
- 82L60 NATURAL GAS MAX BTU 72,000; PROPANE MAX BTU 64,000
- 82L72 NATURAL GAS MAX BTU 90,000; PROPANE MAX BTU 80,000
- 82L96 NATURAL GAS MAX BTU 108,000; PROPANE MAX BTU 96,000
- 82L120 NATURAL GAS MAX BTU 110,000; PROPANE MAX BTU 105,000

\*See Burner Rating Plate For Additional Information

MANIFOLD PRESSURE: PROPANE (LP): 10" WATER COLUMN; NATURAL GAS: 3.5" WATER COLUMN  
MINIMUM PERMISSIBLE GAS SUPPLY PRESSURE FOR PURPOSE OF INPUT ADJUSTMENT:  
PROPANE (LP): 11" WATER COLUMN; NATURAL GAS: 5" WATER COLUMN

ELECTRICAL RATING: UNIT: ELECTRONIC 1 PH 60 HZ 120 VOLTS LESS THAN 5 AMPS	CLEARANCE TO COMBUSTIBLES:	
	Open Front Only	Glass Front Only
UNIT FRONT	= 0in.	= 0in.
UNIT SIDES AND REAR	= 1.5in.	= 1.5in.
COMBUSTIBLE SHEATHING ABOVE OPENING	= 8in.	= 0in.
TOP SHEATHING OR TRIM TO OPENING SIDES	= 8in.	= 0in.
MANTEL ABOVE OPENING	= 12in.	= 0in.
INSULATION FROM FIREBOX	= 3in.	= 3in.

**CAUTION: THIS APPLIANCE IS ONLY FOR USE WITH THE TYPE OF GAS INDICATED ON THE RATING PLATE. THIS APPLIANCE IS NOT CONVERTIBLE FOR USE WITH OTHER GASES. UNLESS A CERTIFIED KIT IS USED.**

This appliance must be installed in accordance with local codes, if any, if none, follow the current ANSI Z223.1/NFPA 54 or CSA B149.1

EARTHCORE INDUSTRIES HEADQUARTERS  
JACKSONVILLE, FL 32256

### E-VK(N/P) VALVE LOCATION

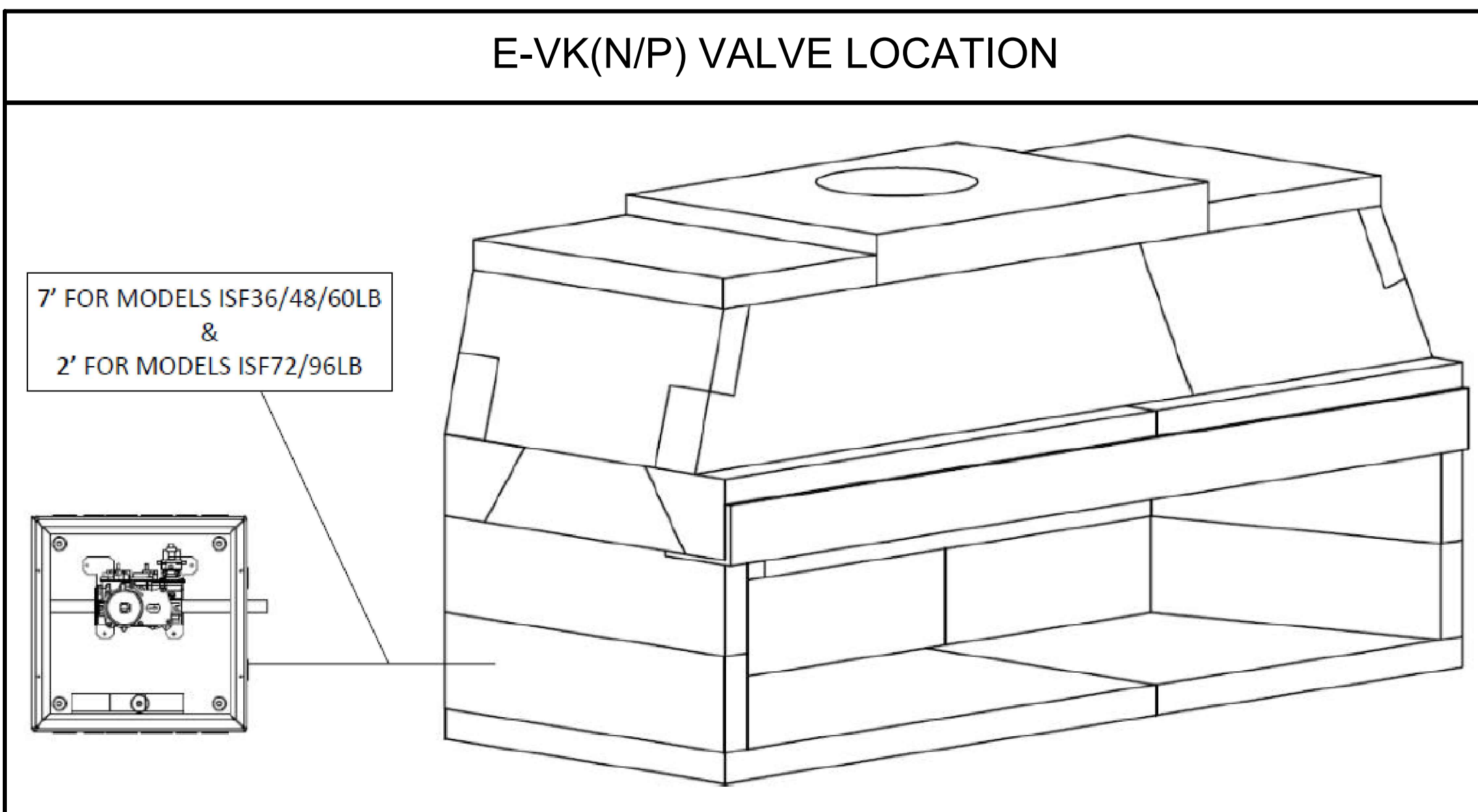

SCAN QR CODE FOR LATEST INSTALLATION MANUALS



UNLESS OTHERWISE STATED, ALL DIMENSIONS ARE IN INCHES		PROJECT: <b>4' MAXIMUS LINEAR</b>	
UNSPECIFIED TOLERANCES:	THIRD ANGLE PROJECTION	DESCRIPTION: GENERAL INFORMATION AND SPECIFICATIONS	
ANG. A ±		MATERIAL:	
LIN. XX ±		DRAWN: K.B.H.	DATE: 10/1/2024
XXX ±		APPROVED:	DATE:
EARTHCORE INDUSTRIES, L.L.C.		SIZE: <b>D</b>	SCALE: N.T.S.
		DRAWING #: 82L48 - NVT	REV: 2
		DO NOT SCALE	SHEET 2 OF 2