

Isokern® MAGNUM® Fireplace

with Fire-Lite+ Application

and DM Chimney System

Installation, Operation, Maintenance and Owner's Manual

MAGNUM Models: 82060 & 82072

A PRODUCT OF EARTHCORE INDUSTRIES, LLC.

Important: This manual contains assembly rules, installation steps, guidelines, use and maintenance instructions for the MAGNUM 82060 & 82072 fireplaces and the DM chimney system, and Fire-Lite+ Application with the ECO-STEEL & ECOSTEEL+ Chimney System. This manual must become the property of and be reviewed by all current and future users of this product. It is the responsibility of the general contractor and the installer of this product to ensure that the instructions in this manual are followed exactly and that any allowed gas log appliance used in this product be installed in strict accordance with NFPA 58, NFPA 54/ANSI Z223.1 and the gas log manufacturer's explicit installation, sizing, and operation instructions. It is the responsibility of the general contractor to provide adequate clearances from all firebox surfaces as specified in this manual.

INSTALLER: Leave this manual with the fireplace

CONSUMER: Retain this manual for future reference

**Be Sure to Read Entire Manual Before Beginning Construction.
Contents of this manual may change without prior notification.**

DO NOT install the MAGNUM 60/72 Series Fireplace in a manufactured home or mobile home or recreational vehicle.

S

SBCCI NO. 9626
NYC-MEA 241-90-E
ICC Report NO. ESR-2316
LA RR NO. 25483
IBC 2006, IRC 2006, IMC 2006
Listing Services Report NO. F17-237



Issued: January 2025
Revision: 006.1
©2025 Earthcore Industries, LLC

THESE FIREPLACES ARE DESIGNED for USE with: Solid Wood Logs

APPROVED WITH DECORATIVE GAS APPLIANCE with PROPANE (LP) or NATURAL GAS (NG), ONLY

THIS MANUAL CAN ONLY BE REPRODUCED IN ITS ENTIRETY

Table of Contents

Table of Contents.....	2
General Information	3-4
Safety Instructions	5-6
PFS Listing Label	7
MAGNUM 60 (82060).....	8
Component List - MAGNUM 60 (82060)	9
MAGNUM 72 (82072).....	10
Component List - MAGNUM 72 (82072)	11
Required Clearance to Combustibles.....	12-13
Supporting Floor System.....	14
Fire-Lite+ Application - 60 & 72 Models Only	15-16
Rough Framing Dimensions	17
General Assembly Instructions	18
Assembly Instructions – MAGNUM 60	19-23
Assembly Instructions – MAGNUM 72	24-28
DM Chimney Components & General Information.....	29
DM Chimney Components: Weight & Height Requirements.....	30
DM Chimney Installation: Straight Run.....	30-32
DM Chimney Installation – Offset Run.....	32-34
DM Chimney Installation – Brick Ledge	35-38
DM Chimney Installation – Crown Caps.....	38
DM 54 Installation - Terminations.....	39
ECO-STEEL & ECO-STEEL + Metal Chimney Flue.....	40
Components List - ECO-STEEL Metal Chimney Flue.....	41
Components List - ECO-STEEL+ Metal Chimney Flue.....	42
Components List -ECO-STEEL/ ECO-STEEL+ Common Components.....	43
ECO-STEEL & ECO-STEEL + General Information	44
ECO-STEEL & ECO-STEEL+ Metal Chimney Installation	45-49
Guide for Mechanical Draft System.....	50
Access Modification - Combustion Air Kits, Gas & Electrical Line Feed	51
Firebrick Installation	52
Flush Wall Finish Detail.....	53
Clearance to Combustible Trim- 60 & 72 Models.....	54
Specialty Applications – Outdoor Installation	55
Specialty Applications – Reduced Height Fireplace Opening	56
Specialty Applications– Recessed Fire-Lite Application	56-57
Seismic Requirements (Slab on Grade)	58
Summary	59-61
Notes	62
Registration Card	63
Warranty & Disclaimer	64

General Information

The MAGNUM 60" & 72" Series fireplace and DM chimney system are a prefabricated, refractory, modular fireplace and chimney system designed for field assembly. The system consists of interlocking precast parts which are adhered (versus glued) together with a masonry adhesive.

The parts of the MAGNUM 60" & 72" Series fireplace and DM chimney system are precast using a proprietary mixture of volcanic pumice aggregate and cement. It includes all the parts necessary for assembly of a complete firebox, smoke dome, and chimney system.

Each MAGNUM 60" & 72" Series precast fireplace component is designed for a specific part of the fireplace such that only one means for assembly is possible.

The firebox and smoke dome are designed to be fitted with a traditional cast iron, poker-style throat damper, however, metal flue pipe, electronic, or chimney top dampers are options.

The MAGNUM 60" & 72" Series fireplace requires a standard refractory firebrick liner to be applied to the interior of the firebox. The 60" & 72" models require a minimum 1-1/8" thick firebrick for the Floor and Backwall (Fire-Lite + application: minimum 2-1/2") and 4" thick firebrick on the sidewalls.

All units have a (38") rough opening height before firebrick is installed. The only parts which differ among the available sizes are width related pieces. All units use the same sidewall pieces.

Two (2) flues are necessary on the 60" & 72" models without an mechanically assisted drafting system. It is acceptable to use mechanical assist draft systems if the venting companies perform the engineering calculations and make the necessary recommendations for fan size and flue vent diameter following the guidelines of NFPA 211/2006. Installation of such systems must also follow the mechanical drafting company's explicit installation and operation instructions.

The DM chimney system is a dual module refractory chimney system. The basic chimney consists of an outer casing block and an inner liner. The DM chimney components are field assembled using Earthcore Adhesive to glue the components together. The DM chimney system also includes an offset chimney block component, used to create offsets to the vertical run of the chimney. A brick ledge component that is designed to support chimney top brick veneer finishes is available. Prefabricated masonry chimney termination caps are also available.

The MAGNUM 60 & 72 Series fireplace and DM chimney components will be described and illustrated in the following pages. Close attention should be paid to each component group's specifications and installation requirements as described in this manual.

Recommended minimum overall height for the Isokern fireplace, DM, ECO-STEEL & ECO-STEEL + chimney system for an indoor application is 18'-0" when the chimney is straight and 21'-0" when a chimney is offset.

Maximum DM chimney height without any additional support needed is 22'-0". If additional structural support is provided, this height may be increased to a maximum of 82'. Consult local structural engineer for proper job specific support structure design, sizing, and load bearing specifications for the MAGNUM Models 60 & 72.

IMPORTANT: "Smoke free" operation is not warranted nor is the manufacturer responsible for inadequate system draft caused by mechanical systems, general construction conditions, inadequate chimney heights, adverse wind conditions or any unusual environmental conditions or factors beyond the manufacturer's control.

Intended Product Use Statement: The MAGNUM 60 & 72 Series fireplace and DM chimney systems are intended to burn solid wood fuel, propane, or natural gas.

NOTE: Installation of a gas pipe must comply with the Standard for Decorative Gas Appliances for Installation in Vented Fireplaces, ANSI Z21.60.

This fireplace is intended for use as a supplemental heat source only and is not intended for heavy use as a primary heating system. Over-firing, abusive burning or mistreatment will void any claims (e.g., burning construction debris or other highly flammable material; tossing, kicking, or otherwise forcing logs into the firebox).

The MAGNUM 60 & 72 Series fireplaces and DM chimney systems are conventional indoor or outdoor fireplaces designed to appear like traditional masonry fireplaces. The MAGNUM 60 & 72 Series fireplace and DM chimney system units are intended for installation in residential homes and other buildings of conventional construction.

NOTE: The local authority having code jurisdiction should be consulted before installation to determine the need to obtain a permit.

General Information

Important areas of concern with the installation of MAGNUM 60" & 72" Series fireplaces are construction of proper load bearing foundation and concrete support slab; code required hearth extension substrates and supports; proper assembly of components; clearance to combustible materials; height of chimney; and techniques employed in applying finishing materials to the fireplace opening and hearth extension.

Each of these important topics will be covered in detail throughout this manual. Installation personnel must give special attention to each topic as the installation progresses.

All work performed on, near, and adjoining the fireplace and chimney installation must meet or exceed the specifications and requirements in this manual and the prevailing local building code.

Subsequent renovations, additions of cabinets and storage spaces in the enclosure surrounding the fireplace are also limited to the specifications in this manual and to the prevailing local building code.

IMPORTANT: Isokern is not responsible for other construction work around the fireplace unit.

- We recommend two (2) 4" outside air kits for the Magnum 60 & 72 Models.
- The 60" and 72" MAGNUM Series fireplace is tested and listed by PFS - Report No. F17-237 and tested to UL-127.
- DM chimney system is tested and listed by PFS - Report No.F17-237,UL 127, and UL 103HT.

MAGNUM 60 &72 Series fireplace systems are also designed for installation in accordance with the National Fire Protection Association Standard for chimneys, fireplaces, vents and Solid Fuel-Burning Appliances (NFPA 211).

SEISMIC CODE:

If you are installing the MAGNUM Series Fireplace in a location where there is seismic code, follow the instructions for installation on page 56.

Four No. 4 ASTM A615 Grade 40 minimum, vertical reinforcing bars, 2 on the inside of each sidewall cavity running from approximately 4-1/2 inches into the concrete slab (for anchorage) to the top of the side wall cavity and fill with 2000psi minimum concrete or grout. Also see page 56 for more information.

For seismic anchorage design and instructions of the flush hearth application, please contact the Technical Department at 1-800-642-2920.

IMPORTANT: The top plate of the firebox is not meant to be used as a structural support, except as shown in the offset section of this manual. Please consult structural engineer for structural support of any veneer bearing weight on the Isokern top plate.

NOTE: Do not scale drawings. Illustrations in this manual are not to scale and are intended to show "typical" installations.

Nominal dimensions are given for design and framing reference only since actual installations may vary due to job specific design preferences. Always maintain the stated minimum clearances to combustible materials. Do not violate any specific installation requirements.

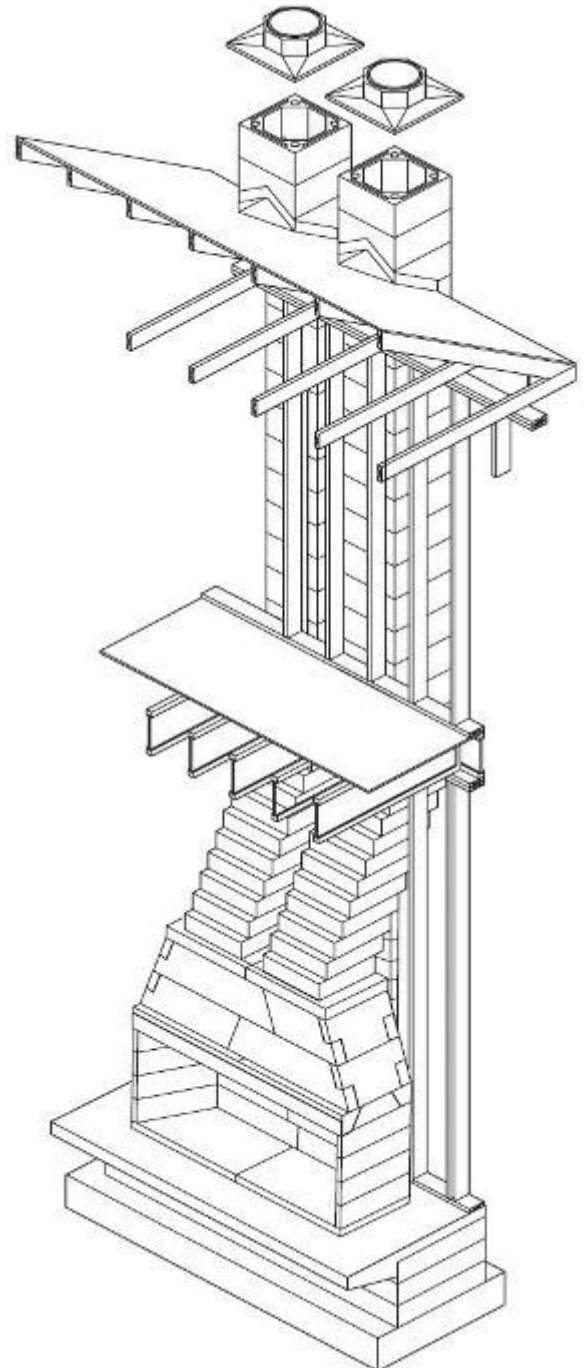

Safety Instructions

WARNING: This product contains or generates chemicals known to the state of California to cause cancer or birth defects or other reproductive harm.

IMPORTANT: Read this owner's manual carefully and completely before trying to assemble, operate or service this fireplace. Improper use of this fireplace can cause serious injury or death from fire, burns, explosions and carbon monoxide poisoning.

DANGER: CARBON MONOXIDE POISONING MAY LEAD TO DEATH!

If gas application is used with MAGNUM 60 & 72 Series fireplace; Propane (LP) gas and natural gas (NG) are both colorless and odorless gases. An odor-making agent is added to each of these gases to help you detect a gas leak. However, the odor added to these gases can fade and gas may be present even though no odor exists.

Carbon Monoxide Poisoning: Early signs of carbon monoxide poisoning resemble flu symptoms, including headaches, dizziness, or nausea. If you have these signs the fireplace may not have been installed properly, get fresh air at once! Have the fireplace inspected and serviced by a qualified service person or your gas supplier. Some people are more affected by carbon monoxide than others. These include pregnant women, people with heart or lung diseases or anemia, people at high altitude or under the influence of alcohol. Earthcore Industries strongly recommends the use of a carbon monoxide detector/alarm device wherever gas fired appliances are in use.

All parties either involved in or associated with the installation, service and use of this fireplace must read this entire manual. Keep this manual for reference and as a guidebook to safe operation of this fireplace.

-
1. Always check local building codes governing fireplaces and fireplace installations. The MAGNUM 60- 72 Series Fireplace and DM chimney installation must comply with all local, regional, state and national codes and regulations.
 2. The MAGNUM 60 &72 Series fireplace and DM chimney systems are intended for use in any application where a traditional masonry type fireplace would apply. The chimney system must always vent vertically to the outside of the building.
 3. Creosote and soot formation and the need for removal: When wood is burned slowly, it produces tar and other organic vapors which combine with expelled moisture to form creosote. The creosote vapors condense in the relatively cool chimney flue of a slow burning fire. As a result, creosote residue accumulates on the flue lining. When ignited this creosote makes an extremely hot fire.

Due to creosote and soot buildup it is necessary to inspect and clean the fireplace and chimney prior to use and periodically during the heating season. Cleaning of the fireplace and the chimney system should be done annually at a minimum. In colder climates, chimney cleaning may need to be done periodically throughout the heating season.
 4. Before servicing, allow the fireplace to cool. Always shut off any electricity or gas to the fireplace while working on it.
 5. Use only solid fuel or decorative Gas appliance in this unit. Do not use artificial wax-based logs, chemical chimney cleaners or flame colorants in this fireplace.
 6. For propane (LP) use do not place propane supply tank(s) inside any structure. Locate propane supply tank(s) outdoors. To prevent performance problems, do not use propane fuel tank of less than 100 lbs. capacity.
 7. Never use gasoline, kerosene, gasoline-type lantern fuel, charcoal lighter fluid, or similar liquids to start or "freshen up" a fire in this fireplace. Keep all flammable liquids at a safe distance from the fireplace.
 8. Always keep the flue damper open when heat is present in the fireplace.
 9. Do not use a fireplace insert or any other product not specified for use with the MAGNUM 60 &72 Series fireplace and DM chimney systems unless written authorization is given by Earthcore Industries, LLC. Failure to heed this warning may cause a fire hazard and will void the warranty.
 10. This fireplace is not intended to heat an entire home or to be used as a primary heat source. It is designed to ensure homeowner comfort by providing supplemental heat to the room.

Safety Instructions

11. Always ensure that an adequate supply of replacement combustion air from the outside of the house is accessible to the fire to support normal combustion. Fireplaces consume large volumes of air during the normal firing process.

In the event the home is tightly sealed and has modern energy efficient features, the combustion air supply kits may not provide all the air required to support combustion and the proper flow of combustion gases up the chimney.

The manufacturer is not responsible for any smoking or related problems that may result from the lack of adequate air supply flowing into the house. It is the responsibility of the builder/contractor to ensure that adequate air supply has been provided for the fireplace.

12. When in doubt about a component's usability - has visible or suspected physical damage - consult your Isokern distributor or authorized Isokern representative for advice.
13. Modification to MAGNUM 60 & 72 components not mentioned in this manual may void claims, listings and approvals and could result in an unsafe and potentially dangerous installation.

Alterations to the MAGNUM 60 & 72 firebox are allowed with prior written approval and instructions from Earthcore Industries, LLC. The installer indemnifies the manufacturer of all claims and under no circumstances will the manufacturer be liable for consequential, incidental, indirect, punitive or other damages of any kind or nature, whether foreseeable or not, based on any claim by any party as to the modifications of the Isokern fireplaces.

14. Keep all insulation, vapor barriers, "house wrap" paper and other insulating type membranes and products, including fiberglass, cellulose and other insulation, (anything that carries an "R" rating) a minimum of three inches (3") away from all firebox and chimney surfaces.

EXCEPTION: If insulation is used in walls surrounding the fireplace, insulation may be installed behind sheathing of gypsum board, plywood, particle board or other material on the side facing the Isokern. The facing material cannot be within 1-1/2" to the sidewalls and backwalls of the fireplace.

WARNING: Do not pack required air spaces with insulation or other materials.

15. Never leave children unattended when there is a fire burning in the fireplace.
16. Burning some fuels can be hazardous due to the possibility of producing carbon monoxide, a colorless, odorless gas. Early signs of carbon monoxide poisoning resemble flu symptoms, including headaches, dizziness, or nausea. Overexposure to carbon monoxide can lead to illness and death. It is strongly recommended to install smoke and carbon monoxide alarm / detector devices wherever fireplaces are installed.
17. Young children should be carefully supervised when they are in the same room as the appliance. Toddlers, young children, and others may be susceptible to accidental contact burns. A physical barrier is recommended if there are at-risk individuals in the house. To restrict access to the fireplace, install an adjustable safety gate to keep toddlers, young children, and other at-risk individuals out of the room and away from hot surfaces.
18. Clothing or flammable material should not be placed on or near the fireplace.
19. Due to high temperatures, the fireplace should be located out of traffic and away from furniture and draperies.
20. **Do not nail or screw into the Isokern fireplace, which includes firebox, smoke dome and DM Chimney components unless attaching the anchor plate for the metal flue system. This may alter the integrity of the fireplace and cause a house fire. This will VOID the warranty of the fireplace.**
21. Never spray or apply any type of sealer, insulation, or other materials to the fireplace.

PFS Listing Label



PFS
C US
PFS REPORT NO: F17-237

MODULAR REFRACTORY FIREPLACE

MAGNUM: 82060 82072

CERTIFIED TO: UL 127, ULC S610

SERIAL NO: N000001

CLEARANCE TO COMBUSTIBLES:

SMOKE DOME FRONT AND ISOKERN CHIMNEY	= 0 in	
UNIT SIDES AND REAR	= 1.5 in	(38 mm)
COMBUSTIBLE SHEATHING ABOVE OPENING	= 24 in	(610 mm)
TOP SHEATHING OR TRIM TO OPENING SIDES	= 9 in	(229 mm)
MANTEL ABOVE OPENING	= 24 in	(610 mm)
OPENING TO SIDEWALL	= 48 in	(1219 mm)
HEARTH EXTENSION BEYOND FRONT	= 30 in	(762 mm)
HEARTH EXTENSION BEYOND SIDES	= 12 in	(305 mm)
COMBUSTIBLE FLOOR (MUST USE FIRE-LITE+ APPLICATION)	= 7.5 in	(191 mm)
INSULATION FROM FIREBOX	= 3 in	(76 mm)

ISOKERN
EARTHCORE INDUSTRIES

MADE IN USA
CHESAPEAKE, VA 23323

HEADQUARTERS
JACKSONVILLE, FL 32256

USE SOLID WOOD FUEL OR LISTED DECORATIVE GAS VENTED OR UNVENTED APPLIANCE. ALSO FOR USE WITH LISTED METAL CHIMNEY. FIRE-LITE+ APPLICATION TO USE ECO-STEEL OR ECO-STEEL+ CHIMNEY ONLY.

DO NOT USE A FIREPLACE INSERT OR OTHER PRODUCTS NOT SPECIFIED FOR USE WITH THIS PRODUCT. WARNING: THIS FIREPLACE HAS NOT BEEN TESTED FOR USE WITH GLASS DOORS. TO REDUCE THE RISK OF FIRE OR INJURY, DO NOT INSTALL GLASS DOORS. WHEN BURNING GAS IN THE FIREPLACE, ADJUST THE DAMPER TO THE FULLY OPEN POSITION. DO NOT OPERATE AN UNVENTED GAS LOG SET IN THIS FIREPLACE WITH THE CHIMNEY REMOVED.

SEE INSTALLATION AND OPERATING INSTRUCTIONS FOR THIS MODEL AND ICC # ESR-2316

CONTACT BUILDING OFFICIAL PRIOR TO INSTALLATION.

The latest revision of this manual may be obtained at the Earthcore website:

<https://www.earthcore.com/installation-manuals/>

OR

Scan this QR code



Isokern Fireplace and Chimney Systems are tested and listed to UL standards: UL 127, ULC S610, and UL 103HT. The listing label shown above outlines the listed clearances to combustibles and indicates that the units are suitable for use with solid fuel or listed gas appliances. Refer to the manufacturer’s installation manual for detailed description of clearances to combustibles and all other installation information.

A metal listing label similar to those shown above is affixed to each fireplace. Do not remove the listing label from the fireplace.

Prior to beginning installation, contact your local building official to determine the need to obtain a permit.

MAGNUM 60 (82060)

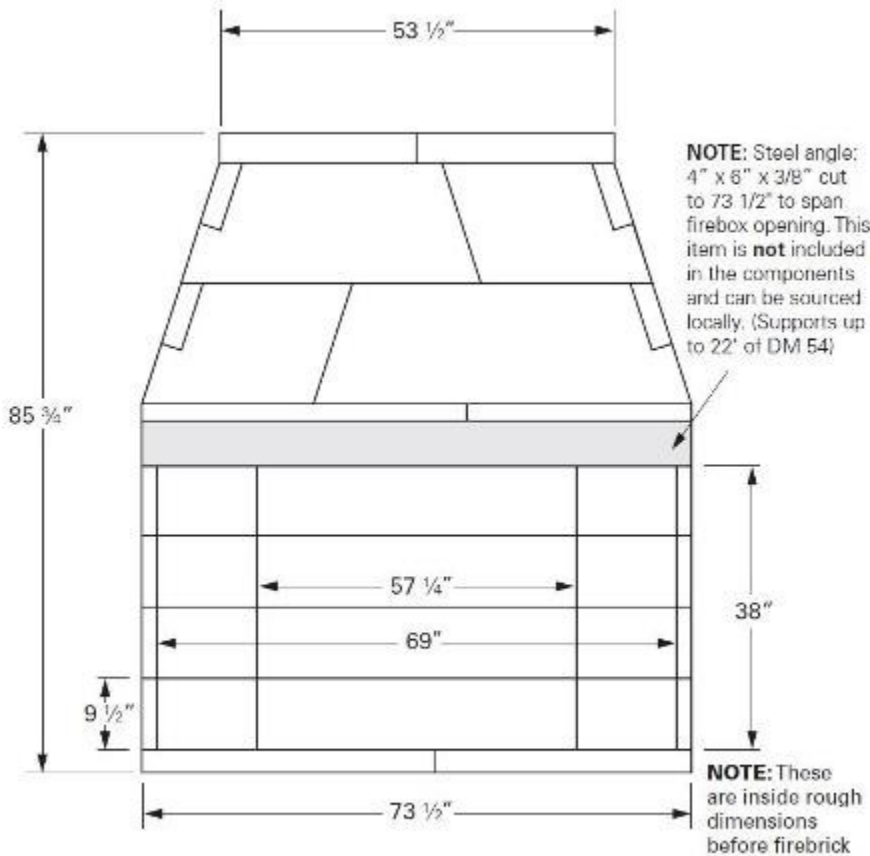

Front View

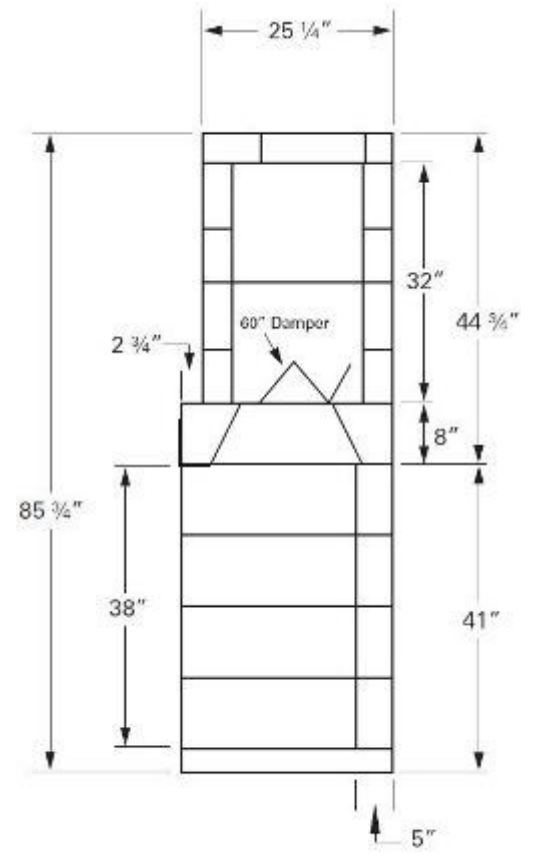

Side View

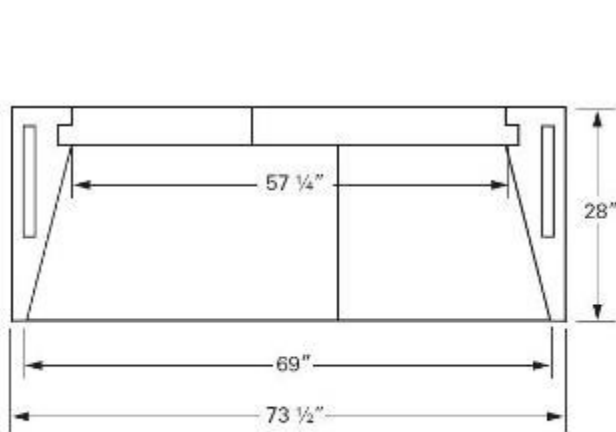



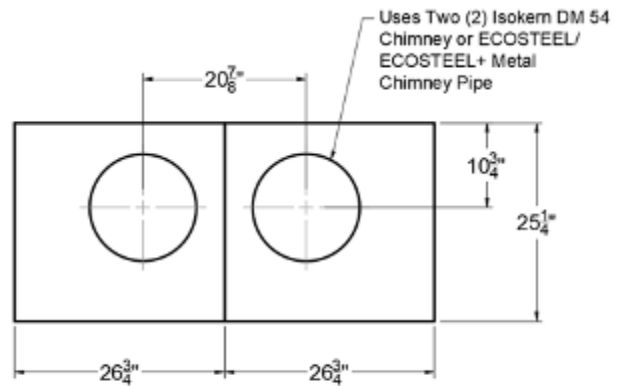

Plan View

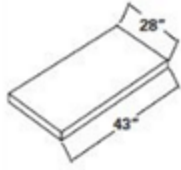
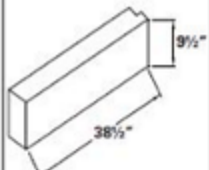
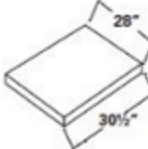
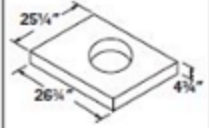

Top View

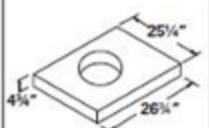
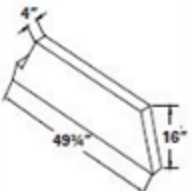
Component List - MAGNUM 60 (82060)

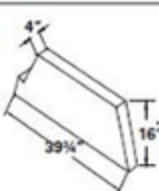
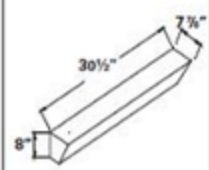
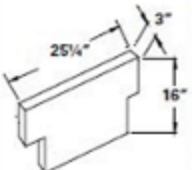
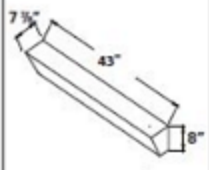
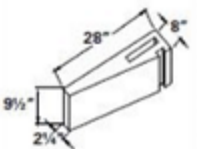
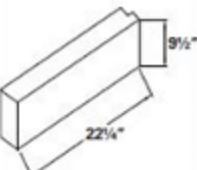
Component	Part#	Description	Component	Part#	Description
	M91	Isokern MAGNUM Base Plate		72	Isokern MAGNUM Backwall (Qty. 4)
	96	Isokern MAGNUM Base Plate		79L	Isokern MAGNUM Top Plate - Left
	15	Isokern MAGNUM Smoke Dome (Qty. 4)		79R	Isokern MAGNUM Top Plate - Right
	16	Isokern MAGNUM Smoke Dome (Qty. 2)		M94L & M94R	Isokern MAGNUM Damper End Left & Right
	17	Isokern MAGNUM Smoke Dome (Qty. 2)		74	Isokern MAGNUM Damper Beam (Qty. 2)
	34	Isokern MAGNUM Side Sloping (Qty. 4)		M68	Isokern Damper Beam (Qty. 2)
	M90	Isokern MAGNUM Sidewall (Qty. 8)			
	71	Isokern MAGNUM Backwall (Qty. 4)	NOTE: PRE-CUT parts are pre-packaged Magnum 60 only. These parts can't be ordered for extending Isokerns.		

MAGNUM 72 (82072)

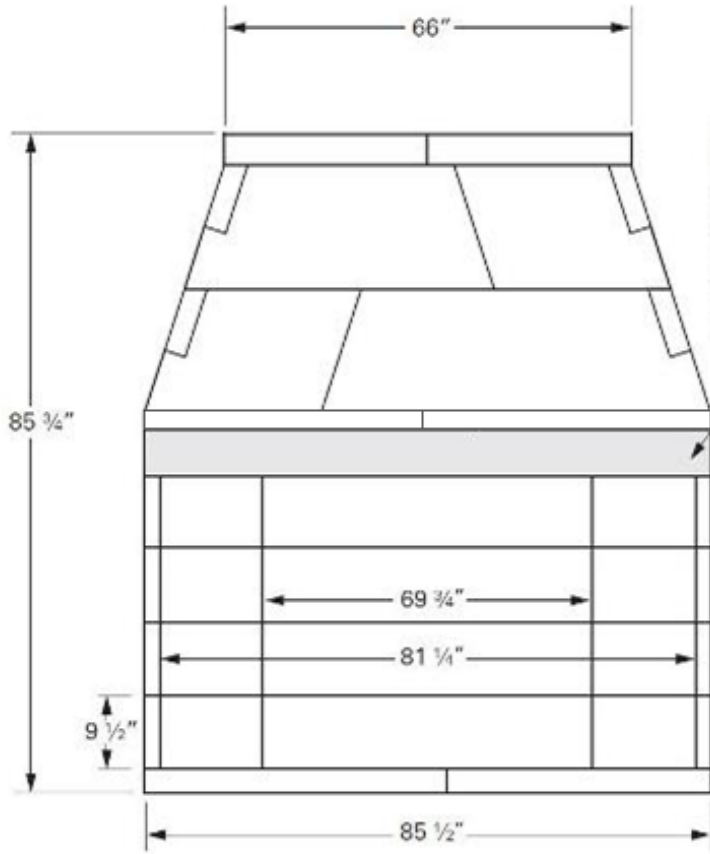

Front View

NOTE: Steel angle: 4" x 6" x 3/8" cut to 95 1/2" to span firebox opening. This item is **not** included in the components and can be sourced locally. (Supports up to 22' of DM 54)

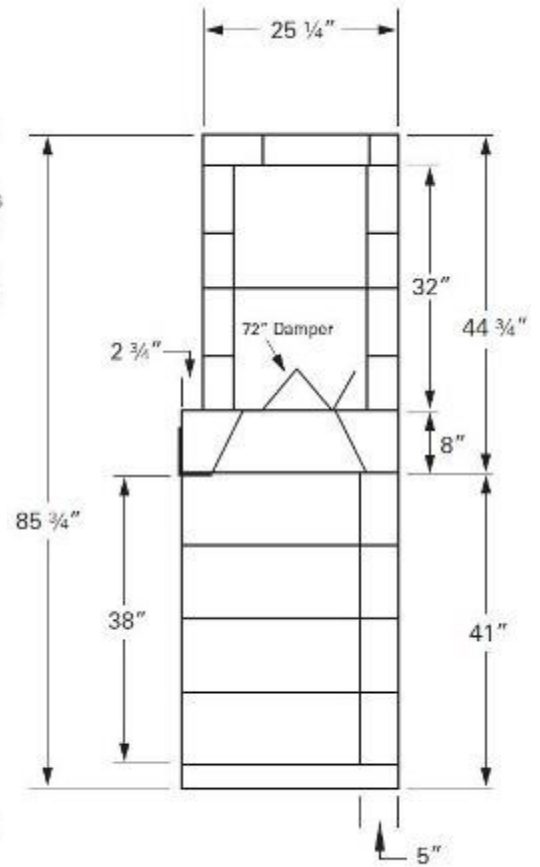

Side View

NOTE: These are inside rough dimensions before firebrick

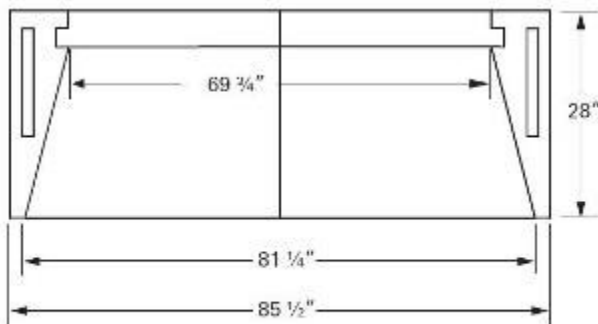



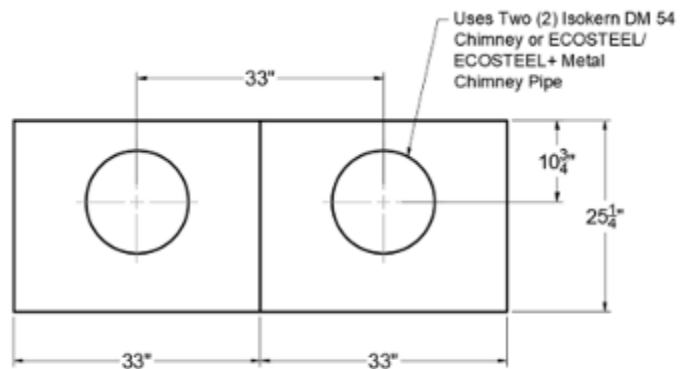

Plan View

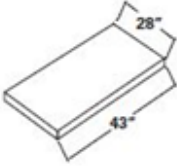
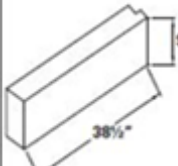
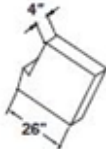
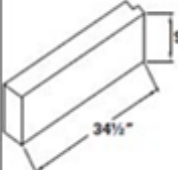
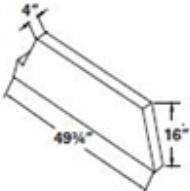

Top View

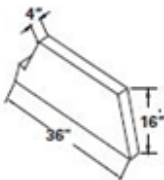
Component List - MAGNUM 72 (82072)

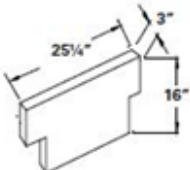
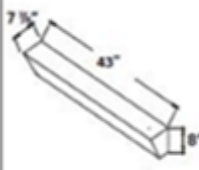
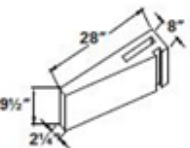
Component	Part#	Description	Component	Part#	Description
	M91	Isokern MAGNUM Base Plate (Qty. 2)		72	Isokern MAGNUM Backwall (Qty. 4)
	19	Isokern MAGNUM Smoke Dome (Qty. 2)		73	Isokern MAGNUM Backwall (Qty. 4)
	16	Isokern MAGNUM Smoke Dome (Qty. 4)		M77	Isokern MAGNUM Top Plate (Qty. 2)
	18	Isokern MAGNUM Smoke Dome (Qty. 2)		M94L & M94R	Isokern MAGNUM Damper End Left & Right
	34	Isokern MAGNUM Side Sloping (Qty. 4)		M68	Isokern Damper Beam (Qty. 4)
	M90	Isokern MAGNUM Sidewall (Qty. 8)			

NOTE: PRE-CUT parts are pre-packaged Magnum 72 only. These parts can't be ordered for extending Isokerns.

Required Clearance to Combustibles

The MAGNUM 60/72 Series fireplace and the DM chimney system is tested and listed for installation with “clearance to combustible framing” as follows:

- The MAGNUM 60/72 series firebox sidewalls and backwalls require 1-1/2” clearance. **(Figure 1)**
- The MAGNUM 60/72 series firebox’s smoke dome front wall requires 0” clearance. **(Figure 2)**
- DM54 Outer Casing component requires 0” clearance. **(Figure 2)**

NOTE: “Combustibles” are defined as “normal construction materials” and are considered to be: wood framing materials, particle board, mill board, plywood sub-flooring, plywood paneling and wood flooring.

The MAGNUM 60/72 Series fireplace is tested and listed for installation with “clearance to combustible sheathing” as follows:

- Combustible sheathing materials shall not be installed within 9” of the Sides of finished opening.
- Combustible sheathing materials shall not be installed within 24” (twenty-four inches) of the Top of finished opening

IMPORTANT: Drywall must be cut back from the firebox opening sides and above the top of the opening according to information above.

Keep all insulation, vapor barriers, “house wrap” paper and other insulating type membranes and products, including fiberglass, cellulose, and other insulation, (anything that carries an “R” rating) a minimum of three inches (3”) away from all firebox and chimney surfaces.

EXCEPTION: If insulation is used in walls surrounding the fireplace, insulation may be installed behind sheathing of gypsum board, plywood, particle board or other material on the side facing the Isokern. The facing material cannot be within 1-1/2” to the fireplace sidewalls.

IMPORTANT: The manufacturer is not responsible for installation and use practices that are beyond the scope of the product as defined in the product listing and in this installation manual.

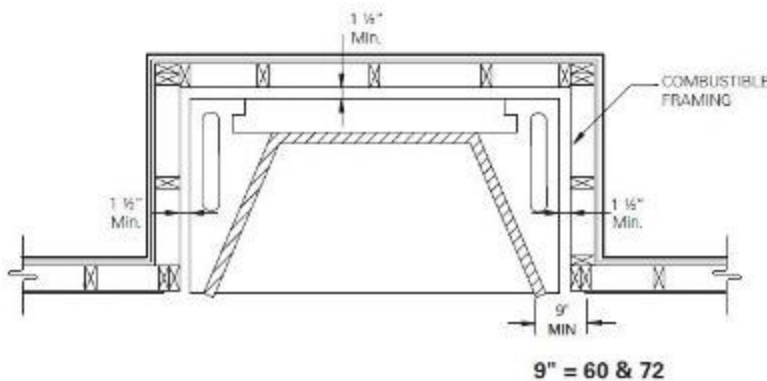

FIGURE 1

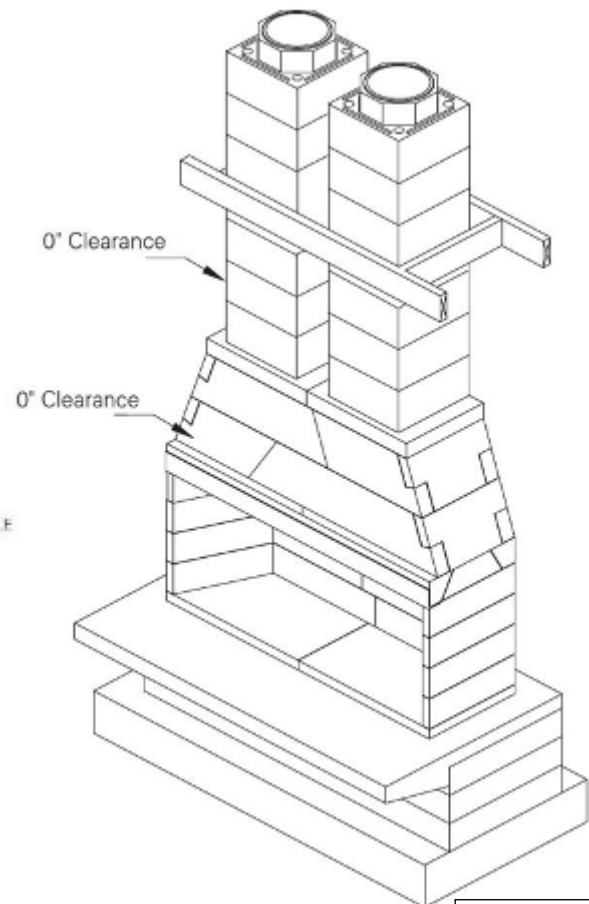

FIGURE 2

Required Clearance to Combustibles

Installation and use practices that are beyond the control of the manufacturer can result in situations where clearance requirements (as determined through testing and as stated by the manufacturer) are not maintained due to construction subsequent to the installation of the Isokern unit. It is the general contractor's responsibility to assure that listed clearances to combustible framing and to insulation are maintained throughout the construction of the project subsequent to the installation of the Isokern unit.

To avoid causing a fire resulting in damage to property, personal injury, or loss of life, do not pack or fill the required air spaces with insulation or other material. No material is allowed in these areas. **(Figures 1, 2, & 3)**

The MAGNUM 60/72 Series fireplace must sit upon a concrete support slab designed to bear the total installed weight of the fireplace and DM chimney system. These support slabs shall have no combustible underpinnings. **(Figure 3 & 4)** See pages 14 & 16 for more information on weight loads.

Concrete support slabs for MAGNUM 60/72 Series fireplaces must provide the non-combustible hearth extension substrate needed to support the code required non-combustible hearth extension finish materials. **(Figure 4).**

All MAGNUM 60/72 Series fireplaces shall have hearth extensions of approved non-combustible material such as brick, tile, or stone that is properly supported and with no combustible material against the underside thereof. This noncombustible hearth extension shall be set tight against the fireplace front and extend at least 30 inches out from the finished fireplace and at least 12" beyond the finished sides of the fireplace opening.

Wooden forms used during the construction of hearths and hearth extensions must be removed when the construction is complete.

If a raised fireplace floor and raised hearth extension are preferred, the raised underlying structure must be built of non-combustible material, be structurally designed to hold the weight of the fireplace and chimney system and must sit on non-combustible substrate.

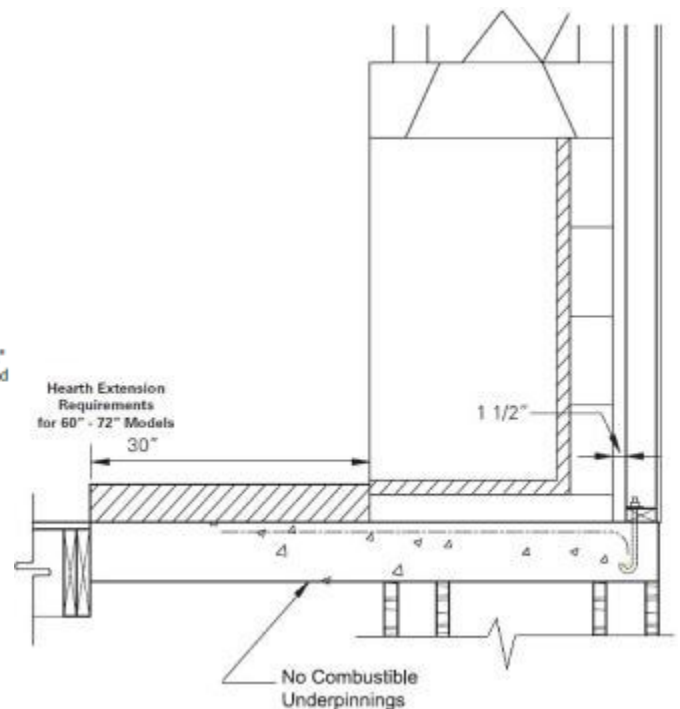
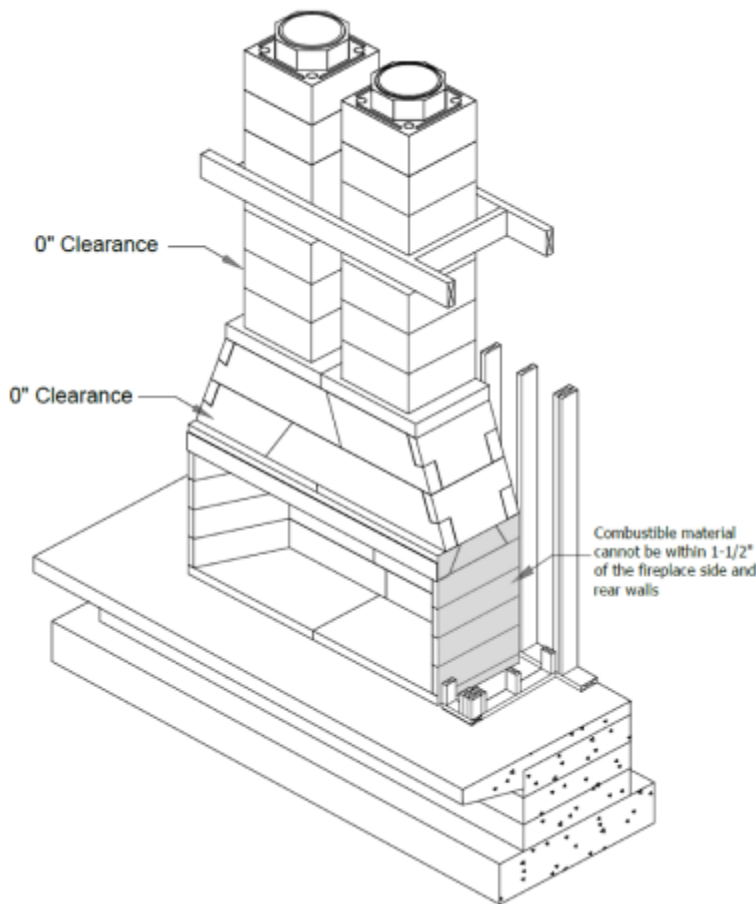

FIGURE 3

FIGURE 4

Supporting Floor System

The MAGNUM 60" & 72" Fireplaces are not rated for installation on a combustible floor system unless used in the Fire-Lite+ Application. (See Page 15). Fireplaces must be built upon a concrete support slab with no wood underpinnings. Proper reinforced concrete support slab for fireplace installations may include the following types:

1. Slab on grade: standard residential, minimum four inch (4") thick, 2500 psi concrete foundation on properly compacted fill. This type foundation can support Isokern DM chimney installations of up to thirty-feet (30')*overall height (brick-ledge installations not included). **(Figure 5)**

* This minimum installed height is derived from the maximum DM installation height without additional structural support; see pg. 3.

2. Slab-on-grade foundations, thickened and reinforced: These foundations are typically thickened for additional load carrying. **(Figure 6)**

3. Off-grade slab on foundation walls and footings: Projects with off-grade floor systems as well as upper-story installations require this type of support. When building off-grade support slabs the code required hearth extension substrate should be built as a continuation of the support slab for the fireplace unit. **(Figure 7)**. Supports for off-grade slabs must be concrete or steel and capable of supporting the slab, Isokern unit, and the chimney.

NOTE: For multi-floor and back-to-back installations proper weight computation on an individual basis is required. Consult a local structural engineer for load bearing requirements.

IMPORTANT: Foundations and footings must meet local code and be approved by the local building authority. For any foundation design and load requirements check with a local structural engineer. **It is the responsibility of the General Contractor to ensure adequate foundations.**

Fireplace weights* and "footprint" areas: The total fireplace weight and footprint for each model listed below includes the fireplace pumice components only:

- **MAGNUM 60:** 2394 lbs. @ 73.5" x 28" = 14.7 sq.ft.
- **MAGNUM 72:** 2721 lbs. @ 85.5" x 28" = 16.6 sq.ft.

"Footprint" areas listed above are base plate dimensions for each model and are exclusive of code required hearth extension areas

NOTE: Additional support slab area may be required at the side or back of the MAGNUM 60 & 72 unit to provide bearing for structural supports to a DM offset chimney sequence. (See page 32-34 for offset chimney support requirements).

FIGURE 5

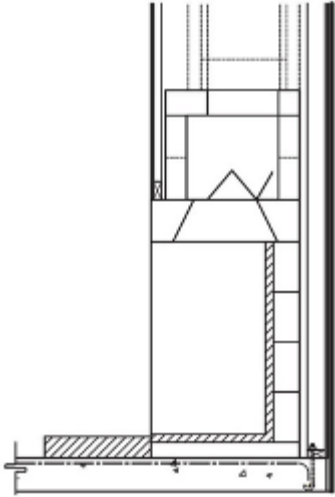

FIGURE 6

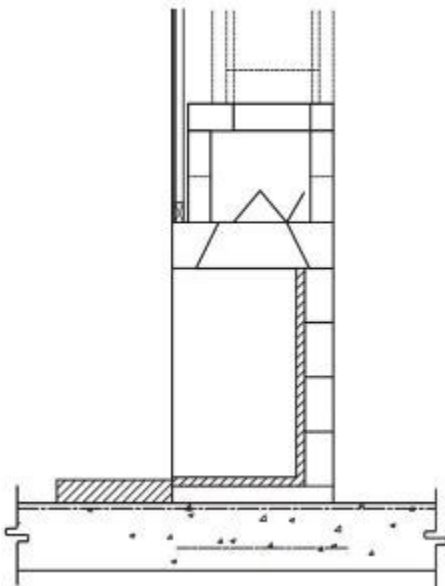
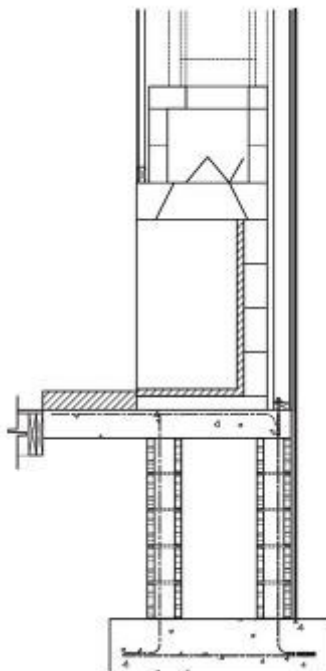

FIGURE 7



Fire-Lite+ Application - 60 & 72 Models Only

General Information

The Fire-Lite+ is an application of the Isokern MAGNUM 60" & 72" fireplaces designed, tested and listed with the ability to be installed on a combustible floor system. The Fire-Lite+ assembled unit must sit on a raised, non-combustible platform and when installed, creates a minimum 7-1/2" space between the Isokern fireplace's base plate bottom and the combustible floor. The design and installation require that the system use ECO-STEEL or ECO-STEEL+ metal chimney.

The following pages will refer to installation requirements specific to the Fire-Lite+ application using the Isokern Fire-Lite+ Kit. Use only the Fire-Lite+ Kit that is applicable with your fireplace (see chart below).

For recessed applications of the Fire-Lite+ kit, refer to the Specialty Application of this manual.

Intended Use Statement:

The Fire-Lite+ Application of the Isokern fireplace is designed to sit on a combustible floor system and is intended to burn solid wood fuel, propane, or natural gas. The fireplace is intended for use as a supplemental heat source only and is not intended for heavy use as a primary heating system.

The 60" & 72" Fire-Lite+ has been tested and listed by PFS (Report Nos. F17-237). These units are intended for installation in residential homes, and other buildings of conventional construction.

Fire-Lite+ Application of the Isokern fireplace are also designed for installation in accordance with the National Fire Protection Association Standard for chimneys, fireplaces, vents, and Solid Fuel-Burning Appliances (NFPA 211).

Clearance to Combustibles:

The Fire-Lite+ is tested and listed for installation with "clearance to combustibles" as follows:

1. 7-1/2" clearance to the combustible floor.
2. 0" clearance at the Isokern smoke dome front wall.
3. 1-1/2" clearance at the Isokern firebox back walls and side walls.
4. 3" Clearance to unshielded insulation.
5. 2" minimum air space to combustibles at all ECO-STEEL or ECO-STEEL+ metal chimney.

IMPORTANT: "Combustibles" are defined as "normal construction materials" and are considered to be: wood framing materials, particle board, mill board, plywood sub-flooring, plywood paneling and wood flooring. Sheathing materials, such as plywood, particle board and drywall may cover the smoke dome front at zero inch (0") clearance.

EXCEPTION: If insulation is used in walls surrounding the fireplace, insulation may be installed behind sheathing of gypsum board, plywood, particle board or other material on the side facing the Isokern. This facing material shall not be within 1-1/2" of the Isokern side or backwalls (**Figure 8**).

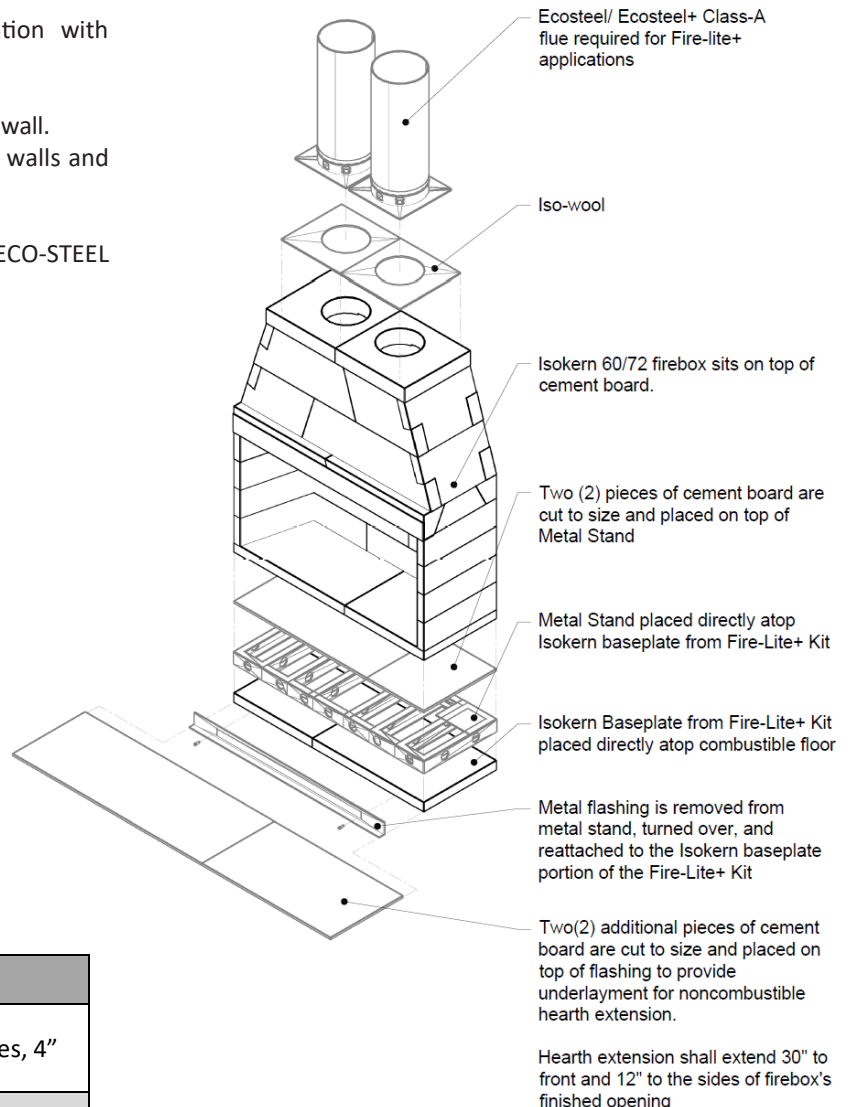

Part #	Description
FLK-60	Magnum 60 Fire-Lite + Kit. (Base Plates, 4"
FLK-72	Magnum 72 Fire-Lite + Kit. (Base Plates, 4"

FIGURE 8

Fire-Lite+ Application - 60 & 72 Models Only

NOTE: Floor framing for a Fire-Lite+ installation will need to be designed and built to accept substantial dead loads spread over a relatively small floor area. The following weights and sizes can be used to calculate Fire-Lite+ loading. Consult with local structural engineer for proper sizing of structural floor frame members for specific installations.

Load Calculations:

Total dead load amounts include (but are not necessarily limited to the following items and their corresponding weight estimates listed below:

MAGNUM 60 & 72 Series fireplace weights and “footprint” areas: The total fireplace weight for each model listed below includes pumice parts only:

MAGNUM 60": 2652 lbs. @ 73.5"x 28" = 14.29 sq.ft.

MAGNUM 72": 2952 lbs. @ 85.5"x 28" = 16.63 sq. ft.

NOTE: Weight totals listed above are exclusive of any firebrick, accessories, or ECOSTEEL/ ECOSTEEL + chimney components. DM chimney is not allowed on Fire-lite+ applications.

NOTE: “Footprint” areas listed above are base plate dimensions for each model and are exclusive of code required hearth extension areas.

Fire-Lite+ Application of the 60" & 72" fireplace results in the finished fire brick floor of the firebox being at least 13" above the combustible floor system. **(Figure 8 and 9)**

The noncombustible raised platform must be set with a minimum 1-1/2" clearance to the wall to the sides and directly behind the Fire-Lite+ assembly.

Raised 60 & 72 Platform:

The 60" & 72" Fire-Lite+ Kit consists of and should be installed in this order: 3" Fire-Lite+ Isokern base plate placed directly on combustible floor; 4" Fire-Lite+ metal stand; 1/2" cement board cut to span the width of the metal stand (requires 2 pieces); then Magnum fireplace base plate. **(Figure 8 and 9)**

IMPORTANT: Metal safety strip – a metal angle iron is attached to the Fire-Lite+ metal stand when shipped. This angle is to be removed before installation, turned over and re-attached to the 3" Fire-Lite+ Isokern base plate with 6 screws provided. This creates a metal safety strip and can be adjusted to ensure your Fire-Lite+ metal stand, set on top of the Fire-Lite+ Isokern base plate will be level. The safety strip must extend out from the front of the Fire-Lite+ Isokern base plate at least 2".

The 2 additional pieces of cement board provided shall be placed on top of flashing to provide underlayment for non-combustible hearth extension.

Firebrick Installation:

Magnum 60" & 72" installed with the Fire-Lite+ application must use 4" firebrick on this sidewalls. This can be accomplished either by turning “full-size” (9" x 4-1/2" x 2-1/2") firebricks to use the 4-1/2" face to accomplish the depth, or by combining a layer of “split-size” (9" x 4-1/2" x 1-1/4") + full size (9" x 4-1/2" x 2-1/2") firebricks. In addition, full size (9" x 4-1/2" x 2-1/2") firebricks must be used on the backwall and floor.

NOTE: For seismic anchorage design and instructions of the flush hearth application, please contact the Technical Department at 1-800-642-2920.

IMPORTANT: The 60" & 72" Fire-Lite+ Application is designed, tested, and approved for installation at a minimum of 7-1/2" above combustible floor.

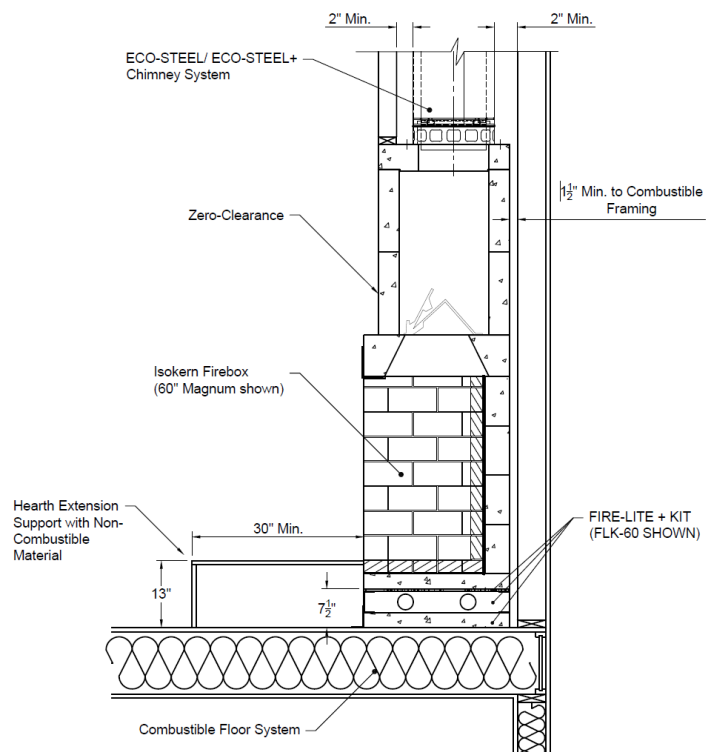

FIGURE 9

Rough Framing Dimensions

Typical Installation Framing Dimensions:

MODEL	Width - A	Height - B	Depth - C
82060	76 1/2"	87 1/2"	29 1/2"
82072	89"	87 1/2"	29 1/2"

Notes:

1. "B" includes the 3" thick base plate.
2. "Raised hearth" requires additional rough opening height at "B" equal to the height of the raised hearth detail.
3. Rough framing dimension for width "A" allows for the required 1-1/2" clearance at the sides of the Fireplace.
4. Rough framing dimension for Height "B" will need to be increased by 7-1/2" if the Fire-lite+ application is utilized.
5. Rough framing dimension for depth "C" allows for the required 1-1/2" clearance at the back of the fireplace. Note that this 29-1/2" is typically used on interior walls that do not have insulation present.

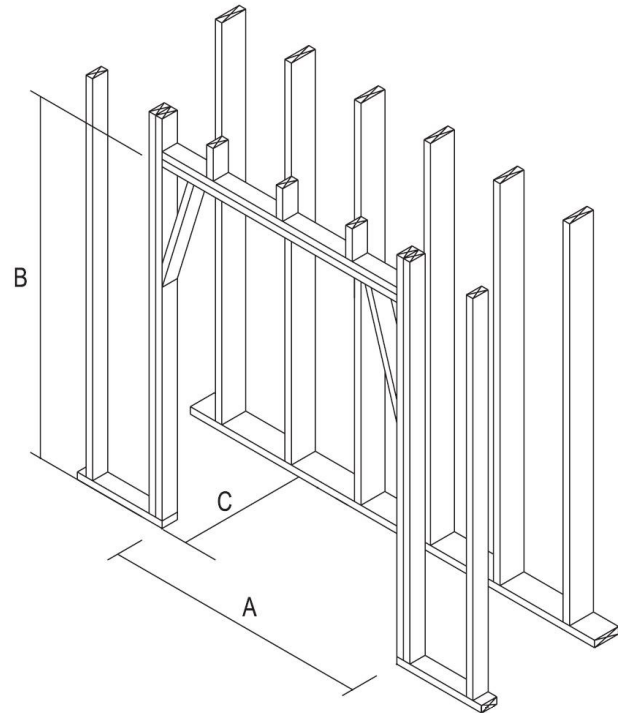

FIGURE 10

IMPORTANT: Unless the insulation on an exterior wall is installed behind plywood sheathing, a depth of 31" is often used to account for the required 3" clearance to insulation. Even with this increased distance, the installer should be aware that spray foam insulation may expand past the face of the stud wall and will require trimming prior to firebox installation to maintain the required 3" clearance. It is important that any insulation that is not installed behind sheathing shall be installed in such a manner that it cannot fall on the firebox and encroach on this clearance. (Figure 10)

Corner Installation Framing Dimensions

The following chart of dimensions detail the positioning of a MAGNUM 60 & 72 Series fireplace in a corner. It also details the positioning of DM chimney where it must turn 45° degrees if alignment is needed to overhead framing. (Figure 11)

MODEL	A	B	C	D
82060	76-1/2"	50-1/2"	61-1/2"	111"
82072	89"	56-1/2"	70-1/2"	119-1/2"

To turn flue 45°, first set starting inner liner onto the top plate of the fireplace.

Next, set a DM outer casing onto the inner liner so that the outer casing is at 45° to the firebox and square to the overhead framing system. Run the vertical DM chimney through the overhead framing.

Offset blocks can be used, if necessary, to align with overhead framing before running the vertical DM chimney outer casing and liner.

NOTE: Support the third offset down to footings and at each third offset block thereafter. Always support the last offset block in a sequence for full support of the DM chimney where it returns to vertical.

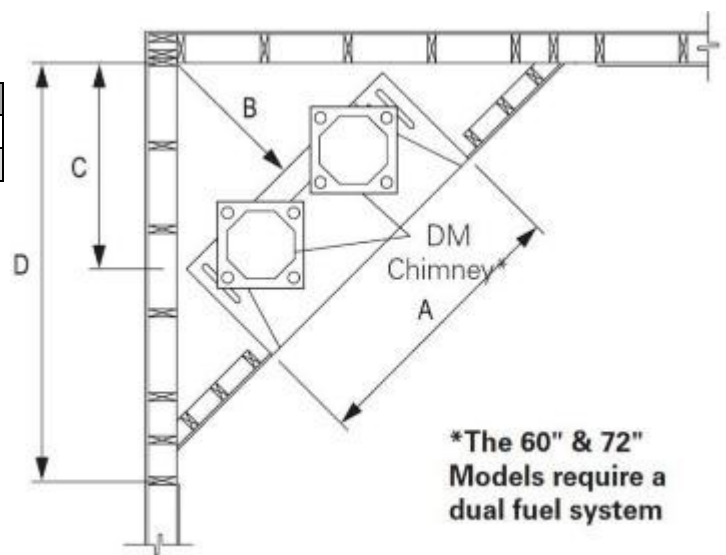

FIGURE 11

General Assembly Instructions

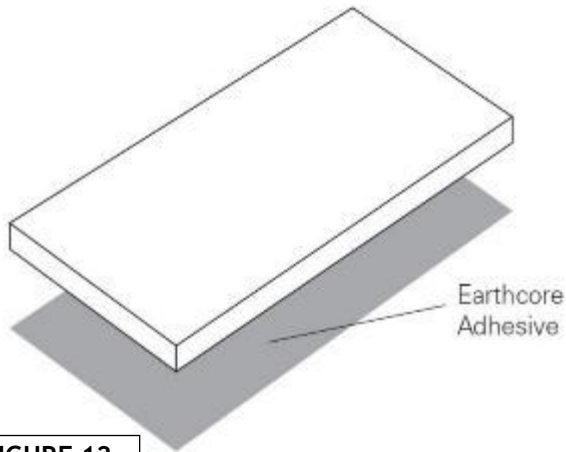

FIGURE 12

When beginning the assembly process, mix the Earthcore Adhesive with clean water to a smooth, workable texture (without lumps or dry pockets) of a “toothpaste” consistency. This mixture is suitable for application onto Isokern components by using a masonry grout bag supplied with the unit.

Attention should be paid that the Earthcore adhesive mixture is not too thin or runny, as this will not allow the Earthcore adhesive to reach its maximum bonding strength.

Mark out the position of the base plate on the supporting floor system. Apply a thin layer of Earthcore Adhesive to the area and set base plate in the mortar. **(Figure 12)**

Earthcore Adhesive is then squeezed from a grout bag onto the contact surfaces of the Isokern components as they are fitted together.

NOTE: It is important that a 1/2” bead of Earthcore adhesive is piped onto all the components’ contact surfaces, about 1/2” in from all edges. **(Figure 13)**

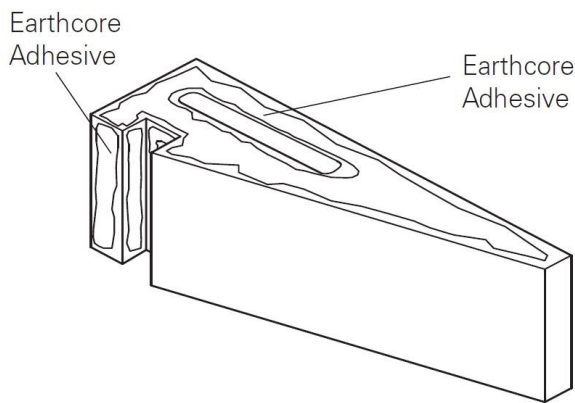

FIGURE 13

When setting the next component onto the Earthcore adhesive contact surface of the base plate, some Earthcore adhesive should squeeze out along the face of the entire joint as a sign of complete and proper sealing of the joint.

On broader contact surfaces it is advisable to apply several additional 1/2” beads of the Earthcore Adhesive to the area to assure proper sealing of the joint.

A properly adhered firebox and smoke dome assembly requires approximately 100 pounds (dry measure) of Earthcore Adhesive.

Leveling and Aligning Components:

Be sure to assemble all Isokern components level and flush with adjoining components.

Earthcore Adhesive is not intended to create a Earthcore adhesive joint of any thickness for leveling purposes. Therefore, leveling and alignment adjustments are made by the use of small plastic shims supplied with the unit. **(Figure 14)**

The shims can be inserted under a component to level and align it with adjacent Isokern components. Be sure to re-grout any and all gaps resulting from shim insertion to maintain components to full bearing.

Broken Components:

Components can be repaired by using Earthcore adhesive along the break line as the component is set into place. Components broken into multiple small pieces should be discarded and replaced.

IMPORTANT:

- Do not mix Earthcore Adhesive with anti-freeze agents.
- The maximum recommended Earthcore adhesive joint thickness at Isokern components is 1/4”.

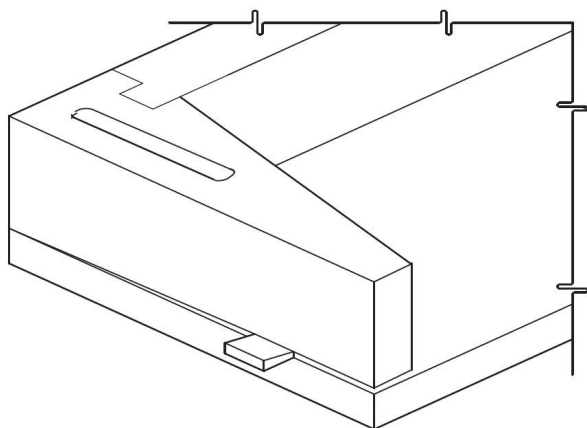

FIGURE 14

Assembly Instructions – MAGNUM 60

The following assembly instructions identify the parts by name, part number, and the placement of each part in the assembly process.

NOTE: At all component placement, be sure to apply Earthcore Adhesive to all contact surfaces. Check for complete sealing of each contact joint while assembly progresses.

1. Apply Earthcore adhesive to the joint between part #96 and part # M91 and set the base plates in a full bed of Earthcore Adhesive on a level support surface. See page 14 for supporting floor system. **(Figure 15)**. Do not set the base plate so that it is in span. The overall length of the base plate assembly should measure 73-1/2" wide and 28" deep.

Flush Hearth

If the design preference is for a "flush hearth" the base plate can be omitted from the assembly and the firebox walls built directly on a minimum 4" concrete support slab. The fire brick floor of the firebox is then set directly to the concrete support slab. This makes the fireplace finished fire brick floor approximately one and one-half inches (1-1/2") above the top of the concrete support slab.

Raised Hearth:

If the design preference is for a raised hearth (floor of the fireplace elevated above the room's floor), then the base plate can be set on a noncombustible platform that is built up to the desired raised hearth height on the concrete support slab.

When calculating raised hearth height be sure to allow for the three inch (3") thick base plate plus the one- and one-half inch (1-1/2") thick fire brick floor in addition to the height of the platform.

For all "raised hearth" construction where concrete blocks are used to create the raised platform, it is necessary to use the base plate. Be sure to Earthcore adhesive the concrete block platform together. CMU used for base plate support should be rated ASTM 90

Whether a flush hearth or a raised hearth is installed, all MAGNUM 60 & 72 Series fireplaces shall have hearth extensions of approved non-combustible material such as brick, tile, or stone that is properly supported and with no combustible material against the underside thereof. This noncombustible hearth extension shall be set tight against the fireplace front and extend at least 30 inches out from the finished fireplace and at least 12" beyond the finished sides of the fireplace opening.

2. Set the first course of the firebox side walls and back walls into place. **(Figure 16 & 17)**

NOTE: It may be convenient to dry set the first course of side walls and back walls into place on the Isokern base plate and then trace their position on the base plate with a pencil.

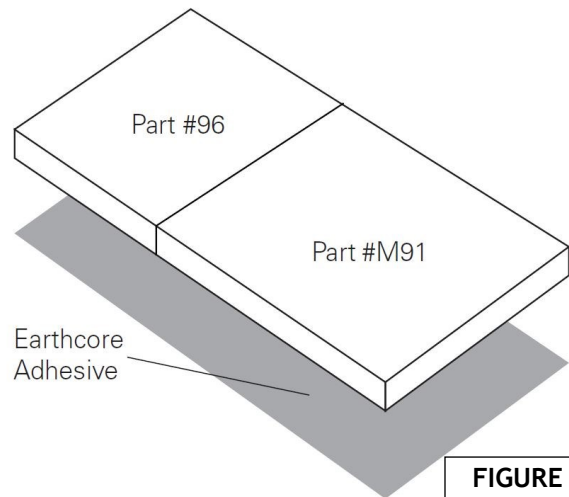

FIGURE 15

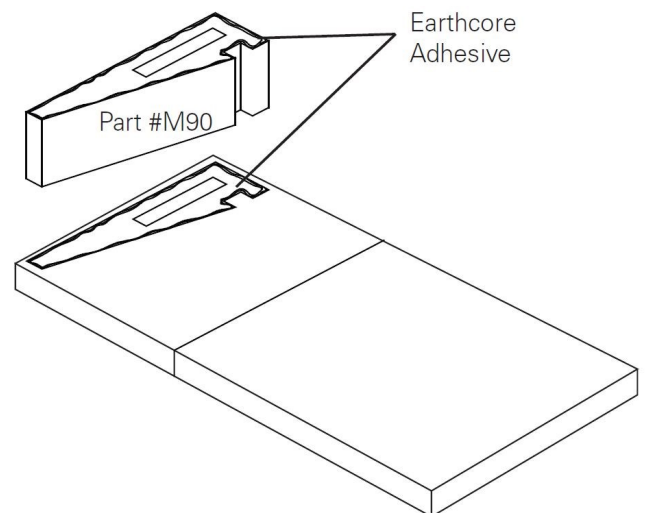

FIGURE 16

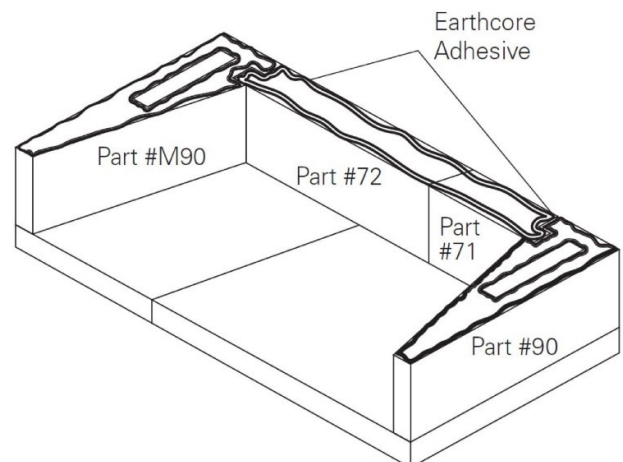

FIGURE 17

Assembly Instructions – MAGNUM 60

After outlining the dry set pieces, remove them and apply Earthcore adhesive to the areas traced on the base plate where the side walls and back wall are to sit. By doing this, the first layer of wall components can be set directly into Earthcore adhesive already applied to the proper areas on the base plate.

3. Continue assembly of the consecutive courses of the firebox side wall and back wall, making sure to stagger the backwall components so that the vertical joints do not align. Apply Earthcore adhesive to the top of each layer of wall components, then set the next course above into place. Be sure to Earthcore adhesive all vertical joints of the side walls, as well as the sidewall to back wall connection when setting each component to its mate. **(Figure 18)**

Look for some Earthcore adhesive to squeeze out along the joints of all contact surfaces as a sign that the joint is thoroughly sealed with the approved Earthcore adhesive.

4. When all of the firebox sidewall and backwall components are set, check the top surface of the firebox for level. If necessary, adjust the top surface of the box assembly for level by inserting a shim supplied with the unit between the lowest wall component and the top surface of the base plate.

Any gap created under the wall components during the shim leveling process must be filled with Earthcore Adhesive to fill bearing against the base plate.

5. Steel angle iron with measurements of 4" x 6" x 3/8" cut to 73½" long to span firebox opening will be needed to assemble the firebox. **This item is not included in the components and can be sourced locally.**

This steel angle sits on top of the uppermost side wall component with the four inch leg in the horizontal position. To avoid a thickness problem with the placement of the steel angle it is necessary to cut a notch in the top side wall component where the angle is to sit. This notch should be cut approximately 3/8" deep. The notch should start at the front face of the side wall component (at both the left- and right-hand walls) and run to a point 4" back toward the firebox. **(Figure 19)**

The steel angle sits in this notch. The six-inch leg of the steel angle is in the vertical position and is to be located in alignment with the front of the firebox. The ends of the steel angle should not protrude beyond the outer firebox side wall. Earthcore adhesive between the steel and the notch in the top of the side wall is not needed.

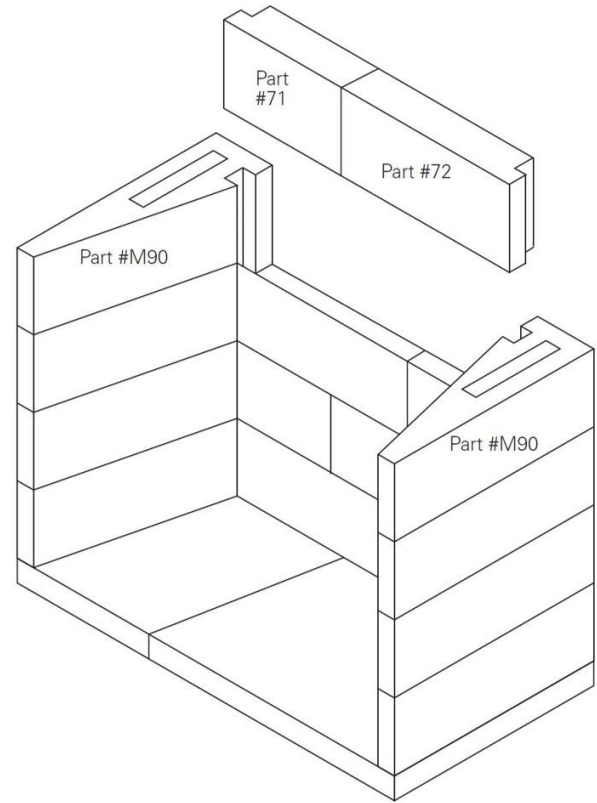

FIGURE 18

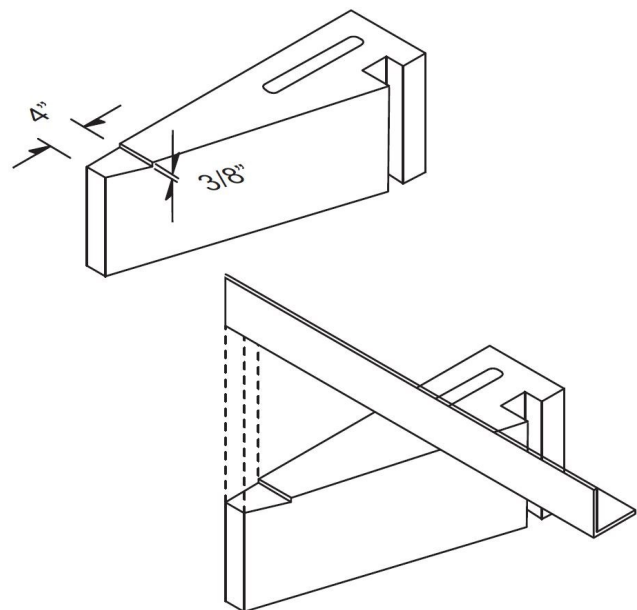

FIGURE 19

Assembly Instructions – MAGNUM 60

6. The fireplaces come with an eight-inch (8") thick damper beam assembly, a six (6) piece component group that is to be assembled on top of the firebox's sidewalls and backwall.

The damper beam assembly consists of four (4) long lintel pieces and two (2) short damper beam side pieces. The damper side pieces are designed to sit on the firebox side wall between the front lintel and the back lintel. Each of the damper side pieces is designed specifically for its own side of the unit. When properly set, each damper side piece fits flush with the outside face of the firebox sidewall so that its interior bottom edge aligns with the interior angle of the firebox side wall that it sits on. **(Figure 20)**

When part# 74 and part# 68 are put together they will be equal to the width of the fireplace. Properly placed, the lintel is to sit on top of the firebox back wall and flush with it; the other lintel sits flush with the front of the firebox, spanning the firebox opening. These components both sit on their narrow base so that their beveled face points down and into the firebox interior. **(Figure 21)**

Be sure to Earthcore adhesive all damper beam components to the top surfaces of the firebox. Earthcore adhesive the contact surfaces of each damper side component where it meets the front and back damper beam lintel components.

NOTE: The firebox and smoke dome are designed to be fitted with a traditional cast iron, poker-style throat damper that is placed on top of the damper beams during installation. In-line, bottom mount, or chimney top dampers are alternative options. The damper is not included with the firebox.

With the damper beams assembled together with Earthcore Adhesive, set the cast iron throat damper (unless another damper type is being used) on top of the damper beam and over the smoke chamber opening. The cast iron damper's operating plate should face toward the rear of the fireplace. The flange at all four sides of the cast iron damper should be supported by the damper beam's top surface.

Run a thin bead of Earthcore Adhesive around the four sides of the cast iron damper or tack the corners of the flange to avoid movement of the damper as it gets opened and closed.

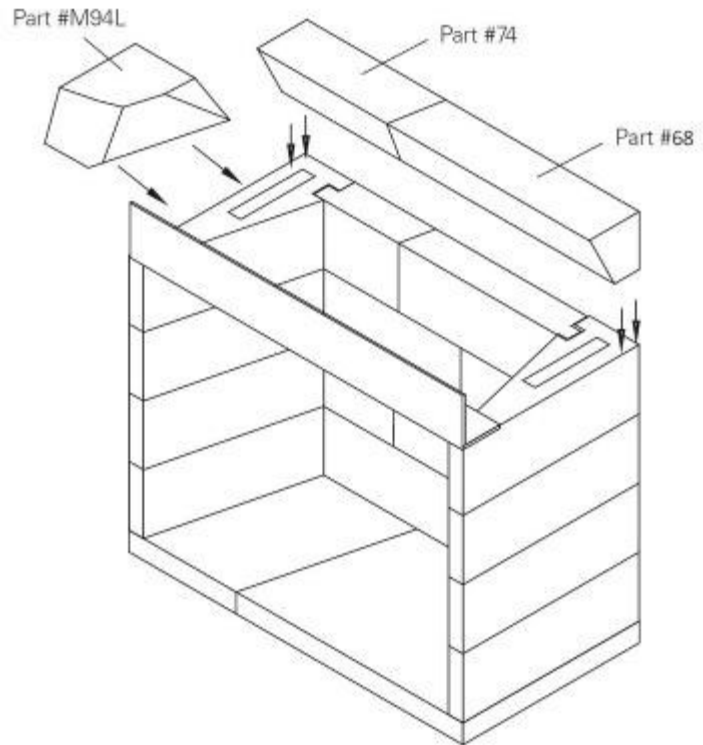

FIGURE 20

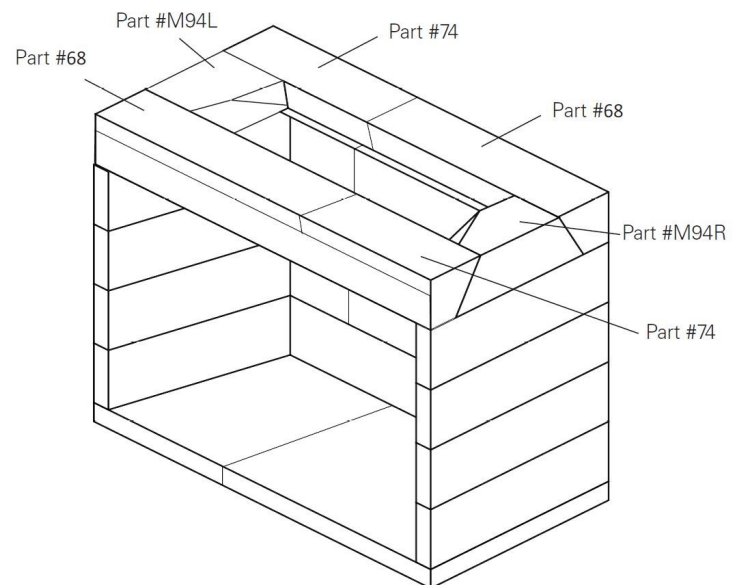

FIGURE 21

Assembly Instructions – MAGNUM 60

7. Set the rear smoke dome components across the damper beam in a bed of Earthcore adhesive and flush with the back face of the back damper beam lintel.

Set the front smoke dome components in Earthcore adhesive across the front damper beam and 2-3/4 inches back from the front of the front damper beam lintel. This placement should create a space of 17 inches (17") between the front and rear smoke dome components. **(Figure 22)**

8. Position the smoke dome's sloping sidewalls at each end of the smoke dome components. The sloping sidewalls fit in between the front and rear smoke dome components and also fit into the haunches at the ends of the front and rear smoke dome components. Earthcore adhesive all contact surfaces thoroughly. The smoke dome sloping sidewalls have a beveled bottom edge so that they will sit tight onto the flat top of the damper beam assembly. **(Figure 23)**

9. Set the second tier of rear smoke dome components across the top of the first tier of smoke dome components with Earthcore adhesive between the two tiers. Make sure both tiers are flush with one another.

Follow the same instructions of the second tier of rear smoke dome components for the second tier of front smoke dome components. This placement should create a space of 17 inches (17") between the front and rear smoke dome components. **(Figure 24)**

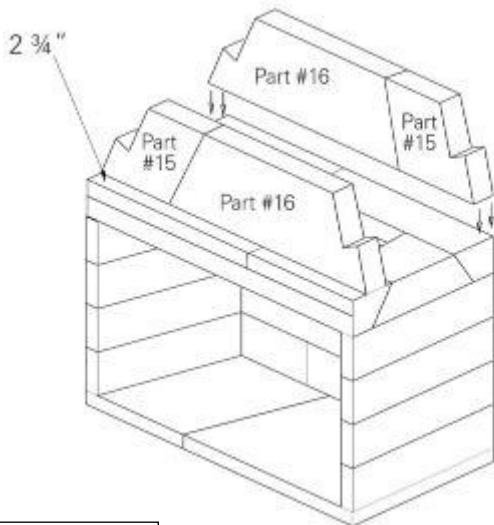

FIGURE 22

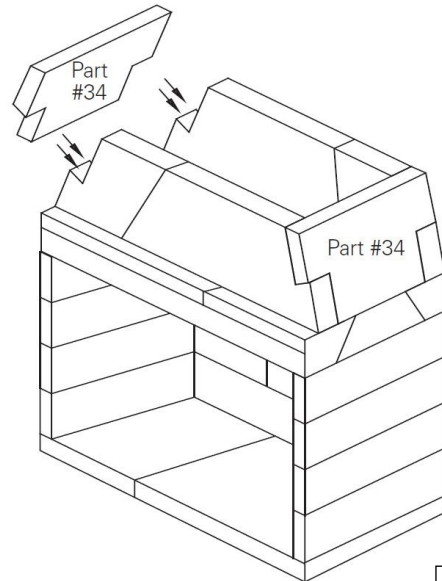

FIGURE 23

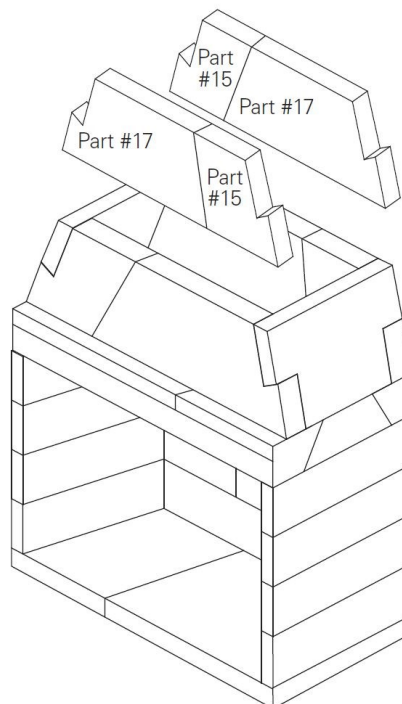

FIGURE 24

Assembly Instructions – MAGNUM 60

10. Position the second tier of smoke dome’s sloping sidewalls at each end of the smoke dome components. The sloping sidewalls fit in between the front and rear smoke dome components and also fit into the haunches at the ends of the front and rear smoke dome components. Earthcore adhesive all contact surfaces thoroughly. The smoke dome sloping sidewalls have a beveled bottom edge so that they will sit tight onto the flat top of the damper beam assembly. **(Figure 25)**
11. Apply Earthcore adhesive to the top of the smoke dome wall assembly and set the two top plates into position.

NOTE: One side of the top plate shows a thickened center. This side is the bottom face.

NOTE: The Magnum 60” fireplace comes with a left top plate (79L) and a right top plate (79R). When oriented properly on top of the firebox, the center of the flue outlet will be ten and three-fourths inches (10-¾”) from the back of the firebox and approximately ten and one-half inches (10-1/2”) from the center of the firebox. **(Figure 26)**

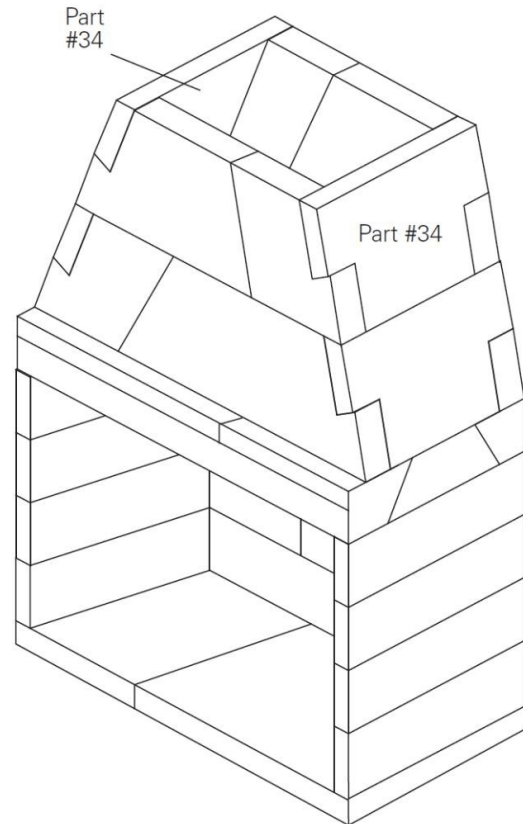

FIGURE 25

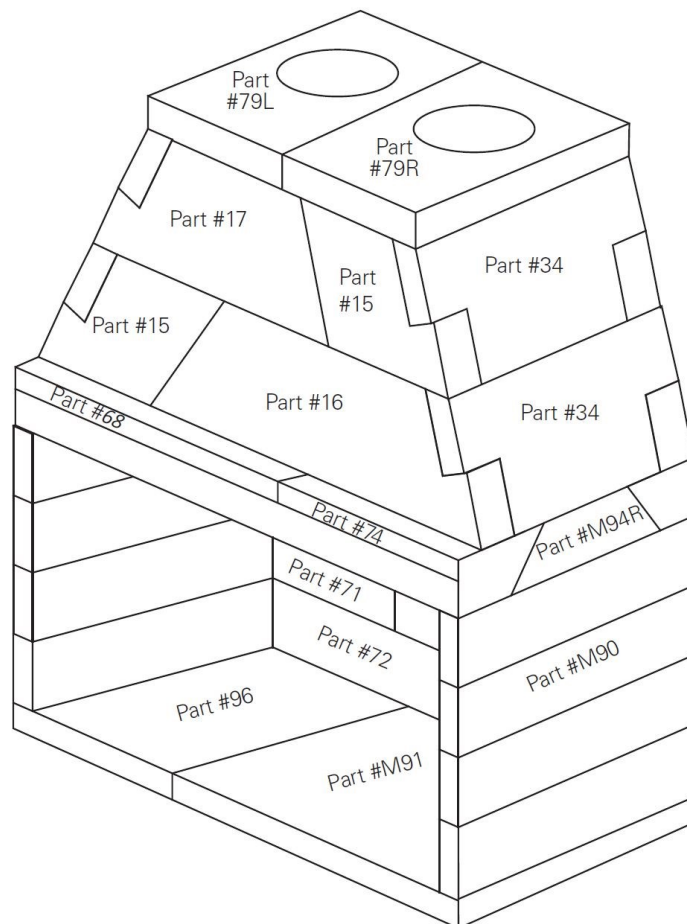

FIGURE 26

Assembly Instructions – MAGNUM 72

The following assembly instructions identify the parts by name, part number and the placement of each part in the assembly process.

NOTE: At all component placement, be sure to apply Earthcore Adhesive to all contact surfaces. Check for complete sealing of each contact joint while assembly progresses.

1. Apply Earthcore adhesive to the joint between the two #M91's and set the base plates in a full bed of Earthcore Adhesive on a level support surface. See page 14 for supporting floor system. **(Figure 27)** Do not set the base plate so that it is in span. The overall length of the base plate assembly should measure 85½" and 28" deep.

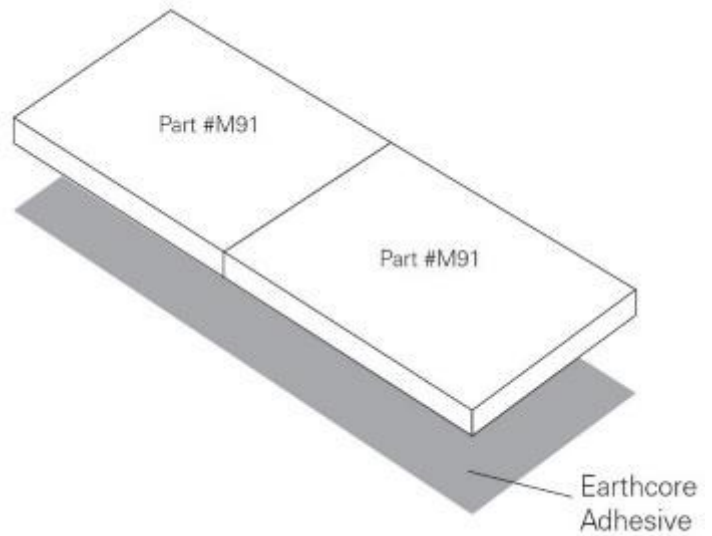

FIGURE 27

Flush Hearth:

If the design preference is for a “flush hearth” the base plate can be omitted from the assembly and the firebox walls built directly on a minimum 4" concrete support slab. The fire brick floor of the firebox is then set directly to the concrete support slab. This makes the fireplace finished fire brick floor approximately one and one-half inches (1-1/2") above the top of the concrete support slab.

Raised Hearth:

If the design preference is for a raised hearth (floor of the fireplace elevated above the room’s floor), then the base plate can be set on a noncombustible platform that is built up to the desired raised hearth height on the concrete support slab.

When calculating raised hearth height be sure to allow for the three inch (3") thick base plate plus the one- and one-half inch (1-1/2") thick fire brick floor in addition to the height of the platform.

For all “raised hearth” construction where concrete blocks are used to create the raised platform, it is necessary to use the base plate. Be sure to Earthcore adhesive the concrete block platform together. CMU used for base plate support should be rated ASTM 90.

Whether a flush hearth or a raised hearth is installed, all MAGNUM 60/72 Series fireplaces shall have hearth extensions of approved non-combustible material such as brick, tile, or stone that is properly supported and with no combustible material against the underside thereof. This noncombustible hearth extension shall be set tight against the fireplace front and extend at least 30 inches out from the finished fireplace and at least 12" beyond the finished sides of the fireplace opening.

2. Set the first course of the firebox side walls and back walls into place. **(Figure 28 and 29)**

NOTE: It may be convenient to dry set the first course of side walls and back walls into place on the Isokern base plate and then trace their position on the base plate with a pencil.

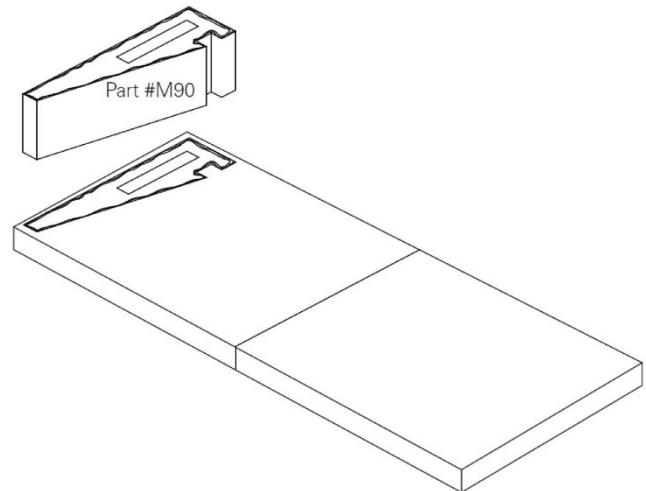

FIGURE 28

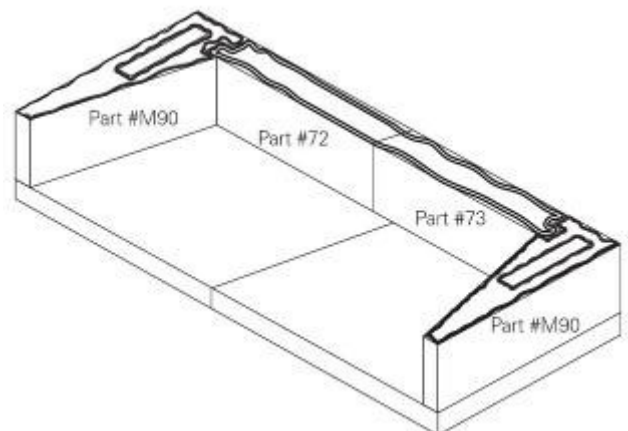

FIGURE 29

Assembly Instructions – MAGNUM 72

After outlining the dry set pieces, remove them and apply Earthcore adhesive to the areas traced on the base plate where the side walls and back wall are to sit. By doing this, the first layer of wall components can be set directly into Earthcore adhesive already applied to the proper areas on the base plate.

- Continue assembly of the consecutive courses of the firebox side wall and back wall, making sure to stagger the backwall components so that the vertical joints do not align. Apply Earthcore adhesive to the top of each layer of wall components, set the next course above into place. Be sure to Earthcore adhesive all vertical joints of the side walls, as well as the sidewall to back wall connection when setting each component to its mate (**Figure 30**)

Look for some Earthcore adhesive to squeeze out along the joints of all contact surfaces as a sign that the joint is thoroughly sealed with the approved Earthcore adhesive.

- When all the firebox sidewall and backwall components are set, check the top surface of the firebox for level. If necessary, adjust the top surface of the box assembly for level by inserting a shim supplied with the unit between the lowest wall component and the top surface of the base plate.

Any gap created under the wall components during the shim leveling process must be filled with Earthcore Adhesive to fill bearing against the base plate.

- Steel angle iron with measurements of 4" x 6" x 3/8" cut to 85½" long to span firebox opening will be needed to assemble the firebox. **This item is not included in the components and can be sourced locally.**

This steel angle sits on top of the uppermost side wall component with the four-inch leg in the horizontal position. To avoid a thickness problem with the placement of the steel angle it is necessary to cut a notch in the top side wall component where the angle is to sit. This notch should be cut approximately 3/8" deep. The notch should start at the front face of the side wall component (at both the left and right hand walls) and run to a point 4" back toward the firebox. (**Figure 31**)

The steel angle sits in this notch. The six-inch leg of the steel angle is in the vertical position and is to be located in alignment with the front of the firebox. The ends of the steel angle should not protrude beyond the outer firebox side wall. Earthcore adhesive between the steel and the notch in the top of the side wall is not needed.

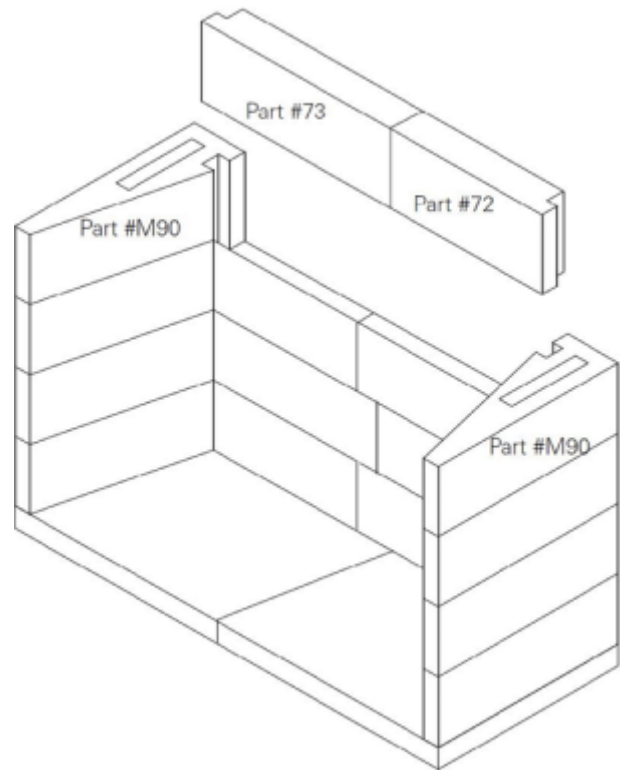

FIGURE 30

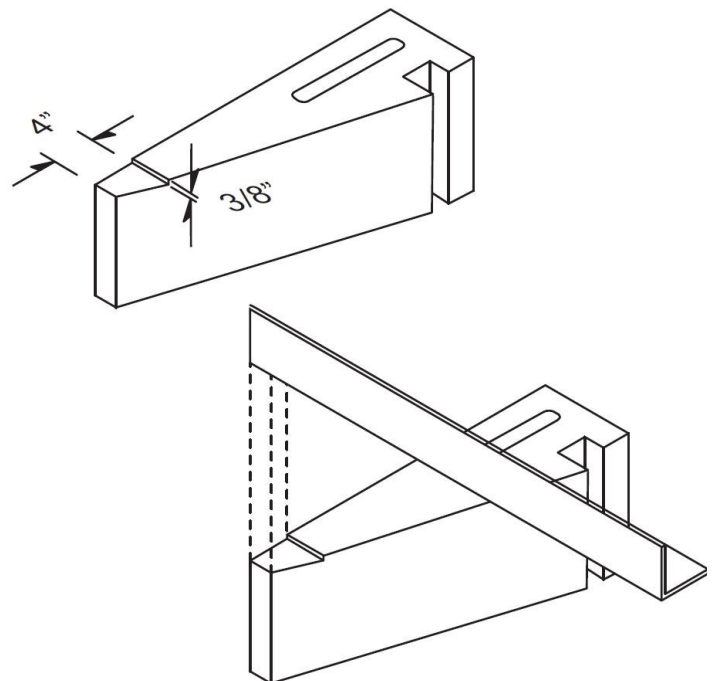

FIGURE 31

Assembly Instructions – MAGNUM 72

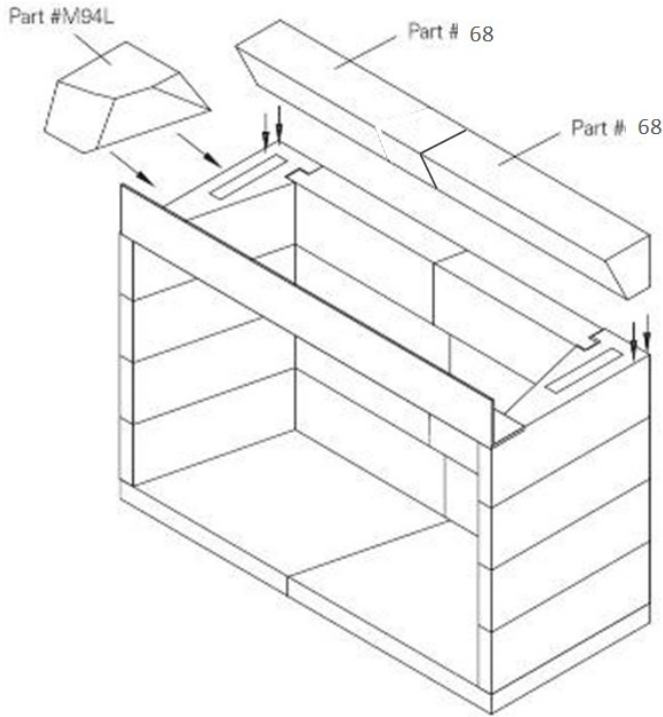

FIGURE 32

6. The fireplaces come with an eight-inch (8”) thick damper beam assembly, a six (6) piece component group that is to be assembled on top of the firebox sidewalls and backwall.

The damper beam assembly consists of four (4) long lintel pieces and two (2) short damper beam side pieces.

The damper side pieces are designed to sit on the firebox side wall between the front lintel and the back lintel. Each of the damper side pieces is designed specifically for its own side of the unit.

When properly set, each damper side piece fits flush with the outside face of the firebox sidewall so that its interior bottom edge aligns with the interior angle of the firebox side wall that it sits on. **(Figure 32)**

When part# 68 and part# 68 are put together they will be equal to the width of the fireplace. Properly placed, the lintel is to sit on top of the firebox back wall and flush with it; the other lintel sits flush with the front of the firebox, spanning the firebox opening. These components both sit on their narrow base so that their beveled face points down and into the firebox interior. **(Figure 33)**

Be sure to Earthcore adhesive all damper beam components to the top surfaces of the firebox. Earthcore adhesive the contact surfaces of each damper side component where it meets the front and back damper beam lintel components.

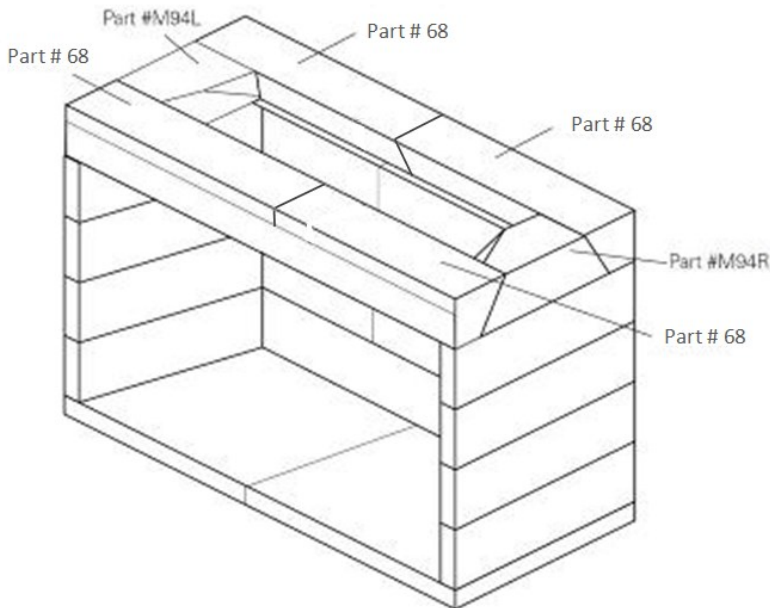

FIGURE 33

NOTE: The firebox and smoke dome are designed to be fitted with a traditional cast iron, poker-style throat damper that is placed on top of the damper beams during installation. In-line, bottom mount, or chimney top dampers are alternative options. The damper is not included with the firebox.

With the damper beams assembled together with Earthcore Adhesive, set the cast iron throat damper (unless another damper type is being used) on top of the damper beam and over the smoke chamber opening. The cast iron damper’s operating plate should face toward the rear of the fireplace. The flange at all four sides of the cast iron damper should be supported by the damper beam’s top surface.

Run a thin bead of Earthcore Adhesive around the four sides of the cast iron damper or tack the corners of the flange to avoid movement of the damper as it gets opened and closed.

Assembly Instructions – MAGNUM 72

7. Set the rear smoke dome components across the damper beam in a bed of Earthcore adhesive and flush with the back face of the back damper beam lintel.

Set the front smoke dome components in Earthcore adhesive across the front damper beam and 2 -3/4 inches back from the front of the front damper beam lintel. This placement should create a space of 17 inches (17") between the front and rear smoke dome components. **(Figure 34)**

8. Position the smoke dome's sloping sidewalls at each end of the smoke dome components. The sloping sidewalls fit in between the front and rear smoke dome components and also fit into the haunches at the ends of the front and rear smoke dome components. Earthcore adhesive all contact surfaces thoroughly. The smoke dome sloping sidewalls have a beveled bottom edge so that they will sit tight onto the flat top of the damper beam assembly. **(Figure 35)**

9. Set the second tier of rear smoke dome components across the top of the first tier of smoke dome components with Earthcore adhesive between the two tiers. Make sure both tiers are flush with one another.

Follow the same instructions of the second tier of rear smoke dome components for the second tier of front smoke dome components. This placement should create a space of 17 inches (17") between the front and rear smoke dome components. **(Figure 36)**

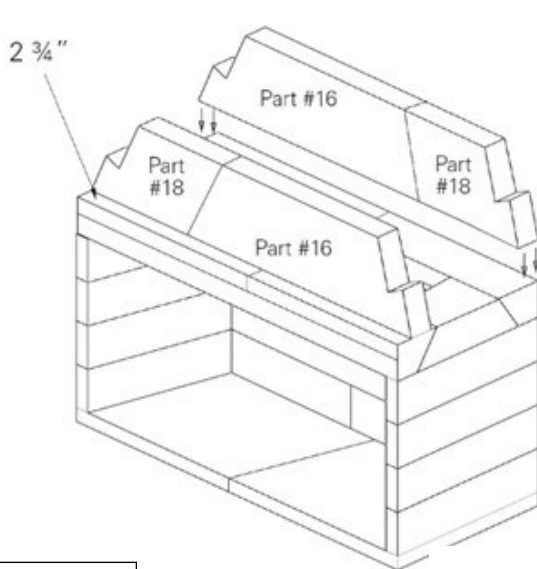

FIGURE 34

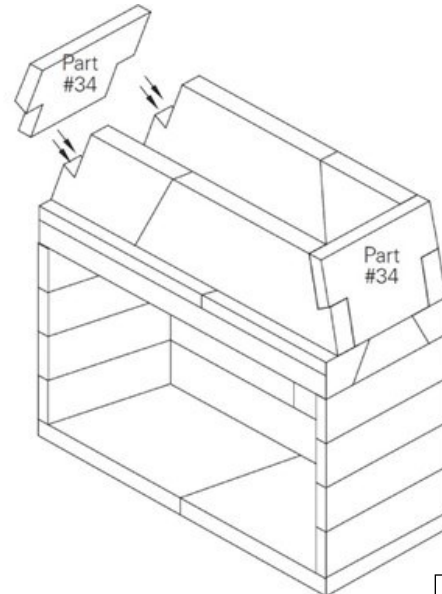

FIGURE 35

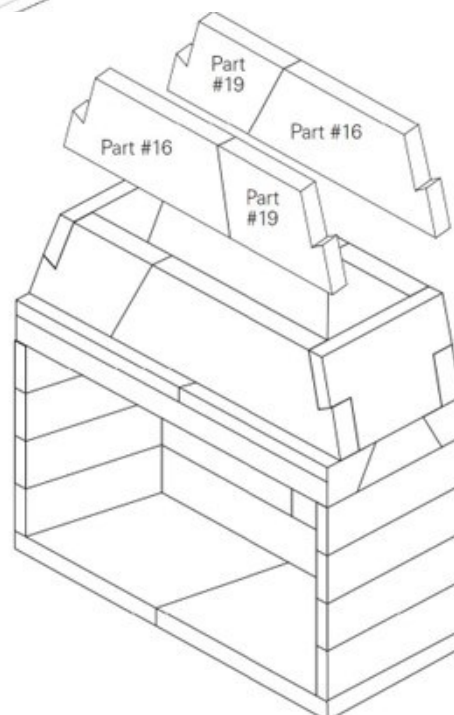

FIGURE 36

Assembly Instructions – MAGNUM 72

- Position the second tier of smoke dome's sloping sidewalls at each end of the smoke dome components. The sloping sidewalls fit in between the front and rear smoke dome components and also fit into the haunches at the ends of the front and rear smoke dome components. Earthcore adhesive all contact surfaces thoroughly. The smoke dome sloping sidewalls have a beveled bottom edge so that they will sit tight onto the flat top of the damper beam assembly. **(Figure 37)**
- Apply Earthcore adhesive to the top of the smoke dome wall assembly and set the two top plates into position.

NOTE: One side of the top plate shows a thickened center. This side is the bottom face.

NOTE: When oriented properly on top of the firebox, the center of the flue outlet will be ten and three-fourths inches (10-3/4") from the back of the firebox and centered from left to right. **(Figure 38)**

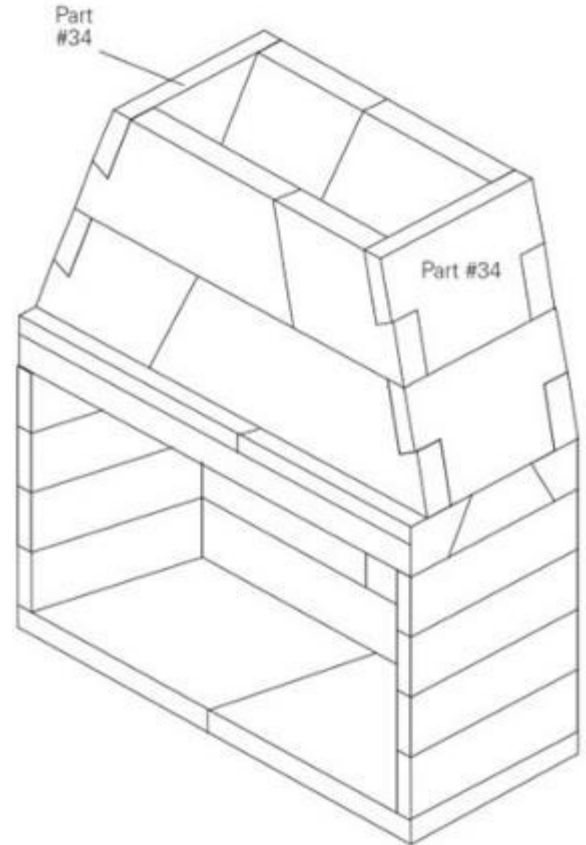

FIGURE 37

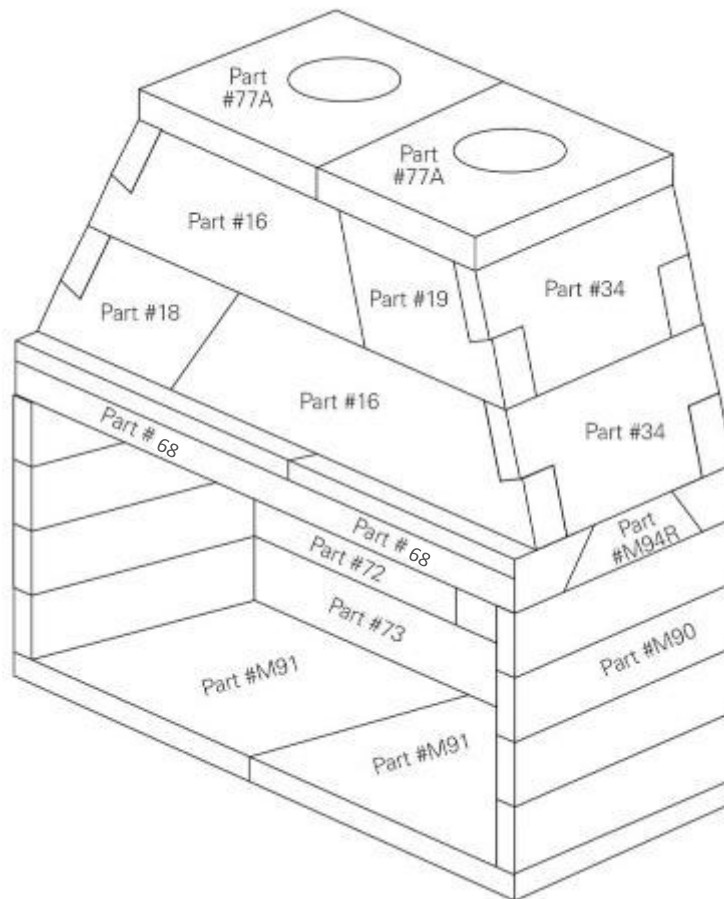

FIGURE 38

DM Chimney Components & General Information

The DM chimney is a dual module, refractory masonry chimney system. It is composed of two precast mating components; the outer casing liner, and an inner liner.

This chimney system is designed for installation in accordance with the National Fire Protection Standard for Chimneys and Solid Fuel-Burning Appliances, NFPA 211 and in accordance with codes, such as ICC, BOCA Basic/National Codes, the standard Mechanical Code, and the Uniform Building Codes.

Required DM Chimney Clearance

The DM chimney system, rated UL 103HT, is listed for zero clearance to normal construction materials. The DM chimney system may be enclosed in a wood chimney chase at zero clearance to wood framing members.

Since lateral support is required for DM chimneys the framing members will be in contact with the DM chimney system.

IMPORTANT: “Combustibles” are defined as “normal construction materials” and are considered to be framing materials, particle board, mill board, drywall, plywood paneling, plywood sub flooring, and wood flooring.

Keep all insulation, vapor barriers, “house wrap” paper and other insulating type membranes and products, including fiberglass, cellulose, and other insulation (anything that carries an “R” rating) a minimum of three inches (3”) away from all firebox and chimney surfaces.







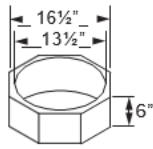
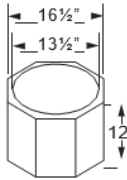
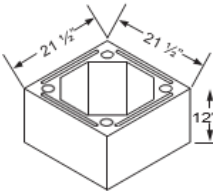
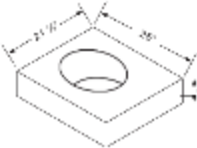

EXCEPTION: If insulation is used in walls surrounding the fireplace, insulation may be installed behind sheathing of gypsum board, plywood, particle board, or other material on the side facing the Isokern. The facing material cannot be within 1-½” to the fireplace side walls.

Mechanical Vent Systems

It is acceptable to use mechanical draft systems, if the venting companies do the engineering calculations and make the necessary recommendations for fan size and flue vent diameter following the guidelines of NFPA 211, page 211-13. Installation of such systems must also follow the mechanical drafting company’s explicit installation and operation instructions.

Isokern DM Chimney Weights

Total installed chimney weight will vary and be based on the overall height and the configuration of the chimney system. Chimneys may be straight vertical stacks of DM outer casing and inner liner (**see page 3**) but may also include the use of offset chimney blocks, brick ledge, chimney reinforcement, brick/stone veneers, cement crown caps and clay chimney pot termination with additional structural support.

Component	Part#	Description
	70003	Isokern DM Chimney 6” Starter Inner Liner
	70235	Isokern DM Chimney 12” Inner Liner
	45433	Isokern DM Chimney 12” Outer Casing
	40136	Isokern DM Chimney Offset Block
	40111	Isokern Brick Ledge
	40322	Isokern Small Crown Cap
	40323	Isokern Large Crown Cap
	50001	ISO-Cap Spark Arrestor - Stainless Steel
	50003	ISO-Cap Spark Arrestor w/ Damper - Stainless Steel (Shown) Fits Inner Liner
	50004	ISO-Cap Spark Arrestor - Black Galvanized Fits Outer Liner
	50006	ISO-Cap Spark Arrestor - Copper Fits Inner Liner

DM Chimney Components: Weight & Height Requirements

Part	Weight
Small crown cap:	80 lb.
Large crown cap:	100 lb.
Brick ledge:	110 lb.
6" Inner Liner:	19 lb.
12" Inner Liner:	45 lb.
Outer Casing:	90 lb.
Offset block*:	110 lb.

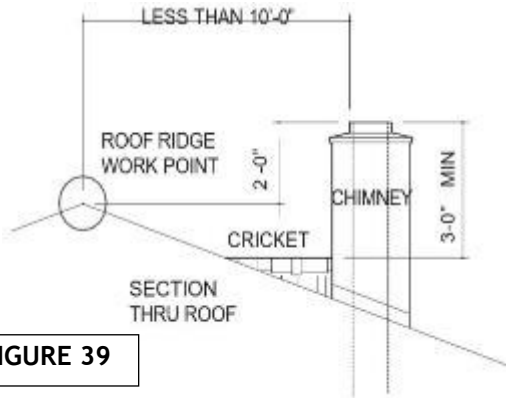

FIGURE 39

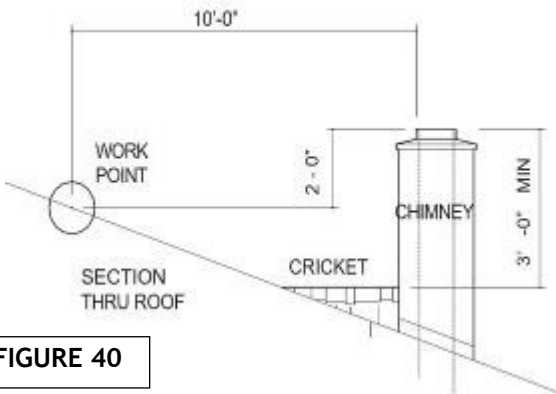

FIGURE 40

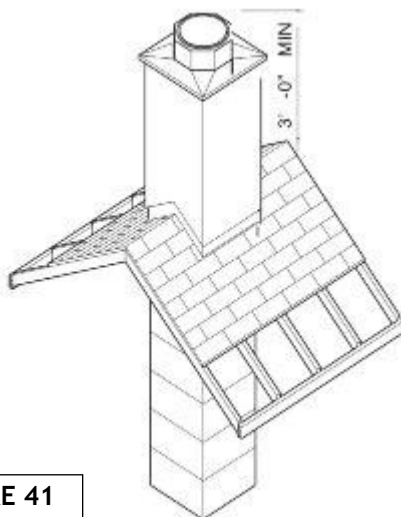

FIGURE 41

The DM chimney component weights are as shown in the table at left.

The required minimum chimney height above the roof and adjacent walls and buildings is specified by all major building codes and is summed up in what is known as “the 2-foot in 10-foot rule”:

1. If the horizontal distance from the roof ridge to the opening of the chimney is less than 10’, the top of the chimney must be at least 2’ above the roof ridge.
2. If the horizontal distance from the opening of the chimney to the roof ridge is more than 10’ then a chimney height “work point” is established on the roof surface 10’ horizontally from the opening of the chimney. The top of the chimney must be at least 2’ above this work point.
3. In all cases, the chimney cannot be less than 3’ above the roof at the edge of the chimney. **(Figures 39 & 40)**

A simple example of this would be if the roof is flat then the chimney would need to be at least 3’ above the roof surface. Or, if the chimney penetrates the roof at the ridge, then the chimney must be at least 3’ above the ridge. **(Figure 41)**

NOTE: The “2 foot in 10 foot rule” is necessary in the interest of fire safety but does not ensure smoke-free operation of the fireplace. Trees, buildings, adjoining roof lines, adverse wind conditions, etc. may require a taller chimney for the fireplace to draft properly.

NOTE: As with all chimney installations, avoid overhead obstructions such as trees, power lines, etc...

DM Chimney Installation: Straight Run

Where the chimney run is to be straight run, start the DM chimney by setting a DM outer casing in a bed of Earthcore adhesive on top of the top plate. The outer casing is to be centered from side-to-side and flush with the back of the top plate. Be sure that the outer casing aligns with the flue hole in the top plate. The DM outer casing will sit three and three fourths’ inches (3-¾”) back from the front face of the top plate.

This total set-back distance makes it possible for a three and one-half inches (3-½”) thick bearing header to pass over the MAGNUM 60 & 72 firebox smoke dome assembly and for the DM chimney to run straight up the back side of the bearing header. **(Figure 42)**

Next set the DM chimney inner liner’s six inch (6”) tall “starter” piece inside the first outer casing. The six inch (6”) tall inner liner has a female end and a flat end. Set this inner liner with the flat end down. Be sure that the stater piece is set into the Earthcore adhesive so it is fully sealed to the top plate.

IMPORTANT: Earthcore adhesive all outer casings together and Earthcore adhesive all inner liners together. **DO NOT** Earthcore adhesive the air space between the liners and the outer casing blocks.

DM Chimney Installation: Straight Run

NOTE: For every 12' of DM54 Flue you should order a bucket of Earthcore Adhesive MP50

Starting with the six inch (6") tall inner liner starter piece creates six inch (6") staggered horizontal joints between the inner liner and the outer casing as the chimney is built up.

Both the outer liner and the inner casing components have tongue and groove type detailing on each end to assure alignment and interlock of the pieces as they are stacked and adhered together.

NOTE: If the six inch (6") inner liner starter piece is broken or otherwise unavailable, a full twelve inch (12") tall inner liner piece can be cut to six inches (6") in height to make an inner liner starter piece.

After setting the DM inner liner starter piece, apply Earthcore adhesive to the top of the starter liner. Continue the straight chimney run by placing a full height inner liner onto the six inch (6") starter liner. The top of this full height inner liner will sit 6" above the top of the outer casing block that was previously set.

This six inch (6") offset between joints of the inner liner stack and the joints of the outer casing stack continues to the top of the chimney run. **(Figure 43)**

Continue the straight vertical DM chimney by setting an outer casing onto a bed of Earthcore adhesive on the top surface of the preceding outer casing. The grooves on the bottom end of the upper outer casing fit onto the tongues on the top of the lower outer casing block. This assures proper alignment of the two components.

Next place a full height inner liner onto a bed of Earthcore adhesive on the top end of the previously set inner liner. Proceed this alternate stacking of outer casing and inner liners until the desired height of the flue is attained.

Lateral Support for DM Chimneys

Though not required, it is recommended that where the DM chimney is built up along an exterior wall the vertical chimney system can be connected to the structural wall system at a minimum of four foot (4') intervals. This connection can be made using 18 gauge strap ties (Simpson Strong Tie CS coil strap, or equivalent).

Starting on one side of the DM chimney, at four foot (4') intervals up the structural wall adjoining the chimney, connect one 18 gauge strap tie to the structural wall with two, three inch (3") #8 (minimum) wood screws or masonry anchors, as appropriate.

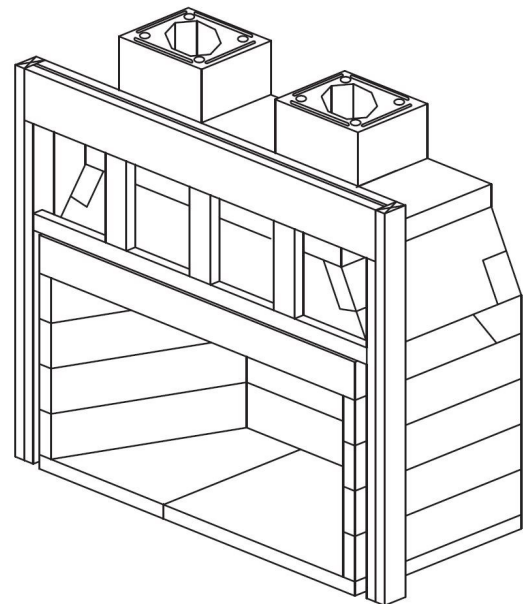

FIGURE 42

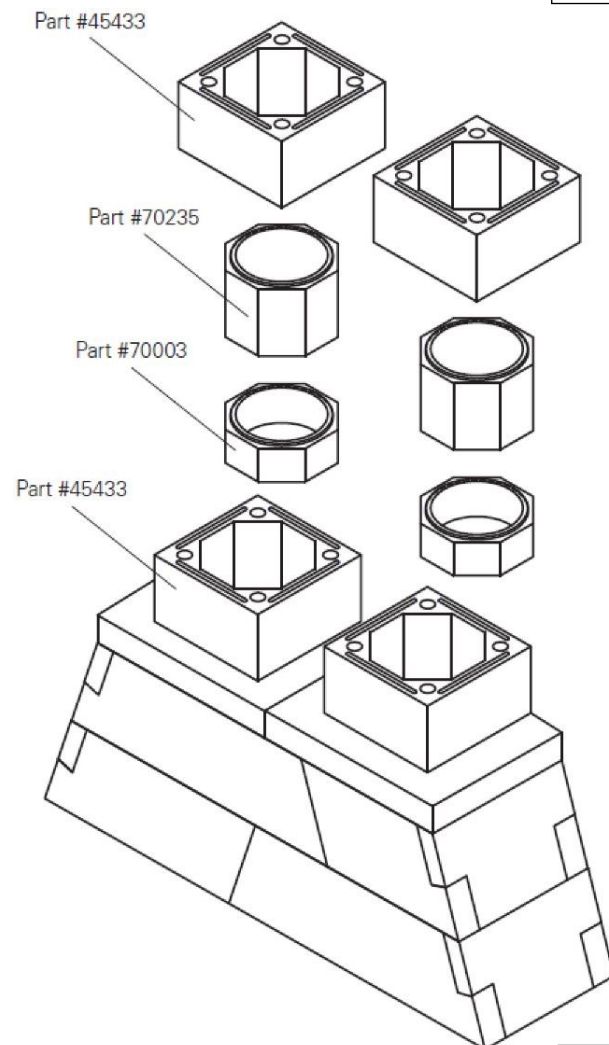

FIGURE 43

DM Chimney Installation - Straight Run

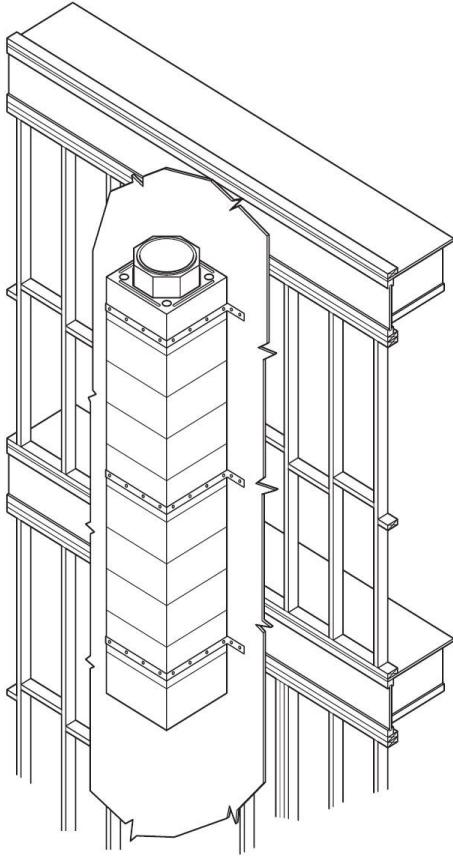

FIGURE 44

Next fold the strap around the three exposed sides of the outer casing. Connect the strap to each of the three outer casing faces with two (2) one and one-half inch (1-1/2") long masonry anchors, such as "Tapcon" or "Titen" screws. Fasten the strap back to the structural wall with two three-inch (3") # 8 (minimum) wood screws or masonry screws, as appropriate. **(Figure 44)**

Where DM chimneys are built up from the interior walls the DM chimney outer casing block is to be laterally braced at ceiling and roof penetrations.

Pressure treated two-inch (2") by four-inch (4") blocks, set at each side of the flue between the trusses or rafters and fastened to the pre-engineered roof trusses or rafters with two 16d common nails at each end, provides lateral support, parallel with the framing.

Additionally, a two inch (2") by four-inch (4") by six-feet (6') minimum pressure treated member ("rat run") installed on each side of and butted up to the outer casing block will provide lateral support perpendicular to the direction of the truss or rafter framing system.

Fasten the perpendicular member with two 16d common nails to each intersecting truss or rafter. The perpendicular bracing should be installed on the top side the ceiling level framing as well as on the bottom side of the rafters. **(Figure 45)**

DM Chimney Installation - Offset Run

DM Offset Block

For vertical DM chimney to bypass overhead obstructions, the Isokern offset chimney block is used. Offset blocks are six-inch (6") thick, single module chimney components, measuring twenty-one and one-half inch (21-1/2") wide by twenty-five inches (25") long. The fourteen-inch hole passes through the block at thirty (30°) degrees. An offset chimney block can be set as the first flue component on top of the top plate.

Offset chimney block sequences can be built to shift the chimney run to the left, right, or to the rear of the firebox/smoke dome assembly.

Offset blocks can be set in a spiraling rotation, thus moving the chimney to a point that is diagonally away from its starting point.

NOTE: Offset blocks require one and one-half inches (1-1/2") clearance to combustible framing.

DM Chimney Offset Block Installation and Support Foundations

Isokern offset chimney blocks are stacked in a stair step fashion with each successive block overhanging the previous offset block by three inches (3"), allowing the flue to rise at an angle of thirty (30°) degrees from vertical. **(Figure 46)**

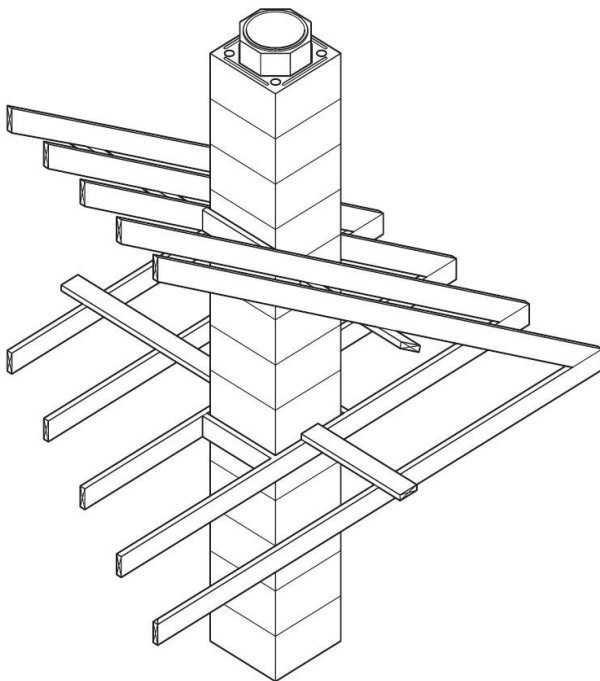

FIGURE 45

DM Chimney Installation - Offset Run

Each offset block is to be set fully in a bed of Earthcore Adhesive, completely sealing each offset block to the underlying component. When placing the first inner liner on top of the last offset required, seal the space between the inner liner and the offset block with Earthcore Adhesive so that no smoke will be able to spill through the two joints.

When building offset sequences, it is necessary to support the third offset block in the sequence and every third offset block thereafter to footings via concrete block or steel support columns. When using only one or two offset blocks no additional support is required. Always support the last offset block in a sequence for full support of the DM chimney where it returns to vertical.

During this building process it is important to check the interior flue alignment as each offset block is set to avoid creating overhanging ledges on the inside of the flue. Such internal overhangs will inhibit flue drafting.

NOTE: Offset sequences should begin directly on top of the firebox at the beginning of the chimney run. If a DM Offset sequence cannot be done at the beginning of the chimney sequence, you must consult a structural engineer to ensure proper support is in place for the DM Chimney Offset.

Plan fireplace and DM chimney systems carefully before foundations are laid to assure that proper footings are available to support Isokern offset blocks chimney run.

To calculate the distance of Isokern offset chimney travel in a straight line to the right, left or to the rear of the firebox/smoke dome assembly, proceed as follows:

Temporarily dry set a DM outer casing block in its proper location on top of the completed firebox/smoke dome assembly as though starting a straight chimney. **(Figure 47)**

If the offset sequence is to move to the left, then, starting from the right side of the temporary DM outer casing measure leftward to the far face of the overhead obstruction that needs to be bypassed by the vertical chimney run.

For accurate measuring drop a plumb line down from the far face of overhead obstruction to the level of the top of the smoke dome assembly. Measure from the far side of the temporary DM outer casing to the plumb line. This measurement, taken in inches and divided by three (three inches of horizontal travel per offset block) gives the total number of offset blocks needed to accomplish the required travel distance.. **(Figure 47)**

To calculate the height that the offset block sequence will require, take the total number of offset blocks needed to accomplish the travel distance (described above) multiplied by 6". This number is the height (inches) that the offset sequence will require.

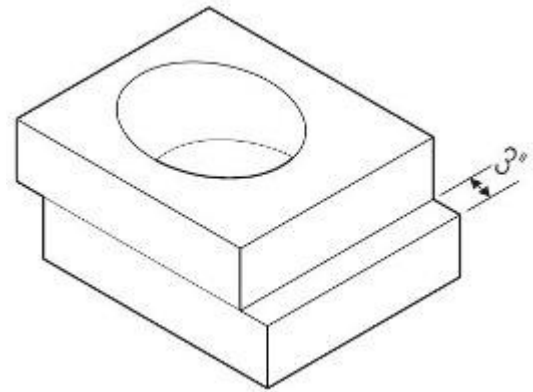

FIGURE 46

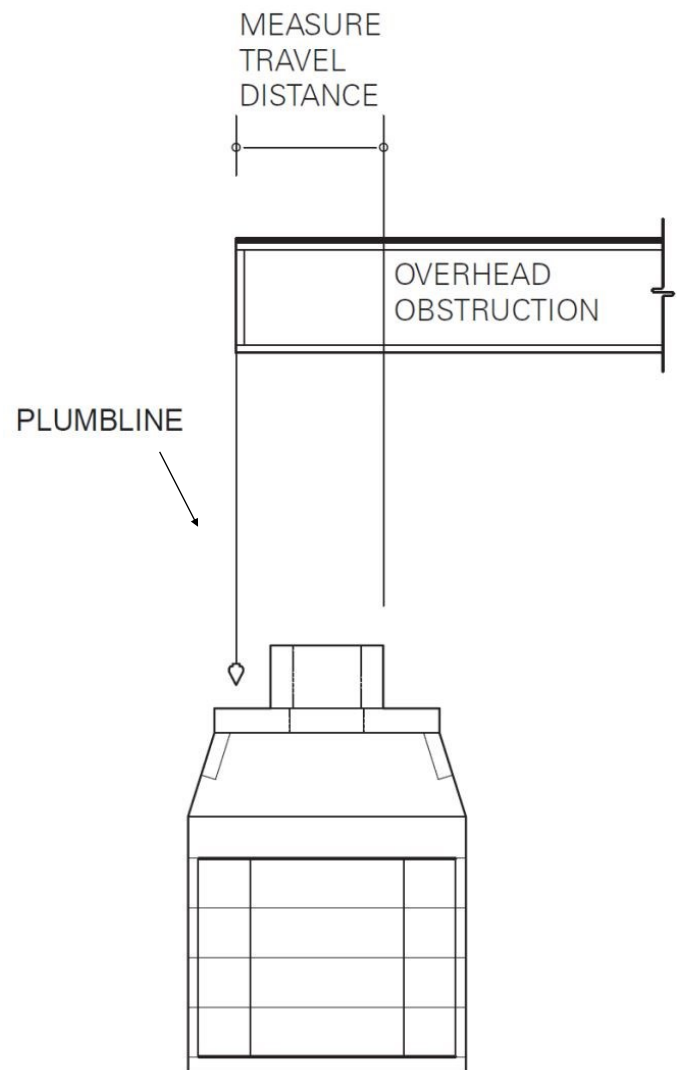

FIGURE 47

DM Chimney Installation - Offset Run

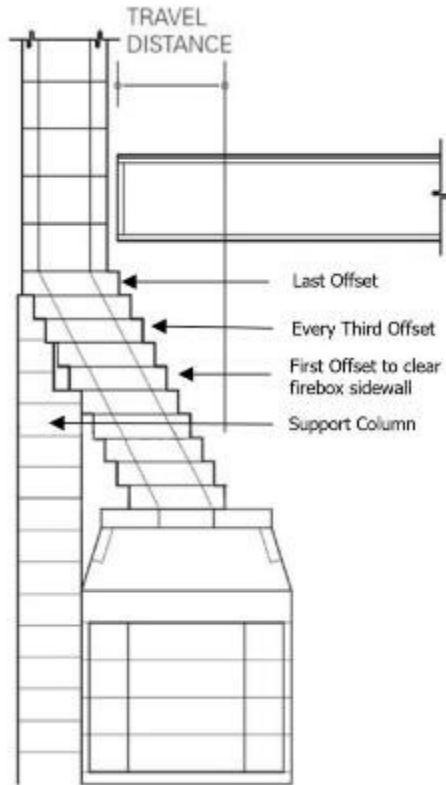

FIGURE 48

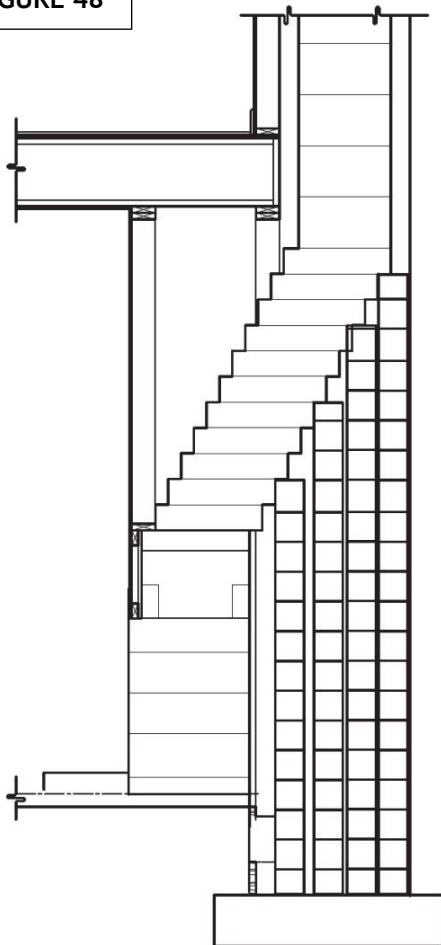

FIGURE 49

When establishing the “far face” of the overhead obstruction, be sure that the DM chimney blocks can run straight to chimney termination without further overhead obstruction since a second offset sequence is not allowed. **(Figure 48 & 49)**

Be sure that there is sufficient space beyond the “far face” of the overhead obstruction to accept the DM chimney’s outer casing dimension of 21-1/2”.

IMPORTANT: Always support the last offset block in a sequence for full support of the DM chimney where it returns to vertical.

Support columns often carry the majority of the total load of the vertical chimney that is set onto the last offset block.

The total chimney weight above the last offset block will be the total weight of the vertical chimney plus any additional allowable loads such as the Isokern brick ledge, its related brick or stone veneers, and any crown caps, clay pots or other masonry chimney terminations.

Be sure the foundation under all support columns is made of concrete or steel and designed to support the loads applied to it. Do not make support columns of brick, stone, or wood. All support columns must bear onto proper non-combustible foundations.

Offsets to the Left or Right:

When offsetting chimneys to the left or right of the firebox it is not possible to build a support column directly under the third offset block as required. To create the proper support for offset chimney block sequences that clear the side wall of the firebox, it is allowable to support the first offset block that clears the firebox side wall and then to proceed with supports at each third offset block thereafter. **(Figure 48)**

NOTE: A noncombustible and removable temporary support structure may be used to support the offset sequence until it clears the firebox sidewall and bears upon the first concrete/steel support column. Once supported, remove the temporary support, and ensure that all contact surfaces and seams are fully sealed with Earthcore Adhesive to prevent smoke spillage between the joints.

To create the proper support for offset chimney block sequences that do not clear the sidewall of the firebox, you must construct concrete or steel support columns against each side of the firebox up to the level of the top plate.

The distance from these columns to the top plate will be spanned with two pieces of four-inch (4”) by four-inch (4”) by five-eighths inch (5/8”) steel angle on each side.

To ensure the steel has adequate bearing distance on the top plate, the first offset block in each sequence will require two 6” x 3-1/2” x 5/8” deep notches to be cut into its underside to accept these angles **(Figure 50, Detail A)**.

IMPORTANT: Ensure that the notches are cut accurately and do not encroach to within 2” of opening on the bottom face of the offset block.

Once the offset(s) have been notched and the angle irons set in position, the offset blocks are set fully in a bed of Earthcore Adhesive. Be sure to completely seal the offset block to the top plate. Ensure the angle irons are set into the notches, are parallel and flush to the sides of the offset block, and bear fully on the concrete or steel support column.

On the steel angles, build a masonry or steel support column up to the underside of the third offset block in the sequence. Ensure that the third offset, as well as the last offset in any sequence are supported. **(Figure 50)**

DM Chimney Installation – Brick Ledge

The DM brick ledge is a 31-1/2" x 31-1/2" x 3" thick, steel reinforced, concrete and pumice slab. It provides a 5" ledge at all four sides of the outer casing block and is designed to support masonry veneers to DM chimneys starting below the rafters and continuing to termination. (Figure 51, 52, 53)

The component is cast with an octagonal hole in its center so that the DM octagonal inner liner can pass through it.

The brick ledge has four 2-1/2" holes through it that align with the hole in each of the four corners of the DM outer casing block. These four holes are provided for reinforcement of the chimney stack by the insertion of #4, minimum, steel reinforcing rods and subsequent grouting. (Figure 51, 52, 53)

The brick ledge is intended for use in chimneys that rise through the roof only where all four sides of the chimney are bounded by the roof.

IMPORTANT: To maintain structural performance the DM brick ledge must not be cut or altered in any way.

DM Brick Ledge Installation

Use of the brick ledge will require a roof framing rough opening of at least 34" in width. The required opening dimension along the length of the rafter, where the chimney is to penetrate the roof line, will increase above 34" relative to the pitch of the roof.

As the DM outer casing and inner liner assembly approaches the roof penetration set an outer casing block to a level of approximately 6" below the low side of the roof framing. (Figures 52 & 53)

The alignment tongues on the top of this outer casing block must be ground off to leave a flat contact surface for the brick ledge. Temporarily leave out the inner liner that fits this outer casing block.

Set the Isokern brick ledge onto the flat top surface of the outer casing in a full bed of Earthcore Adhesive. Be sure to align the four 2-1/2" holes in the brick ledge with the matching holes in the outer casing block below it. Return to setting the next inner liner in the sequence. This inner liner comes up from below and passes through the octagonal hole in the brick ledge. The liner's top end will be approximately 3" above the top surface of the brick ledge. Set the next outer casing block onto the top of the brick ledge in a bed of Earthcore Adhesive.

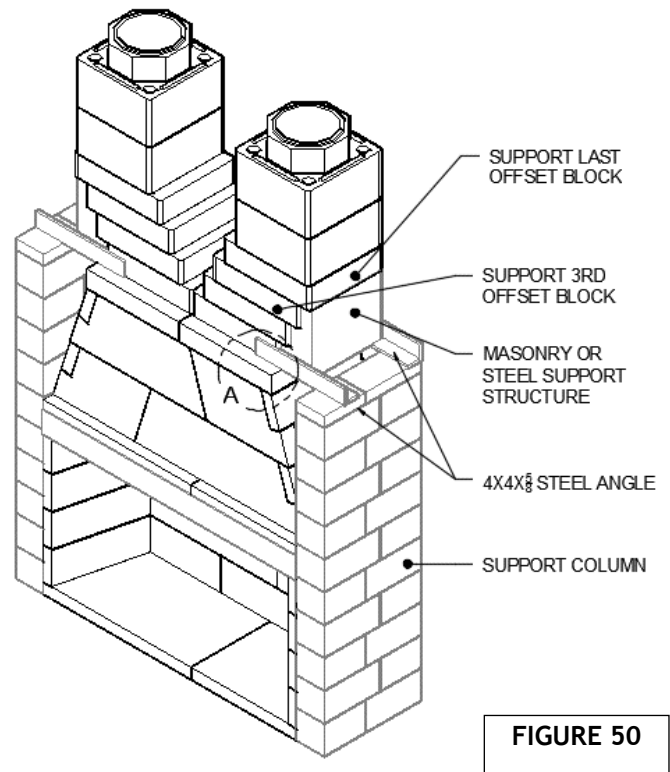
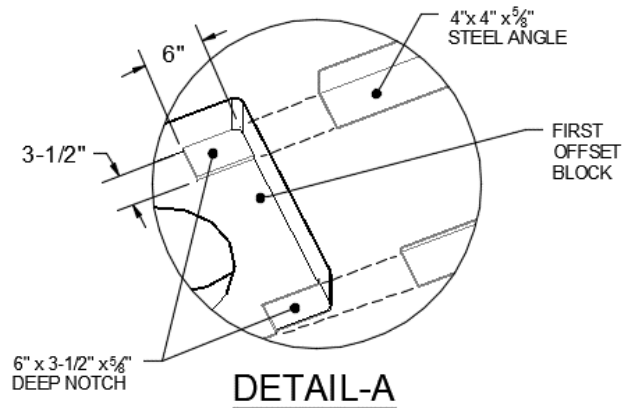

FIGURE 50

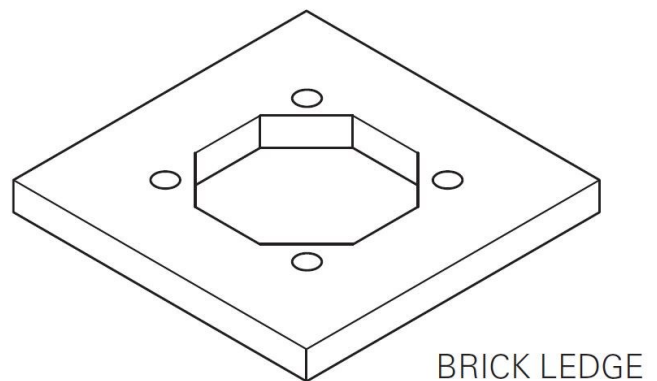

FIGURE 51

DM Chimney Installation – Brick Ledge

Insert one piece of #4 (minimum) steel reinforcing rod into each of the four 2-1/2" holes in the brick ledge. The reinforcement rods must start from a depth of at least 18" below the bottom of the brick ledge. (In some cases, a minimum recommendation could be 5')

Consult local structural engineer for proper job specific support structure design, sizing and load bearing specifications for the MAGNUM Models 60 & 72.

If short lengths of steel rods are used be sure to properly lap and wire tie all splices in the rebar. As the reinforcing progresses, completely fill the holes with grout. Suitable grout can be a pourable mixture of Portland cement and sand or Portland cement, sand and pea gravel. The rebar must be fully embedded in grout.

Leave enough of the #4 steel reinforcing rod exposed above the brick ledge so that as the stacking of outer casing blocks continues to termination the reinforcing rods and grout can continue through the stack. Reinforcing shall continue to chimney termination.

All DM chimneys that include the DM brick ledge must be reinforced as described above.

NOTE: When installing the MAGNUM 60 Fireplace the Isokern Brickledge will NOT work due to space constraints of the two DM 54 Chimney Flues without the use of chimney offset blocks. A six-inch offset is needed on both DM 54 Chimney Flues to use the Brickledge. If you have any questions or concerns, contact the technical department at 1-800-642-2920.

CAUTION: When using the Isokern brick ledge it is required that the MAGNUM 60 & 72 firebox/smoke dome assembly include the placement of a 4" by 6" by 3/8" minimum steel angle across the firebox opening.

Lateral Support for Isokern Brick ledge Chimneys

Once the DM chimney and brick ledge are assembled and after the intended masonry veneer has been installed on the brick ledge, be sure to brace the chimney following the guidelines of this manual for Lateral Support of DM chimneys.

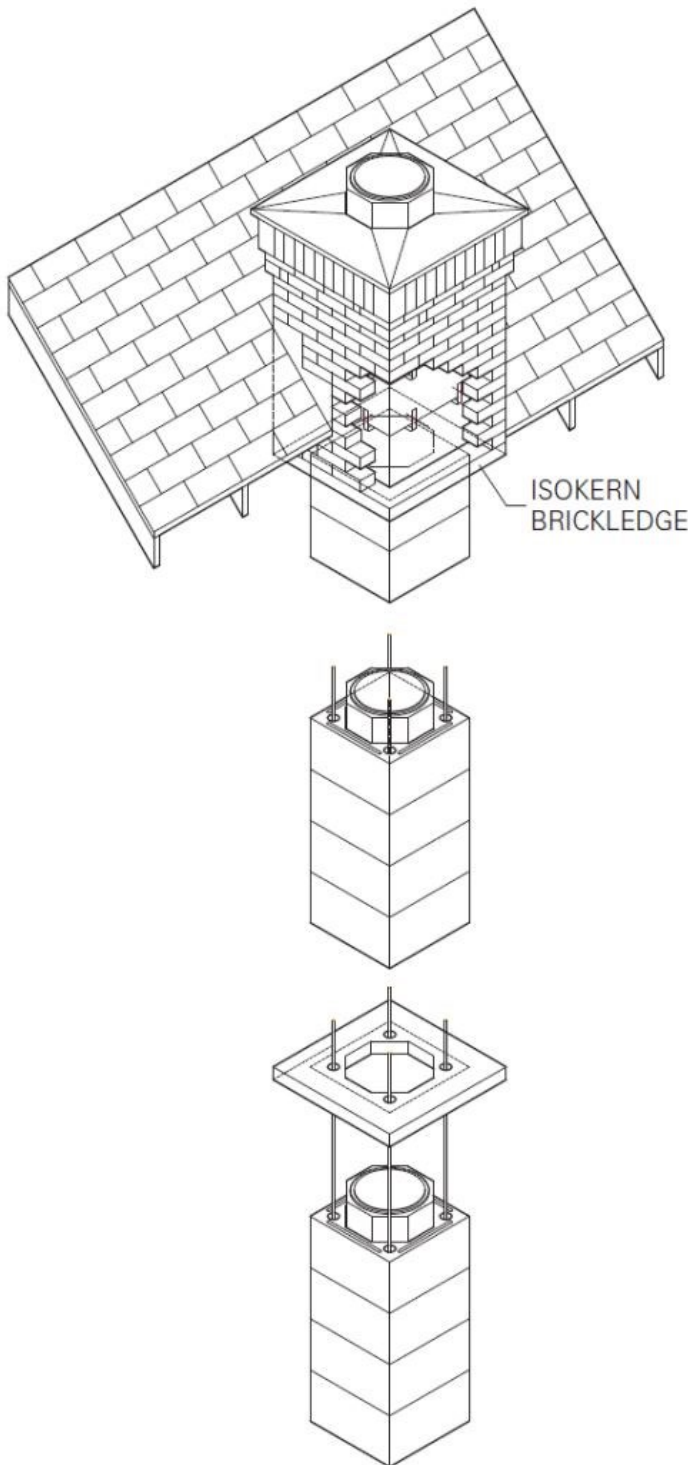

FIGURE 52

DM Chimney Installation – Brick Ledge

Load Capacity for DM Brick ledge

The sources of load delivered into the Isokern brick ledge are: (1) the total physical load of brick, stone, or other masonry veneer on the brick ledge, and (2) loading due to the force of wind delivered against the exposed height of the chimney mass.

The required height of any chimney is governed by applicable local building codes. The overall finished height of any chimney varies based upon site-specific conditions (e.g., elevation of roof line, roof pitch, distance of the chimney from the ridge, etc.).

It is relatively simple to calculate the total physical load on the brick ledge resulting from the physical weight of applied veneers built to code height. However, calculation values for load to the brick ledge due to wind are site specific and based on local variables such as wind speed zone, exposure classification, eave height and roof pitch of the structure, as well as height of chimney mass exposed to wind.

IMPORTANT: The total load delivered into the brick ledge is job specific and will be the sum of:

1. the physical load from veneers, plus
2. the load due to wind.

The total physical load and load due to wind must not exceed ninety-four hundred (9400) pounds.

IMPORTANT: Do not subject the brick ledge to unequal loading when applying veneers. Build veneers equally on all four sides of the brick ledge.

Brick Ledge Veneer Finish and Flashing Details

When applying brick, stone, or other masonry veneer to the Isokern brick ledge standard good building practices for masonry veneer work should govern weather-proofing details and the placement of flashings.

A typical flashing detail would be to field-fabricate an aluminum or galvanized sheet metal flashing, approximately thirty-two inches (32") square with a twenty inch (20") square hole in it, to serve as an inner flashing.

Place the inner flashing on the first DM outer casing block that fully clears the roof line. Keep the flashing to about one-half inch (1/2") lap onto the top of the outer casing block. The twenty inch (20") square hole in the flashing should fit to the outside of the alignment grooves on top of the DM outer casing. Continue the DM chimney up to the required termination height.

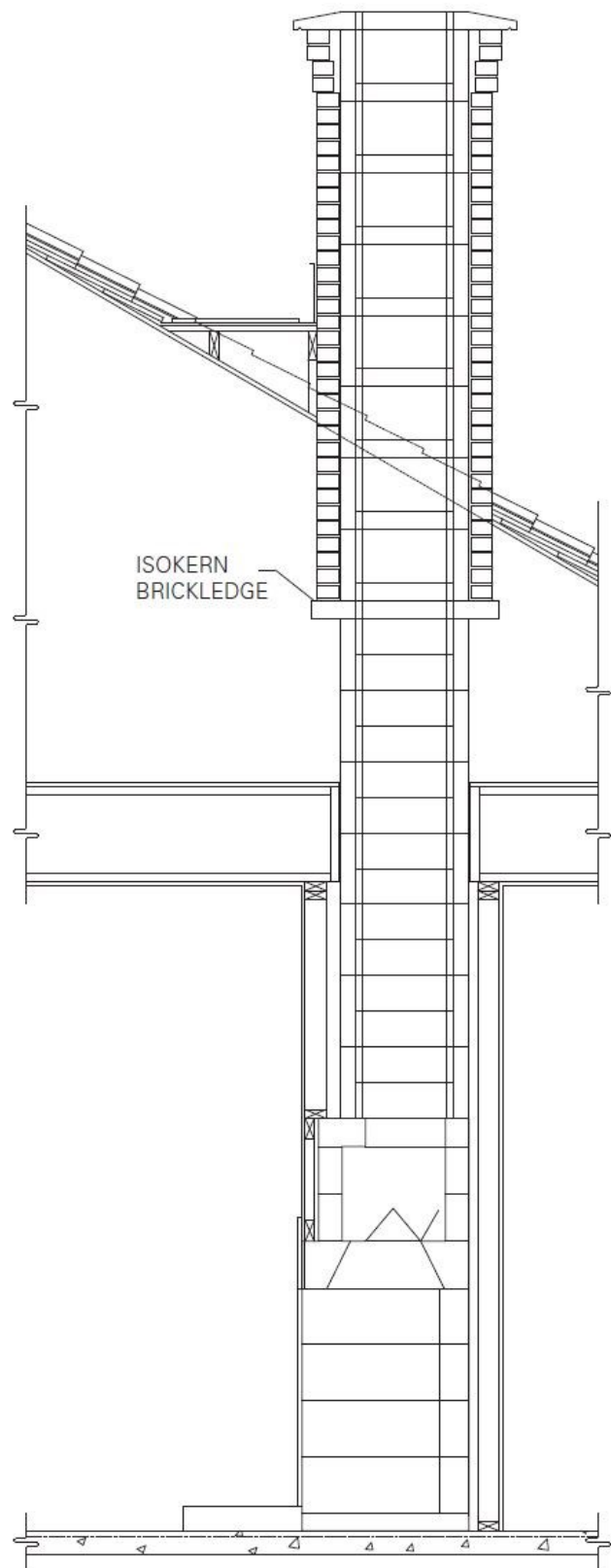

FIGURE 53

DM Chimney Installation – Brick Ledge

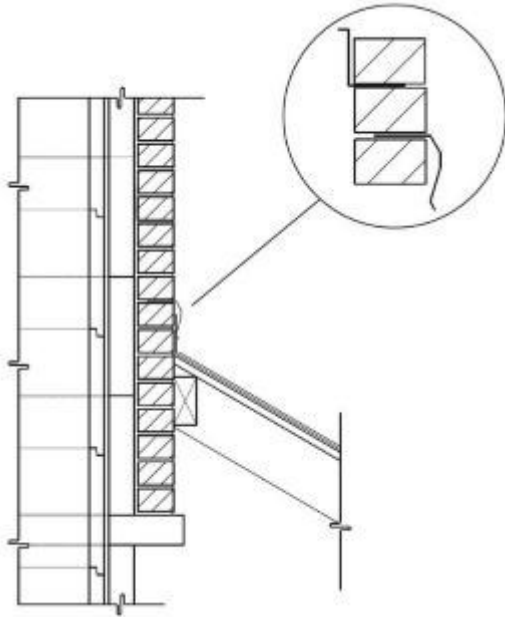

FIGURE 54

Once the masonry veneer is in progress the inner flashing is set into a horizontal joint in the veneer at a level above all other roof deck flashings, chimney-to-roof flashings and counter flashings. Weep holes should open to the outer face of the veneer at vertical mortar joints located at the level of the inner flashing. **(Figure 54)**

Where moisture may develop between the DM outer casing and the chimney veneer, inner flashings as described above will help to divert such moisture to exterior face of the veneer by way of the weep holes and thereby keep such moisture from working its way down between the veneer facing and the DM outer casing and into the interior of the structure below.

DM Chimney Installation – Crown Caps

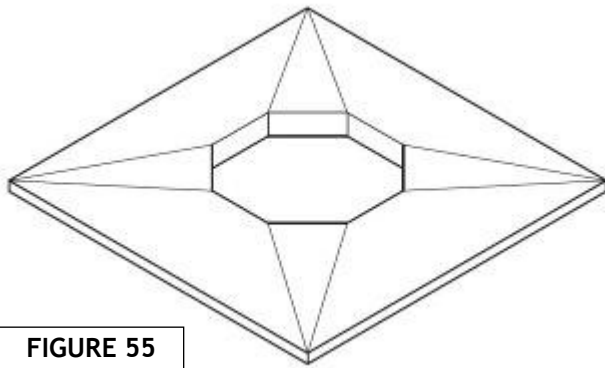

FIGURE 55

DM Large Crown Cap

The DM large crown cap is a prefabricated cement weather cap for masonry veneer chimneys. The large crown cap measures 37-1/2" square and is 3" thick at its center. **(Figure 55)**

The component has an octagonal hole at its center so that the top inner liner of the DM chimney stack can pass through it. The crown cap then sits on the topmost DM outer casing block.

To set the large crown cap the last inner liner should be at least 3" above the last outer casing block in the chimney stack.

Mortar the top of the last outer casing block. Set the large crown cap over the inner liner and onto the top of the last outer casing in the stack.

Caulk or mortar the joint between the octagonal liner and the crown cap where the liner comes through the top surface of the large crown cap.

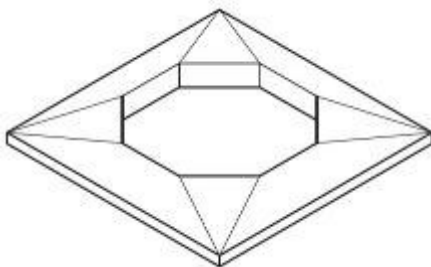

FIGURE 56

DM Small Crown Cap

The DM small crown cap is a prefabricated cement weather cap that measures 26- 1/2" square and 3" thick. The small crown cap is designed and installed the same as the large crown cap. **(Figure 56)**

The small crown cap is intended for use where DM chimneys are to receive thin veneers and cultured stone that do not require the installation of the Isokern brick ledge. The small crown cap is also suitable where DM chimneys are to receive a stucco finish. Other chimney terminations are possible with DM chimneys. Check local codes for use of custom chimney terminations and decorative shrouds.

DM 54 Installation - Terminations

ISO-Cap

The ISO-Cap is a Spark Arrestor/Rain Cap designed to fit atop the Isokern DM 54 Chimney Inner Liner and is available in Stainless Steel, Black Galvanized, Copper, or a Stainless Steel with Damper (Figure 57).

A 14"-diameter sleeve projects from the bottom of the ISO-Cap and inserts into the DM 54 Inner Liner. A two-inch (2") wide flange at the base of the ISO-Cap covers the top surface of the DM 54 Inner Liner to protect the liner from weather.

To Install the ISO-Cap, silicone caulk is used to adhere the two-inch (2") flange to the top of the DM 54 Inner Liner.



FIGURE 57

Decorative Clay Pots

The Elemental Clay Pots are set in a bed of Earthcore Adhesive on the DM 54 Chimney Inner Liner. The base of the chimney top does not need to match the dimensions of the inner liner it is being installed on top of but should not impinge on the inside area of the flue liner except for the maximum of 3/4" in the corners. The flue liner may extend up inside the chimney top, or the flue liner may be flush with the top surface of the chimney cap. Additional anchoring may be used to prevent damage from tornadoes, hurricanes, or earthquakes. A 1/4" to 1/2" diameter hole may be drilled in at least two opposite sides of the chimney top and a bar used to anchor the top into the grout or the chimney walls (Figure 58).



FIGURE 58

NOTE: The Elemental Clay Pots can only be installed on the DM 54 Chimney System. The Clay Pots are not tested and listed for use with Metal Chimney Flue Systems.

Custom Chimney Caps

A non-combustible, weather tight chase flashing must be used to cover the top of the chimney chase. Be sure to seal the joint where the DM liner passes through the chase top flashing for positive weather seal. Chase flashings may be supplied by others. (Figure 59)

Special design caps may be designed and constructed by others and must be fashioned so as not to restrict the flow of smoke and gases out the top of the flue opening. The figure below depicts common chimney terminations.

Check with local building codes to establish the need for chimney caps and spark arrestors or for any limitations to their design and use.

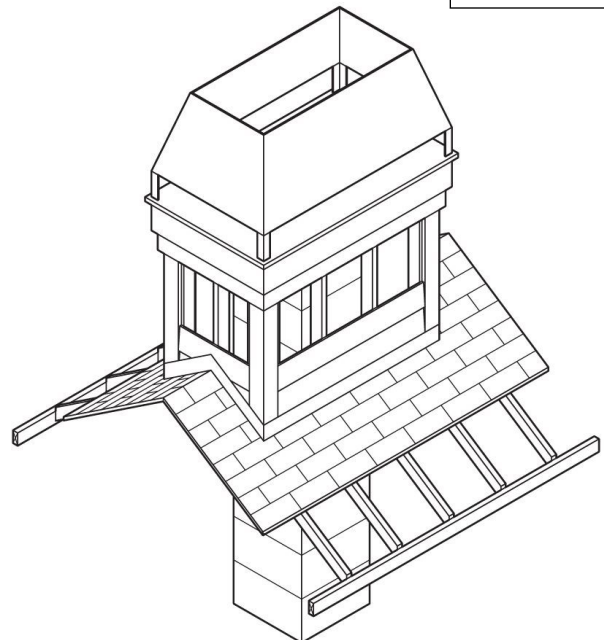

FIGURE 59

ECO-STEEL & ECO-STEEL + Metal Chimney Flue

The MAGNUM 60 & 72 Series Fireplaces are tested and listed for use with Earthcore's Proprietary ECO-STEEL & ECO-STEEL + chimney systems complying with UL103/ ULC-S604.

ECO-STEEL & ECO-STEEL+

A lightweight venting solution created so each section connects securely together. This versatile system has a 12-5/8" inner diameter and 15-5/8" outer diameter and is available in two options.

ECO-STEEL Chimney Features

- Air Cooled
- Double wall, non-insulated
- Locking-tab design
- Stainless-steel inner and galvanized outer pipe:

ECO-STEEL+ Chimney Features

- Insulated
- Double wall with solid-pack insulation
- Locking-tab design
- Stainless-steel inner and outer pipe

NOTE: ECO-STEEL & ECO-STEEL+ are not designed for use on products that operate at continuous temperatures in excess of 1000°F, intermittent temperatures of 1700 °F are acceptable. Only use approved terminations and chimney shrouds provided by Earthcore. Be sure to maintain a 2" clearance to combustibles around the metal chimney flue.

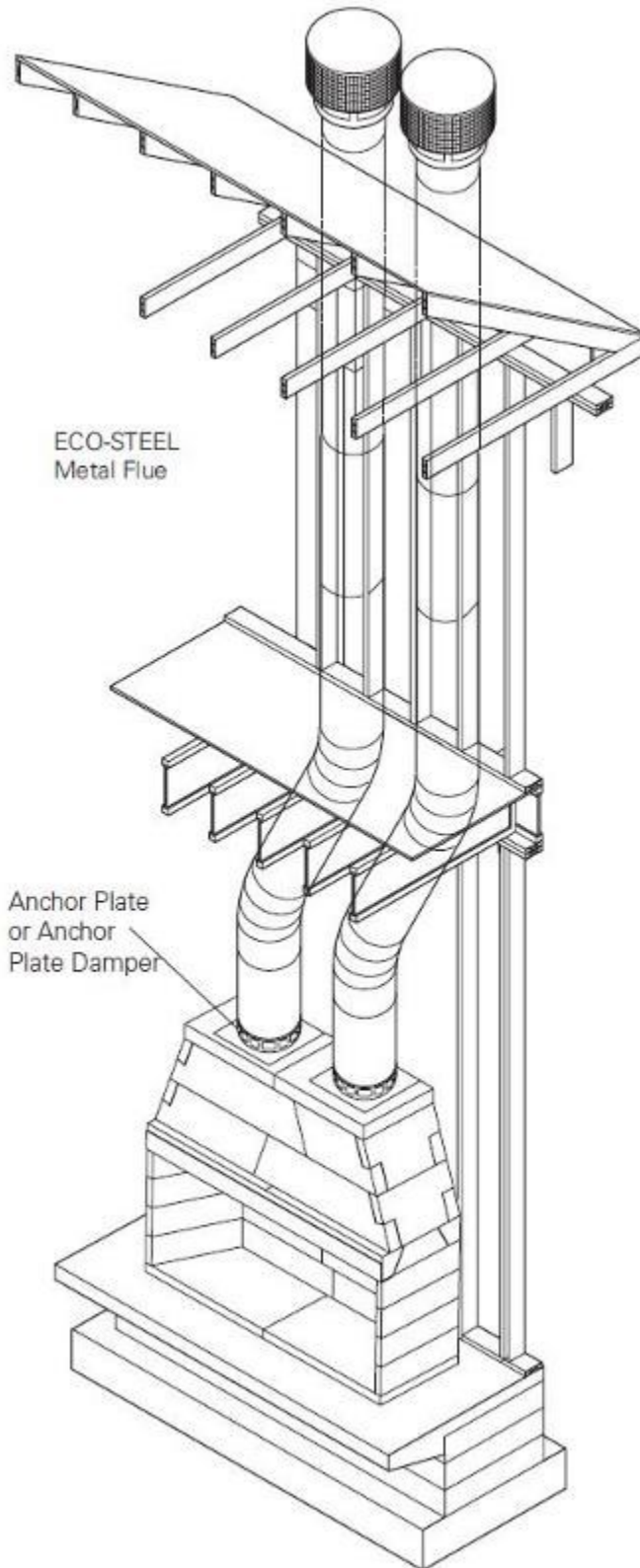

FIGURE 60

Components List - ECO-STEEL Metal Chimney Flue

ECO-STEEL		
Component	Part#	Description
	13ACECO6	6" Chimney Section
	13ACECO12	12" Chimney Section
	13ACECO18	18" Chimney Section
	13ACECO36	36" Chimney Section
	13ACECO48	48" Chimney Section
	13ACECOAP	Anchor Plate
	13ACECOAPD	Anchor Plate w/Damper
	13ACECO15OS	15 Degree Offset
	13ACECO30OS	30 Degree Offset

Components List - ECO-STEEL+ Metal Chimney Flue

ECO-STEEL+		
Component	Part#	Description
	13INECO6	6" Insulated Chimney Section Stainless Steel
	13INECO12	12" Insulated Chimney Section Stainless Steel
	13INECO18	18" Insulated Chimney Section Stainless Steel
	13INECO36	36" Insulated Chimney Section Stainless Steel
	13INECO48	48" Insulated Chimney Section Stainless Steel
	13INECOAP	Insulated Anchor Plate Stainless Steel
	13INECOAPD	Insulated Anchor Plate w/ Damper Stainless Steel
	13INECO15OS	Insulated 15 Degree Offset Stainless Steel
	13INECO30OS	Insulated 30 Degree Offset Stainless Steel

Components List - ECO-STEEL/ ECO-STEEL+ Common Components

ECO-STEEL& ECO-STEEL+ COMMON COMPONENTS		
Component	Part#	Description
	13ACECOFC	Chase Top Flashing
	13ACECOSC	Storm Collar
	13ACECOFS	Firestop
	13ACECOFT	Tall Cone Flashing 1-6/12 and 7-12/12 roof flashing
	13ACECOIS	Attic Insulation Shield
	13ACECOWB	Wall Band
	13ACECOCC	Chimney Cap - Stainless Steel

ECO-STEEL & ECO-STEEL + General Information

The ECO-Steel (Air-Cooled) and ECO-Steel+ (Insulated) Chimney is intended for use on Isokern fireplaces. Do not use with forced draft or positive-pressure appliances. The ECO-Steel and ECO-Steel+ chimney system is designed to extend a maximum of 60 feet vertically. A maximum of 30° offset from vertical is allowed with a total of four 30° elbows (4 elbows) for each chimney installation on naturally drafting fireplaces. Contact Local Building or Fire Officials about restrictions and installation inspection in your area. These instructions must be followed in all detail and failure to do so may result in a hazardous installation.

The following instructions are a general representation for ECO-STEEL & ECO-STEEL+ Chimney Installation:

- The ECO-Steel (Air-Cooled) and ECO-Steel+ (Insulated) Chimney is not designed for use on products that operate at continuous temperatures in excess of 1000°F.
- Creosote and Soot – Formation and Need for Removal: When wood is burned slowly, it produces tar and other organic vapors, which combine with expelled moisture to create creosote. The creosote vapors condense in the relatively cool chimney flue of the slow burning fire. As a result, creosote residue accumulates on the flue lining. When ignited, the creosote makes an extremely hot fire. The chimney should be inspected at least once every two (2) months during the heating season to determine if a creosote or soot buildup has occurred. If creosote or soot has accumulated, it should be removed to reduce the risk of chimney fire.
- Chimneys must be installed so that access is provided for inspection and cleaning.
- Never fill any required clearance space with insulation or any other building materials surrounding the chimney.
- Do not use a fireplace for food grilling. Grease from foods can collect in chimney causing fireplace to become a potential fire hazard.
- Some chemical chimney cleaners can be harmful to the chimney. These cause accelerated oxidation or corrosion. If chemical cleaners are used, they must be non-corrosive in nature. If a brush is used, it must be of proper size with plastic bristles. Have your chimney cleaned by a professional, certified chimney sweep.
- If a flue fire occurs, close all possible air inlets, and call your Fire Department. Do not use the chimney again until it has been inspected by a Certified Chimney Sweep for possible damage.
- Exterior metal parts, with exception of the top portion of the chimney cap, can be painted with a high temperature rust proof paint. Wash the metal surface with a vinegar and water solution to remove any residue before painting. Painting the chimney will help to increase chimney life.
- Earthcore assumes no liability for structural damage or roof contamination as the result of creosote formation. It is the owner's responsibility to comply with inspection and cleaning requirements as described in these instructions, and those of the appliance manufacturer.
- Interior chimneys shall be enclosed where they extend through closets, storage areas, occupied spaces, or anywhere the surface of the chimney could be contacted by persons or combustible materials. **The air space between the outer wall of the chimney and the enclosure shall not be less than 2 inches.**

WARNING: Do not place any type of insulation or other materials in the required clearance spaces surrounding the chimney assembly.

- Except for installation in one- or two-family dwellings, a factory-built chimney that extends through any zone above that on which the connected appliance is located is to be provided with an enclosure having a fire resistance rating equal to or greater than that of the floor or roof assemblies through which it passes.
- In cold climates, chimneys mounted on an outside wall should be enclosed in a chase. Exterior chases reduce condensation, creosote formation, and enhance draft.
- Proper planning for your ECO-Steel (Air-Cooled) and ECO-Steel+ (Insulated) Chimney installation will result in greater safety, efficiency and convenience. You must use only ECO-STEEL & ECO-STEEL + Chimney parts and components to maintain a listed chimney system. Do not mix parts or try to match with other products or use improvised solutions.
- Install your Isokern fireplace as described in this installation manual and maintain all required clearances.
- Connect only one fireplace per chimney. Follow the fireplace safety manual for maximum efficiency and safety.
- Do not over fire. Any damage to the fireplace or chimney can possibly void the warranty.
- Do not burn driftwood, plastic, or chemically treated wood such as railroad ties. They are corrosive to your chimney system.

NOTE: For ECO-STEEL & ECO-STEEL + installation, see pages 45-49 or visit website earthcore.com to download pdf.

A MAJOR CAUSE OF CHIMNEY RELATED FIRES IS FAILURE TO MAINTAIN REQUIRED CLEARANCE (AIR SPACES) TO COMBUSTIBLE MATERIAL*. MINIMUM CLEARANCE FOR 13" DIAMETER AIR-COOLED AND INSULATED CHIMNEY IS TWO (2) INCHES. IT IS OF UTMOST IMPORTANCE THAT THIS CHIMNEY IS INSTALLED ONLY IN ACCORDANCE WITH THESE INSTRUCTIONS.

ECO-STEEL & ECO-STEEL+ Metal Chimney Installation

1. **Mount Anchor Plate:** Chimneys for Isokern fireplaces begin with an Anchor Plate or Anchor Plate with Damper. It is important that the surface of the Isokern chimney has a level surface on which to attach the Anchor Plate. If the top of the Isokern does not have a level surface, it will need to be modified accordingly.

Center the Isowool blanket over Isokern Top Plate hole and trace outline of hole with a pen or marker. Cut a hole in the blanket to match the hole in the Isokern top plate. Center the Iso-wool blanket over the Isokern Top Plate flue opening, then center anchor plate over the Iso-wool blanket. If a damper is used, make sure nothing interferes with the damper plate movement.

Secure the Anchor Plate with minimum of four (4) masonry anchors. **(Figure 61)** If the Anchor Plate with Damper is installed the damper should swing freely. When the chain is pulled down, the damper should close (horizontal position). When the chain is released (no weight on the chain), the damper should swing open (vertical position). To install the lintel hook, place the damper plate in the closed (horizontal) position. Determine and mark the position of the lintel hook. The lintel hook should be mounted in a position that provides a small amount of tension in the spring attached to the chain. The tension is needed to prevent the damper plate from rattling when closed. Mount the lintel hook to masonry with the screws provided. Do not obstruct oval openings in the anchor plate.

WARNING: Do not locate Anchor Plate with Damper in a location inaccessible for inspection, cleaning and servicing after installation.

2. **Attach Chimney:** Attach the first section of chimney on the Anchor Plate. The joint assembly is a male to female slip-fit and held together with tab lock, twist lock, or screwed together. **(Figure 62)**

If installing screws, do not penetrate the inner liner of the chimney with screws. Maintain a 2-inch (2") clearance to combustibles. Do not fill the clearance space with any materials. If an offset is required, refer to Elbow Offset Installation Section.

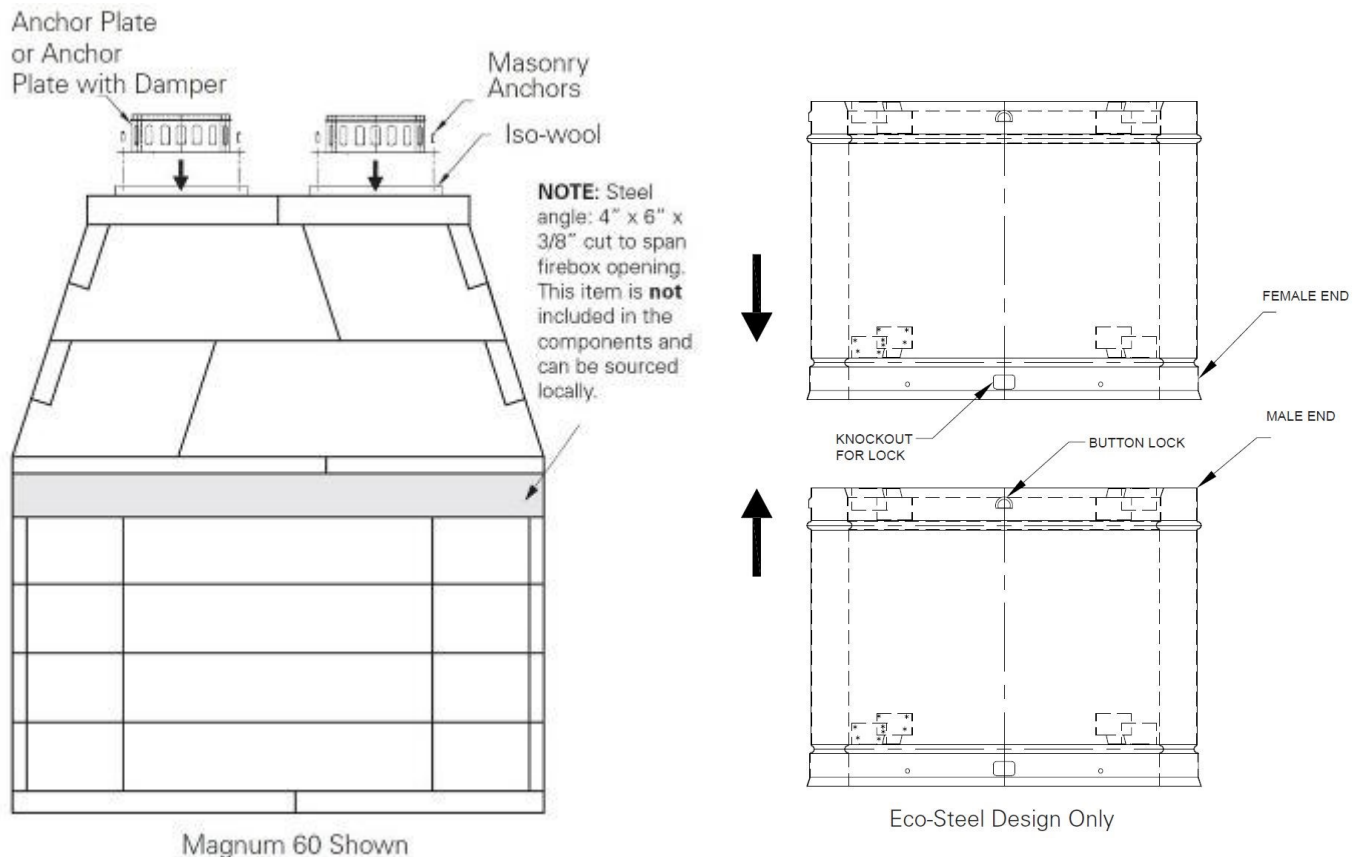
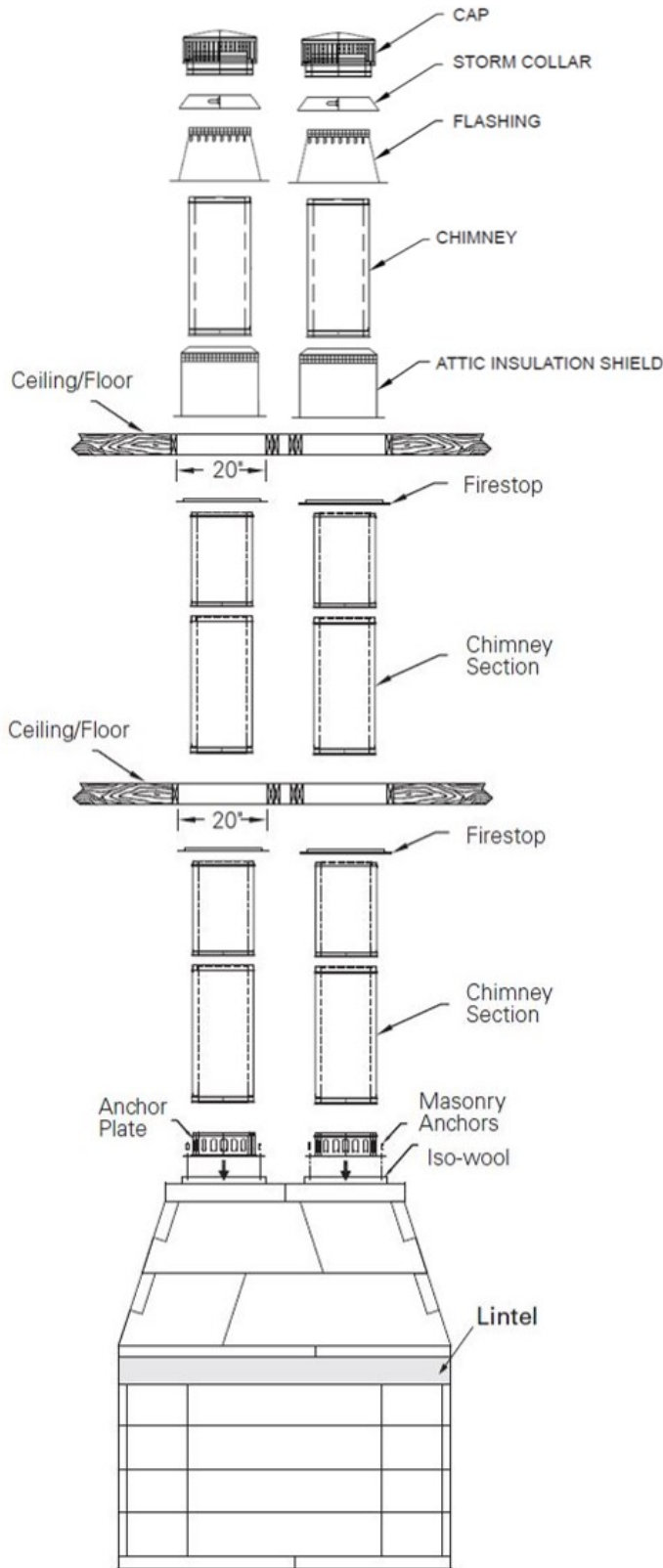

FIGURE 61

FIGURE 62

ECO-STEEL & ECO-STEEL+ Metal Chimney Installation



3. **Frame Openings:** From the ceiling, drop a plumb bob to the center of the fireplace's flue outlet and mark the center point on the ceiling. See **TABLE 1** below.

Frame Opening Dimensions	
Diameter	Framing Dimensions
16" O.D. nominal	20" X 20"

TABLE 1

Mark appropriate cutting lines around the center point. Cut a square hole in the ceiling. Frame a level, square opening centered over the hole that you have cut.

Frame openings at each floor level above the fireplace. (**Figure 63**) These openings are to hold the Firestop and Attic Insulation Shield. Locate each opening by dropping a plumb bob to the four corners of the opening below. Maintain the 2-inch airspace to combustibles. (**Figure 64**)

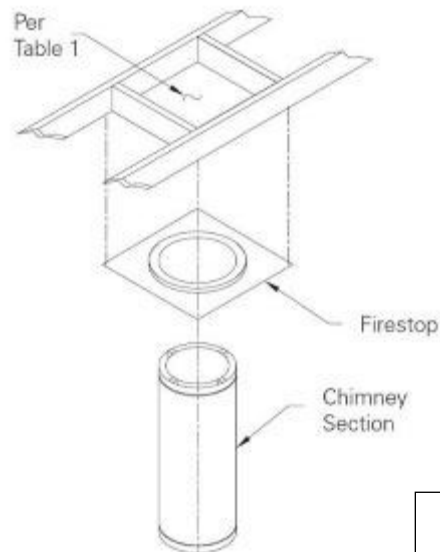

FIGURE 64

4. **Cut Roof Opening:** If penetrating through the roof, determine and cut an opening in the roof directly above the opening below. The cut opening must be 4 inches larger than the chimney's outside diameter to provide at least a 2 inch clearance all around the chimney. The chimney must be centered in this opening.
5. **Install Firestop:** A Firestop is required on each floor penetration in multistory installations. Building Codes require a Firestop at every floor/ceiling level including where the chimney penetrates the attic. **Figure 63** shows a typical 2 story installation with an attic.

NOTE: A Firestop is not installed where the chimney penetrates through the roof. The Firestop is installed on the underside of the ceiling/floor framing and secure in place with nails or screws. (**Figure 63**)

FIGURE 63

ECO-STEEL & ECO-STEEL+ Metal Chimney Installation

6. Angle Support and Support Band: Install an Angle Support if total chimney height is greater than 50 feet, or if the fireplace manufacturer requires it. If additional support is needed, install one or more Angle Supports which will support an additional 30 feet of chimney. **(Figure 65)**

Slide the Angle Support around the chimney and align over framed opening. Secure to casing with four (4) sheet metal screws and assemble brackets. **(Figure 66)** Nail the brackets to the framing using a minimum of two (2) nails or screws per bracket.

A Support Band may be required by some fireplace manufacturers to keep the chimney vertical and help maintain clearances to combustibles within a chase. Clamp the Support Band to the pipe using the nut and bolt provided and secure legs to nearby framing using plumbers strap or guy wires. **(Figure 67)** The Support Band does not support the weight of the chimney; it is only used to keep the chimney centered within a chase.

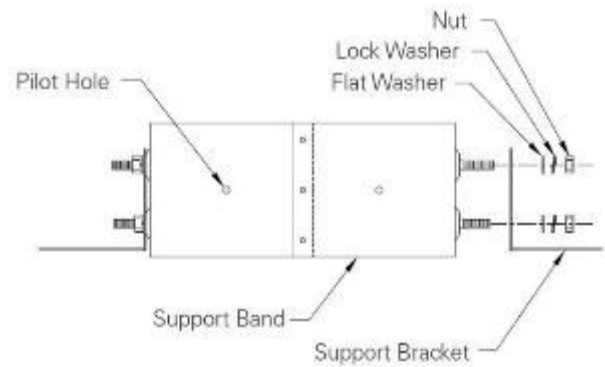
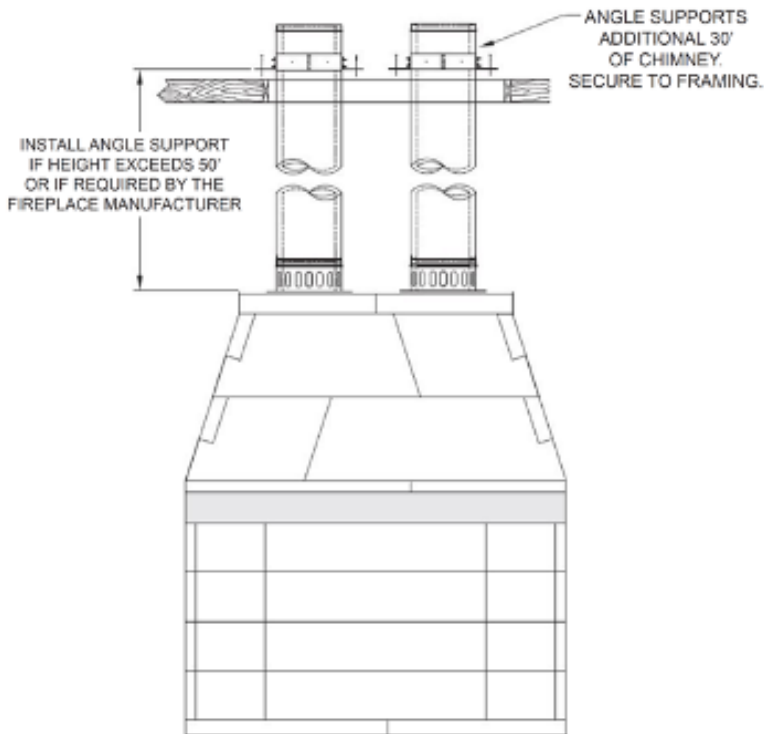

FIGURE 65

FIGURE 66

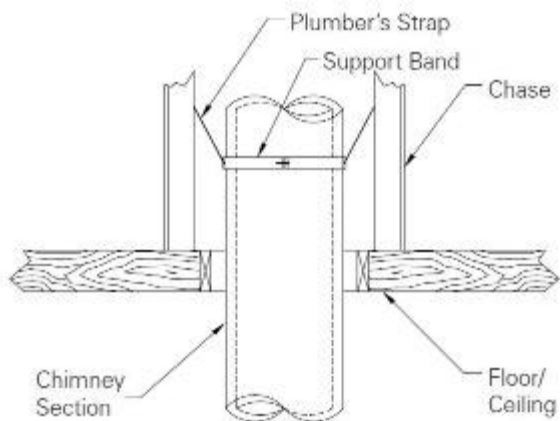

FIGURE 67

ECO-STEEL & ECO-STEEL+ Metal Chimney Installation

7. **Attic Insulation Shield:** The Attic Insulation Shield must be installed where the chimney passes into an attic. Its purpose is to maintain clearances from loose packed or blown insulation from the chimney. If an Attic Shield is not used the chimney needs to be enclosed within a framed enclosure. Always maintain a 2" air-space clearance to combustibles. Install the shield as follows:

- Remove any insulation or debris from attic floor around the framed opening.
- Assemble chimney sections above the Firestop to a height that extends beyond the height of the attic insulation shield.
- Slip the Attic Insulation Shield over the chimney until the base sits squarely on the framed opening.
- Secure the Attic Insulation Shield to the top of the framed opening using nails or screws (**Figure 68**).

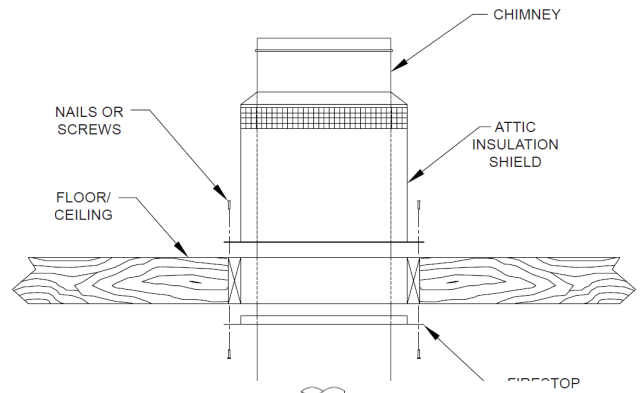

FIGURE 68

8. **Elbow Installation:** 15° and 30° elbows are provided to allow chimneys to avoid framing members or roof peaks. A maximum of 30° from vertical is allowed and a total of four 30° elbows (4 elbows) for each chimney installation on naturally drafting fireplaces. If more than two offsets (4 elbows) are needed, a mechanical exhaust fan shall be used. The mechanical fan company would determine the viability of performance. A 2" clearance to combustibles must be maintained.

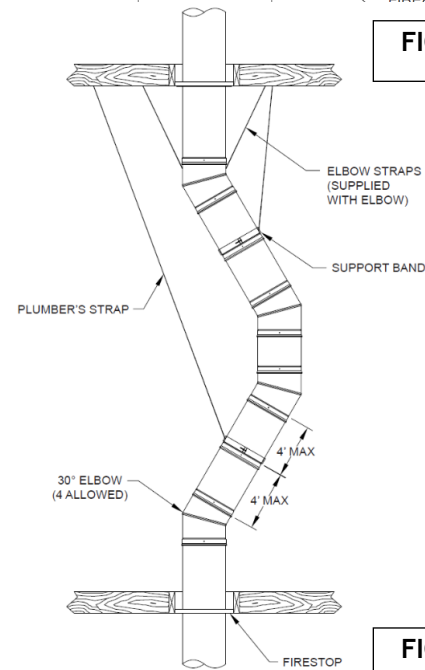

FIGURE 69

Attach the elbow to the chimney pipe, support or other part.

Using the offset chart, add chimney sections between elbows. **A Support Band or plumbers strap is required for every 4-foot interval between elbows to support the load. (Figure 69)** Attach the upper elbow to bring the chimney back to vertical.

See **TABLE 2** and (**Figure 69**) for offset combinations. A maximum of 2 offsets (4 elbows) are allowed per each flue.

OFFSET COMBINATIONS:

If adding one or more straight lengths to the offsets shown in TABLE 2, use the dimensions below and add to "B" (rise) and "C" (run) for overall offset dimensions.

30° ELBOWS

- 6" length, add 4.060 to "B" (rise) and 2.344 to "C" (run).
- 12" length, add 9.256 to "B" (rise) and 5.344 to "C" (run).
- 8" length, add 14.452 to "B" (rise) and 8.344 to "C" (run).
- 36" length, add 30.041 to "B" (rise) and 17.344 to "C" (run).
- 8" length, add 40.433 to "B" (rise) and 23.344 to "C" (run).

15° ELBOWS

- 6" length, add 4.528 to "B" (rise) and 1.213 to "C" (run).
- 12" length, add 10.324 to "B" (rise) and 2.766 to "C" (run).
- 18" length, add 16.119 to "B" (rise) and 4.319 to "C" (run).
- 36" length, add 33.506 to "B" (rise) and 8.978 to "C" (run).
- 48" length, add 45.097 to "B" (rise) and 12.084 to "C" (run).

Example: If needing to add an additional 6" length to the 18" length ("A") from the 15° angle table, the new "B" dimension will be 38.875 + 4.528 = 43.403 (rise). The new "C" dimension will be 7.000 + 1.213 = 8.213 (run).

TABLE 2. OFFSET COMBINATIONS

ECOSTEEL & ECOSTEEL+ OFFSET TABLE				
A	15° Angle		30° Angle	
LENGTH	B	C	B	C
0	23-1/8"	2-7/8"	22"	5-1/2"
6"	27-1/4"	4"	25-3/4"	7-5/8"
12"	33"	5-1/2"	31"	10-5/8"
18"	38-7/8"	7"	36"	13-5/8"
36"	56-1/4"	11-3/4"	51-3/4"	22-5/8"
48"	67-7/8"	14-7/8"	62"	29-1/2"

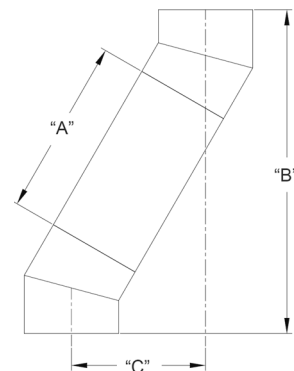

ECO-STEEL & ECO-STEEL+ Metal Chimney Installation

9. For chase enclosures, install the chase top cover (supplied by others) to the chase enclosure. Cut a hole in the chase top cover the same diameter as the base of the cone on the flashing. Attach the Flashing to the top of the chase cover, sealing with a non-hardening waterproof sealant. Secure in place with screws or rivets. **(Figure 70)**
10. Attach the storm collar around the chimney above the screen of the flashing. Secure in place with the locking tab and button. Seal around the storm collar with a non-hardening waterproof sealant. Attach the Termination Cap to the chimney by sliding the male to female joint connection together and secure in place with four (4) sheet metal screws provided. **(Figure 71)**
11. **Termination:** NFPA 211, "Standard for Chimneys, Fireplaces, Vents, and Solid Fuel-Burning Appliances", states that chimneys shall extend at least three feet above the highest point where it passes through the roof of a building, and at least two feet higher than any portion of a building within ten feet. **(Figure 72)**

If the horizontal distance from the chimney edge to the peak of the roof is greater than 10', a chimney height reference point is established on the roof surface 10' horizontally from the chimney edge. The top of the chimney (point where exhaust gases exit) must be at least 2' above this reference point. In all cases the chimney must terminate a minimum of 3' above the highest point of the roof opening.

The ten-foot rule is necessary in the interest of safety and does not ensure smoke free operation. Trees, building, adjoining rooflines, adverse wind conditions, etc., may require a taller chimney should a smoking problem exist.

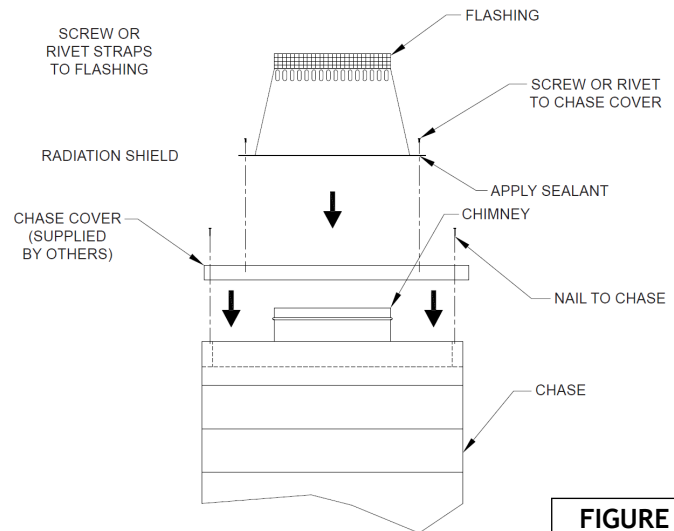

FIGURE 70

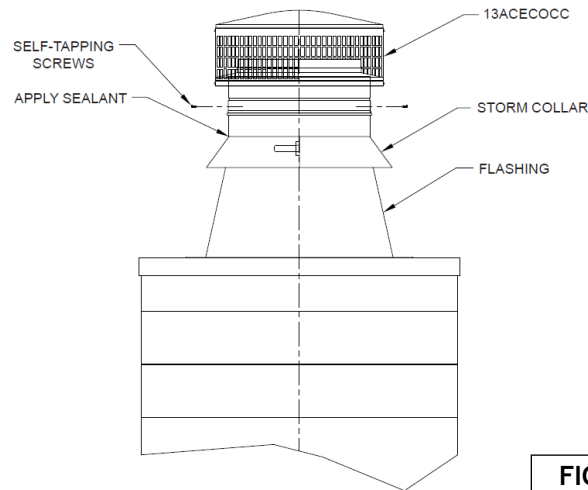

FIGURE 71

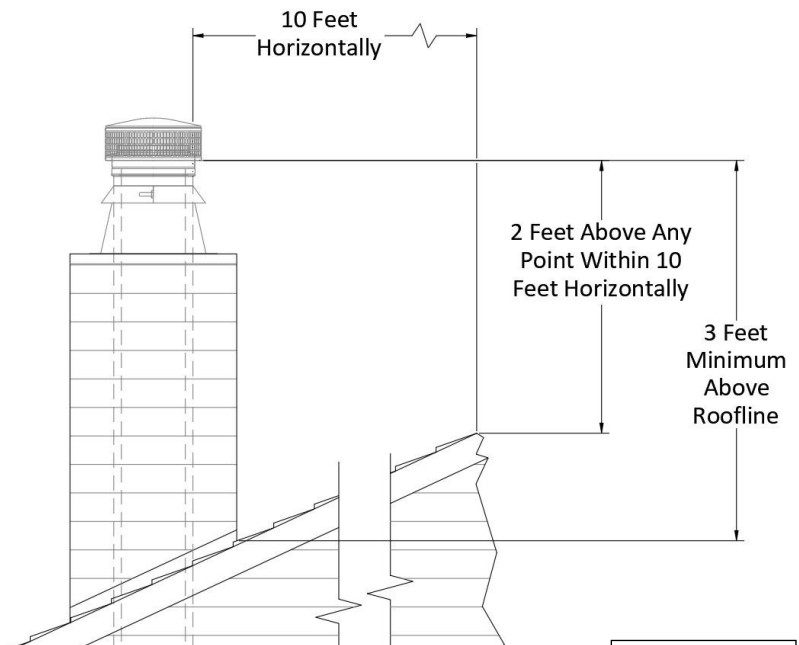

FIGURE 72

Guide for Mechanical Draft System

The X-VENTISO WBC-DUO wood-burning control system is designed to work in conjunction with XVENTISO fan and adapters in dual-flue solid-fuel applications. The system is made up of several components that are factory preset for most solid fuel fireplaces and uses 100% Molex® “plug and play” quick connections for easy installation. Only a single 120 VAC receptacle must be installed within reach of the XV-WBC-DUO 6ft power cord to provide power to the entire system.

The X-VENTISO WBC-DUO control box has been designed to enable fan operation while continuously monitoring and maintaining draft to safely exhaust flue products from dual-flue solid-fuel fired fireplaces. This control box must be installed in an accessible location in framing (refer to install manual) and uses the X-VENTISO Wall Control as the user interface of the system. The wall control is a wall mounted device that is an intelligent, easy to install, constant speed controller for the system. It features a sliding control with LED’s that provide visual monitoring of system status and alarms, and meets all code requirements for NFPA211.

The X-VENTISO WBC-DUO Wood Burning Control is sealed from the factory and should require no adjustment of any user parameters. In the event that an alarm occurs and fails to clear, or the fireplace is not operating properly, contact us at (817)-393-4029.

DO NOT ATTEMPT TO OPEN THE UNIT AND ALTER ANY SETTINGS. THIS WILL VOID THE WARRANTY.

The XV-WBC-DUO installation utilizes:

- Isokern dual flue fireplace
- Dual Class-A flue
- XV-Series Fan Adapter
- XV-Series Fan
- XV-WBC-DUO Wood-Burning Control System
 - ◊ WBC-DUO Controller
 - ◊ Adjustable Speed Wall Control with Audio and Visual Alarm Status
 - ◊ Optional Light Switch

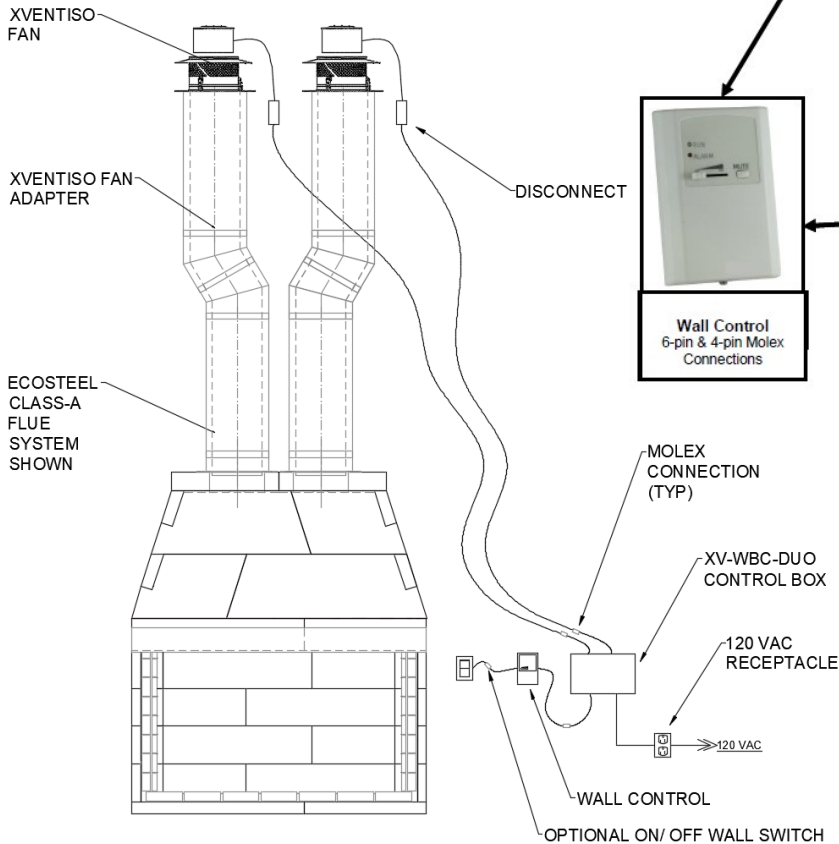

XV-WBC-DUO Component Layout

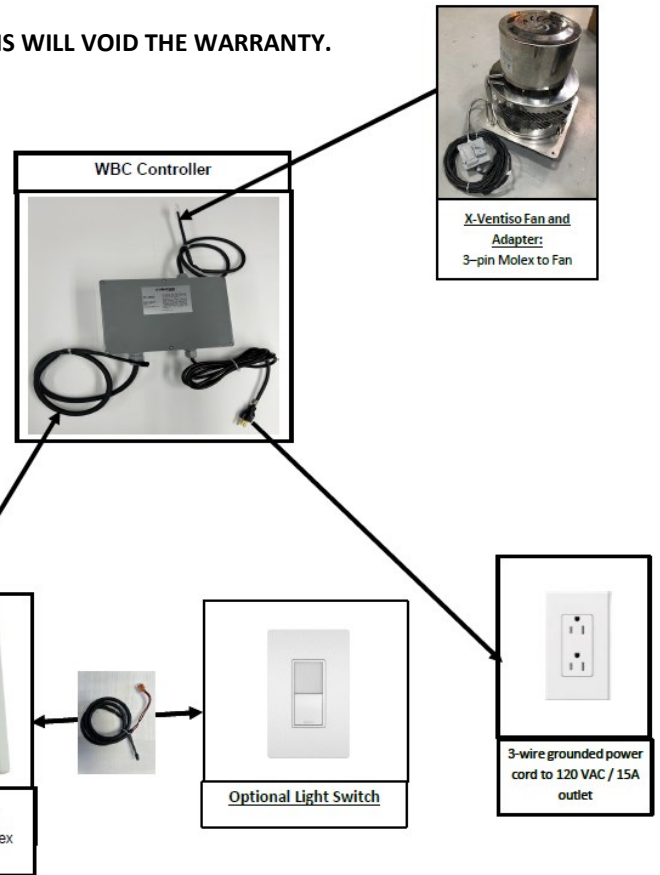

Typical XV-WBC-Component Layout
(DUO version has two fan outputs)

Access Modification - Combustion Air Kits, Gas & Electrical Line Feed

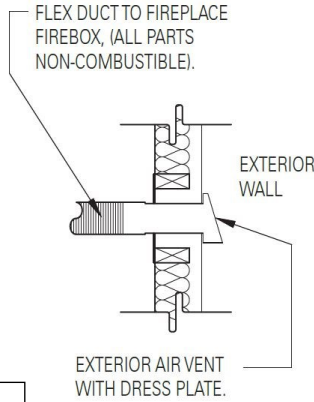

FIGURE 73

Two four-inch (4") supplemental combustion air inlet kits may help improve fireplace operation in homes tightly sealed and with other ventilating appliances installed (**Figures 73 & 74**). The following is a general representation of a combustion air kit.

The air kit is fitted into the front 1/3 of the side wall of the firebox by core drilling an appropriately sized hole at the selected firebox location. Keep the top of the access hole no more than six inches (6") above the finished firebrick floor. The hole size should allow for a quarter inch (1/4") joint around the air access sleeve for heat expansion and must be sealed properly. Do not install in the rear of the firebox.

Combustion air-kits must be installed in accordance with local codes.

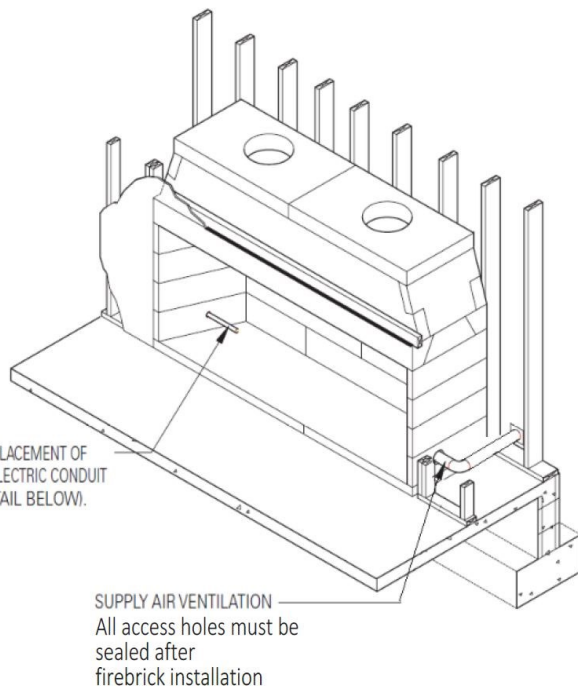

FIGURE 74

Fireplace Make Up Air Requirements	
Magnum 60/72 Series	
Model #	Consumption Air Flow (CFM)
82060	730
82072	876

WARNING: Do not use combustible duct material. Avoid installing a combustion air inlet where the opening could be blocked by snow, bushes, or other obstacles. Air inlet ducts shall not terminate in attic, basement, or garage spaces.

Gas Line Feed

For a fireplace having the provision for installation of a gas pipe, the provision is intended only for connection to a decorative gas appliance.

CAUTION: When using the decorative appliance, the fireplace damper must be locked in the fully open position. Gas line for gas log sets used in the Isokern firebox can be routed through the side wall, by drilling an appropriately sized hole using a masonry drill bit. (**Figure 75**)

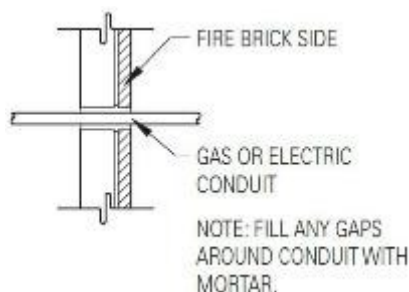

FIGURE 75

Electrical Line Feed

Can be routed through the firebox side walls by drilling an appropriately sized hole using a masonry drill bit. Be sure to follow the gas log appliance manufacturer's explicit electrical line connection instructions for vented masonry fireplace installations. Gas line and electric line must be fed through separate access holes.

CAUTION: All access holes must be grouted with mortar – after line or conduit feed - to seal any gaps or cracks around line feed conduits. (**Figure 73,74, & 75**)

Firebrick Installation

The manufacturer requires the MAGNUM 60" & 72" model fireboxes be lined with a minimum 1-1/8" thick firebrick for the Floor and Backwall (2-1/2" for Fire-lite+ application), and four-inch (4") firebrick on the sidewalls. Thicker firebrick may be used as an option. The pattern for the firebrick lining is an owner option. The ISOSET mortar by Earthcore is to be used when lining the Isokern Fireplace.

The ISOSET Firebrick Mortar Application:

- Add .75 quarts of water per 10lbs of dry product until completely blended.
- Only mix what can be utilized within 15 minutes
- Do not retemper (retempering is the addition of water after the chemical reaction has begun).
- The use of warm water will accelerate setup
- Joint thickness should be thin (1/4" - 3/8")
- Complete set time is between 48 & 72 hours.
- For best results, please allow 28 days before heat is applied.
- Approximately 35 to 40 lbs. of prepared mortar will lay up one hundred 9 x 4½ x 2½" Straights.
- **DO NOT add additives such as fireclay, sand, cement, or other accelerators.**

NOTE: These instructions may vary because of different climates and conditions. The use of good masonry practices for your area should also be considered.

Installation Instructions:

1. Wet mop the inside of the fireplace with a damp sponge to remove dust and loose particles from the interior before installing firebrick. Keep the fireplace damp while installing firebrick.

For Best Results:

- After wet-sponging interior of firebox, apply a 1/4 notch bed joint on rear sides and floor.
 - Dip each firebrick in a pale of water before applying mortar to one side for adherence to firebox.
2. Face joint dimensions of 1/4" to 3/8" in the brick work are recommended and have the best appearance. Other face joint dimensions are acceptable, however smaller joints may not leave room for heat expansion of firebrick.
 3. Start the firebrick at the front edge of the floor of the Isokern firebox, proceeding inward toward the back. Leave a ½" expansion gap between the firebrick and the side and back walls. This air space allows heat expansion of the firebrick and is to be left empty of mortar. (Figure 76)
 4. Next, apply firebrick to the back wall of the unit. The back wall firebrick covers the 1/2" expansion gap left at the brick floor along the back wall of the firebox. Leave a ½" expansion gap at the sides and top (Figure 77).
 5. Set the side wall firebrick by starting at the front edge of the unit's side wall and working inward toward the back wall firebrick. The side wall firebrick, when completed, covers the 1/2" expansion gaps where both the floor firebrick and the back wall firebrick were held off the unit's side walls. (Figure 78). Leave 1/2" expansion gap at top.

All required through-wall accesses (gas and air intake supply access holes) should be drilled before the required firebrick lining is installed. Do not cover these areas with firebrick.

Earthcore makes no claims as to the performance of firebrick or firebrick mortar(s). It is typical for heat stress cracks to appear in the firebrick in fireplaces.

The expansion joint in this illustration is on the hearth.

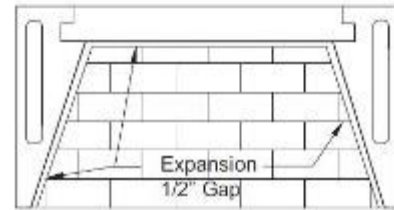
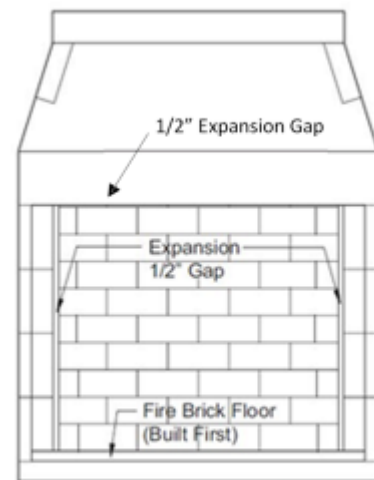

FIGURE 76



The expansion joint in this illustration is on the backwall.

FIGURE 77

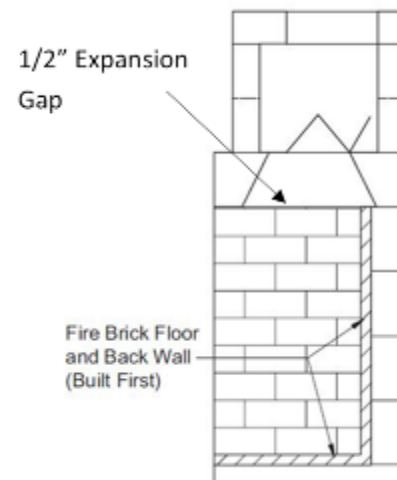

FIGURE 78

Flush Wall Finish Detail

When drywall is the wall finish at the MAGNUM 60 &72 face and flush with the rough face of the firebox and damper beam, it is recommended when installing the required firebrick lining to the interior of the firebox, that the leading edge of the firebrick - at the floor and at the side walls of the firebox - be set flush with the rough firebox front. This will aid in the overall fit and finish of the MAGNUM 60 &72 Series fireplace front when the code required non-combustible finished facings are applied.

This alignment of firebrick application, as shown below (**Figure 79**), allows the firebrick lining to be in the same plane with the room's wall finish surface. With the firebrick set in this fashion the non-combustible finish facing material can be set tight against the leading edge (or, "room edge") of the firebrick at the sides of the fireplace opening. At the same time the finished facing material can lay flat against the room's finished wall surface.

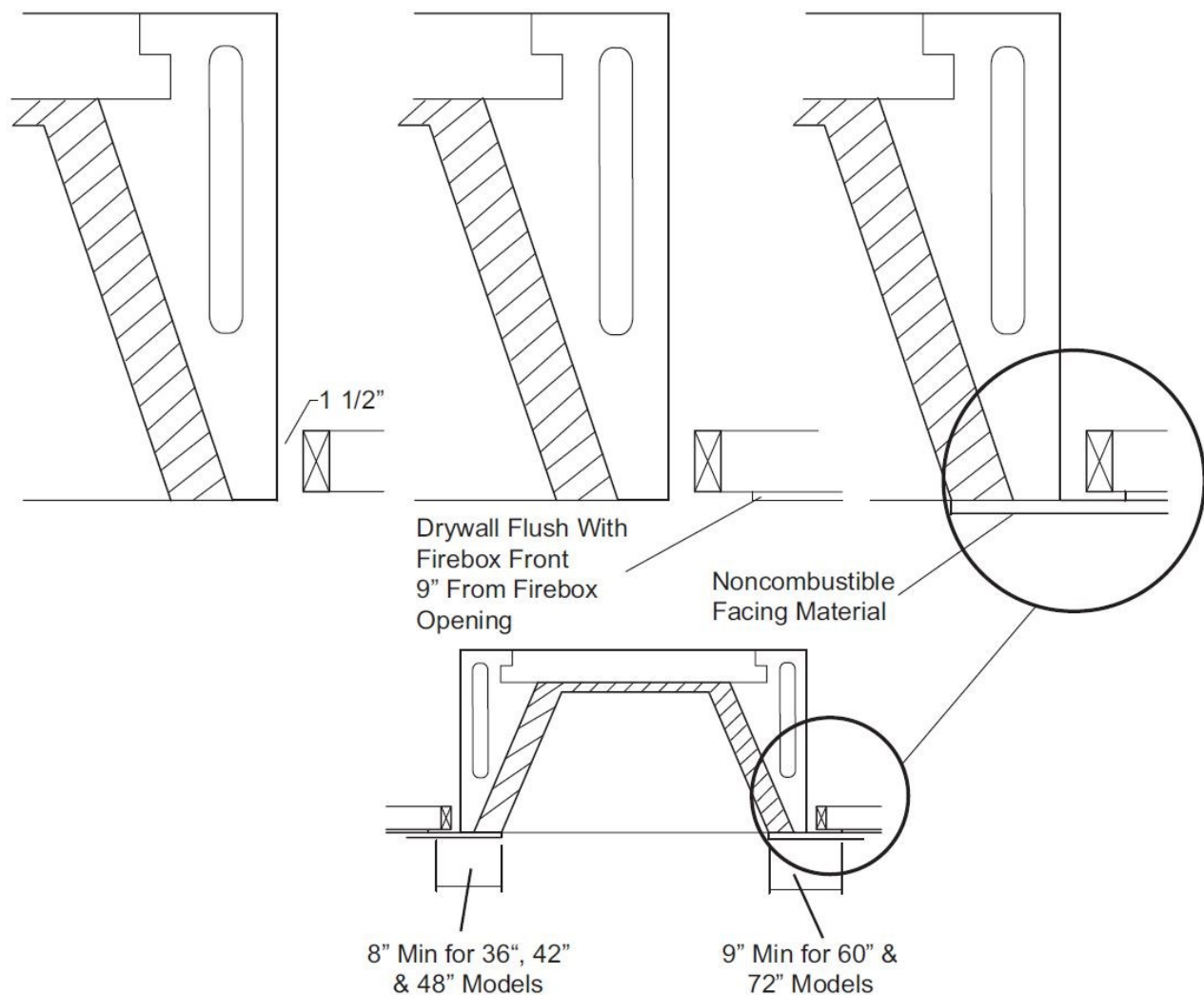

FIGURE 79

Clearance to Combustible Trim- 60 & 72 Models

Hearth Extensions

All MAGNUM 60 & 72 fireplaces shall have hearth extensions of brick, concrete, stone, tile, or other code approved non-combustible material. Suitable hearth extension material for the MAGNUM 60 & 72 Series fireplace shall be placed on the hearth extension's non-combustible substrate and must extend to at least thirty inches (30") in front of the fireplace's finished opening and must extend to at least twelve inches (12") beyond the sides of the finished fireplace opening. **(Figure 80 & 81).**

WARNING: The non-combustible hearth extension, by code, must sit on non-combustible substrate which shall have no wood underpinnings.

This means that off-grade wood floor systems shall be constructed in such a way that all wood floor joists and sub-flooring shall stop thirty inches (30") out from the front of the MAGNUM 60 & 72 firebox. **(Figure 81)**

Mantel and Mantel Shelf Clearances

MAGNUM 60 & 72 Series fireplaces are subject to the same building code safety clearances to combustible trim as with any radiant heat fireplace. All combustible trim shall be kept at least nine inches (9") from the finished fireplace opening sides and twenty-four inches (24") of the finished opening top. Combustible trim located along the sides of the fireplace opening, which project more than one and one-half inches (1-1/2") from the face of the fireplace, shall have additional clearance from the nine inches (9") equal to the projection. Combustible mantels up to twelve inches (12") of projection - shall not be placed less than twenty-four (24") from the top of the fireplace opening. Combustible mantels which project more than twelve inches (12") from the face of the fireplace, shall have additional clearance from the twenty-four inches (24") equal to the projection.

NOTE: The local authority having jurisdiction may require greater clearances for projection combustible mantel shelves. Be sure to check local building codes regarding required clearances to projecting combustible Mantels.

Adjoining Walls

Side walls and walls to rooms adjoining the MAGNUM 60 & 72 Series fireplace installations cannot be closer than forty-eight inches (48") to the finished fireplace opening. **(Figure 81)**

NOTE: "Clearance to Combustible Trim" are those distances required to ensure that a fireplace mantel or facing will not catch fire. In most cases the distances should also be adequate to prevent any discoloration or warping due to heat. However, each installation presents a unique and completely different set of circumstances involving many variables. These include paint or finish composition, previous exposure to heat, methods and quality of construction, air flow patterns, etc. Because of these variables the manufacturer does not guarantee that heat warping, or discoloration will never occur.

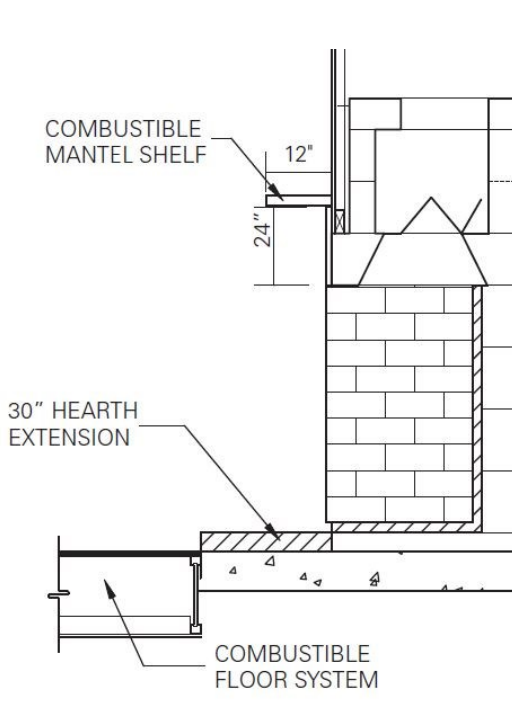

FIGURE 80

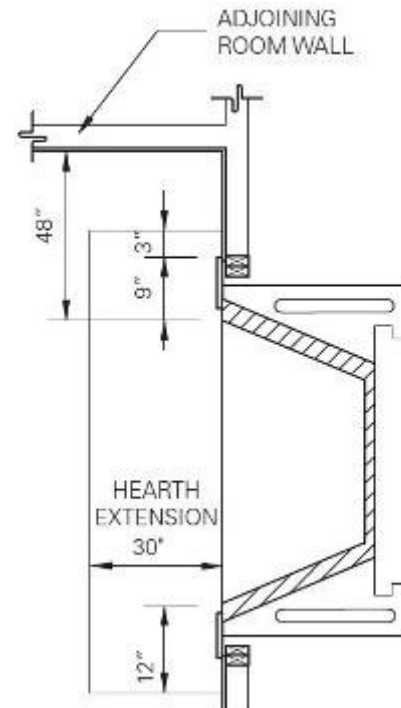

FIGURE 81

Specialty Applications – Outdoor Installation

The Isokern fireplace can be used in an outdoor application and is considered an "Outdoor Application" if the fireplace is a freestanding unit, located a minimum of ten feet (10') away from any structure. These structures would include your house, patio cover, detached garage or any other standing structure. **(Figure 82)**

Selecting an Outdoor Location

To determine the safest and most efficient location for the fireplace, you must take into consideration the following guidelines:

1. The location must allow for proper clearances and venting.
2. Consider a location where the fireplace will not be affected by down drafts, impending structures, or frequently opened doors.
3. Avoid a location where the chimney termination will be near abrupt changes in the roof shape, nearby walls, under trees or above the roof of a single story wing of a two story building.

Chimney Flue

Recommended minimum height of chimney as measured from base plate of the fireplace to flue gas outlet of termination should be 9½ feet and must be a minimum of 10 ft from any structure. If the fireplace is located adjacent to structures on the property, the chimney height should be a minimum of two feet taller than that structure. The height of the chimney will require calculated dimensions to make sure the smoke vents properly upward through the chimney and doesn't create a downdraft that will push the smoke back out of the hearth.

The use of either the DM 54 or ECO-STEEL & ECO-STEEL + Chimney flue are the recommended flue types for the MAGNUM 60 & 72 models in the outdoor application. If the use of ECO-STEEL & ECO-STEEL + Chimney is used a 2" clearance to combustible material is required. See pages 40-49 for more information.

Supporting Footers

In the outdoor application careful load calculations should be made for the veneer type used on the fireplace as well as the chimney weight.

Foundations and footings must be made of a frost-protected foundation and be approved by the local building authority. For any foundation design and load requirements check with the local structural engineer. **It is the responsibility of the General Contractor to ensure adequate foundations.** See page 14 for fireplace weights and "footprint" areas.

IMPORTANT: Due to heat and weight issues, the Isokern fireplace and DM 54 chimney system installations require that the system be built upon a non-combustible concrete slab with no wood underpinnings supported to footings with concrete or steel and designed to carry the total weight of the Isokern fireplace and chimney system.

Assembly Instructions

Refer to the assembly instructions that are found on pages 18 - 28.

NOTE: A damper is not required in an outdoor application of the Isokern Fireplace.

Clearance to Combustibles

The Required Clearances to Combustibles as detailed on pages 12, 13, 53, and 54 shall apply to all outdoor installations.

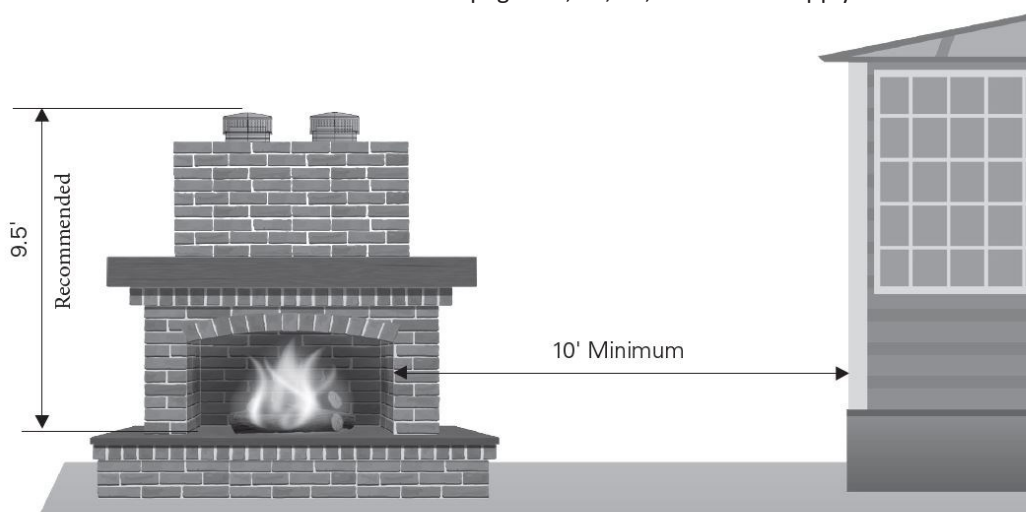

FIGURE 82

Specialty Applications – Reduced Height Fireplace Opening

The Isokern Fireplace can have a reduced height opening by removing one layer of backwall and sidewalls from the fireplace construction. All other construction for the fireplace will remain the same as shown on pages 18-28. The use of two flues on the 60" & 72" models will still be required.

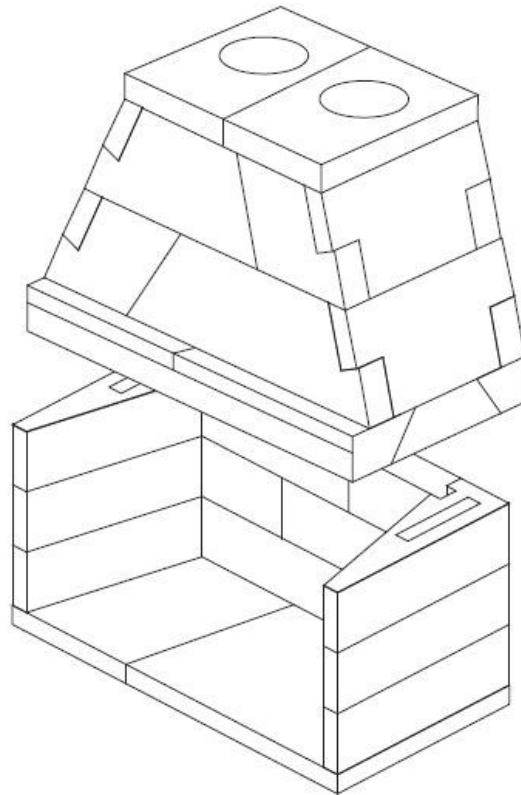

FIGURE 83

Specialty Applications – Recessed Fire-Lite + Application

If the design preference is for a flush hearth installation of the Fire-Lite+ application (floor of the fireplace at the same level the room's floor), the Fire-Lite+ Kit can be lowered and attached to the joist system with advanced planning.

When calculating depth of recess required for a flush hearth, be sure to account for the 13" assembled thickness of the Fire-Lite+ application

IMPORTANT: Whether a flush hearth is preferred or a raised hearth, the Fire-Lite+ application requires that the combustible floor in front of the fireplace must be covered with a non-combustible hearth extension set tight against the fireplace front and extend at least 30" out from the finished fireplace and at least 12" beyond the finished sides of the fireplace opening.

NOTE: Field verified dimensions should make allowance for hearth extensions in front (30") and sides (12" ea.) from the fireplace opening. Also, make sure fireplace sides and rear have minimum 1-½" clearance to combustibles.

IMPORTANT: The level of the finished firebrick hearth floor and noncombustible hearth extension shall not be recessed below the level of the finished floor.

NOTE: For seismic anchorage design and instructions of the flush hearth application, please contact the Technical Department 1-800-642-2920.

Specialty Applications – Recessed Fire-Lite + Application

Recessed applications of the MAGNUM 60 & 72 Fire-Lite+ application should be constructed in accordance with the dimensions shown in **Table 3** and **Figures 84 and 85** below.

TABLE 3

Fire-Lite+ Recessed Application (MAGNUM 60 & 72)									
Model	A	B	C	D	E	F	G	H	J*
60	60-7/8"	12"	73-1/2"	30"	29-1/2"	84-7/8"	59-1/2"	28"	1-1/2"
72	73-1/4"	12"	86"	30"	29-1/2"	97-1/4"	59-1/2"	28"	1-1/2"

* THE DIMENSION "J" MAY VARY BASED ON SPECIFIC JOBSITE CONDITIONS, BUT SHALL NEVER BE LESS THAN 1-1/2"

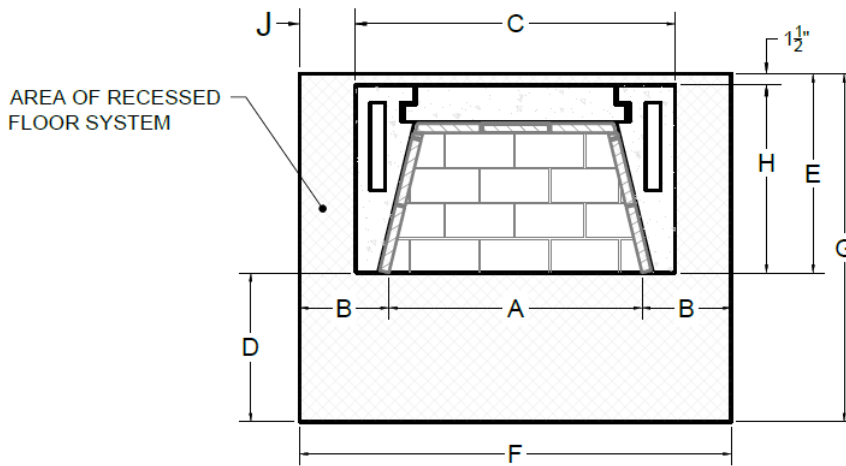

FIGURE 84

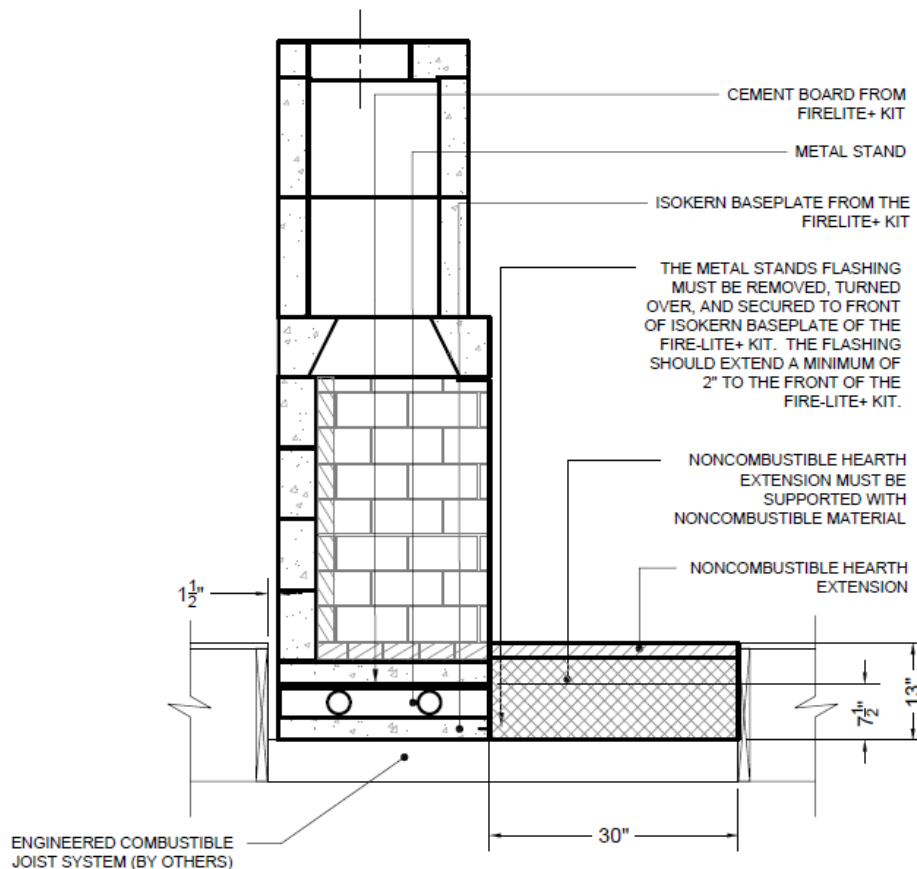
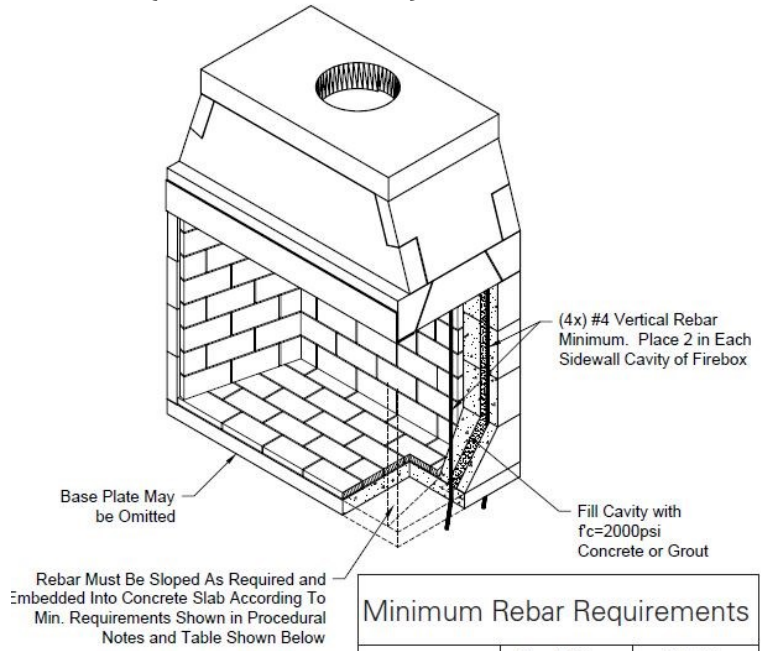

FIGURE 85

Seismic Requirements (Slab on Grade)

PROCEDURE

1. Drill hole of proper diameter and depth using a carbide tipped drill or coring bit. Avoid any existing reinforcing steel by relocating hole slightly.
2. Clean hole thoroughly by vacuum or air pressure.
3. Make sure that the hole is dry and clean before grouting.
4. Place epoxy grout in hole with caulking gun or similar equipment starting at bottom, filling hole approximately 2/3 full.
5. Coat dowel with same epoxy grout and insert into hole, forcing material around the sides of the bar and completely filling all voids.
6. Provide support for dowel by tying to rebar or other element until grout has cured.
7. Epoxy grout in CMU shall be Simpson set epoxy tie (ESR-1772), HILTI HIT-HY 150 max (ESR-1967), or equal.
8. Epoxy grout in concrete shall be HIT-RE 500-SD by Hilti corporation. (ESR-2322), simpson set-xp (ESR-2508) or equal.
9. Special inspection required.



Bar Size	Rod Size (inches)	Bit Dia. (inches)
#3	-	1/2
#4	1/2	5/8
#5	5/8	3/4
#6	3/4	7/8
-	7/8	1
-	1	1-1/8

Summary

Chimney Installation and Draft

Chimney systems will only draft properly when they are installed according to the instructions, in an appropriate location and with the proper chimney height. Installing the fireplace according to the instructions, choosing an appropriate location, and choosing an appropriate chimney height are the responsibility of the designer and the building contractor.

Tightly insulated and sealed homes, two story interior spaces, and high vaulted ceilings can cause negative air pressures within the house which can impair drafting performance. HVAC return air ducts near the fireplace opening will adversely affect the fireplace drafting performance.

It is the responsibility of the designer, the building contractor, and their mechanical contractor to determine that the building's internal air pressures are conducive to positive fireplace drafting.

Avoid placing any fireplace in an area near tall trees, tall buildings, or high land masses. These structures can reduce ambient air flow pressure as well as produce down drafts, either of which can impair fireplace drafting performance.

Earthcore Industries L.L.C. does not warrant drafting and is not responsible for it.

Fireplace Curing Instructions

It is critical that the Isokern masonry elements in the firebox and smoke dome assembly be dry before firing of the unit. Moisture left in the components from exposure during storage and shipping, as well as moisture from the installation phase, must be eliminated before the unit is put to its intended use.

The first step in reducing the ambient moisture is to be sure that the completed fireplace rest in a totally dried-in setting for a minimum of 28 days after construction of the unit is complete.

The next step in curing the fireplace is to set the first five or six fires of short duration. The first fire of the unit can take place once the minimum twenty-eight day drying period has passed. This fire should be especially short.

Start the first fire slowly with a small amount of paper and kindling (small dry wood splits or twigs) and a maximum load of four to six pounds of dry firewood, estimated to be no more than two or three logs each of about three inches (3") to four inches (4") diameter. The first fire should burn for no more than thirty to sixty minutes and then allowed to go out. Do not refuel the fireplace during the first lighting. A cooling-off period of twenty-four hours, at a minimum, should follow the first fire.

The second fire should be the same as the first fire. It should burn for no more than thirty to sixty minutes and allowed to go out. Do not refuel the fireplace during the second lighting. A twenty-four hour cooling-off period must be observed following second lighting.

After first and second fire, continue use of the unit with three or four small fires of short duration (sixty minutes or so) and small fuel load.

After these first five or six small fires of short duration, normal use of the fireplace can proceed. For normal use the maximum recommended fuel load is twelve to sixteen pounds of dry firewood at a time. This fuel load is considered to be approximately three to five cured hardwood logs of about three inches (3") to six inches (6") in diameter. As the fire burns down, refueling should be only one or two logs added at a time.

IMPORTANT: Do not burn construction debris or trash of any kind in the fireplace. Whereas it is not uncommon for construction debris and refuse to be burned in a fireplace by site personnel on a project that is under construction, this activity must be avoided. It is the responsibility of the building contractor to ensure that the required dry-in period is met and that the required lighting sequence is performed by the owner or by the owner's agent.

Log Grates

Log grates are required for burning solid fuel in the Isokern fireplace. Grates allow for easy air flow up through the burning logs thus creating a more complete and efficient burning of the fuel.

Summary

How to Build a Fire

1. Set the fireplace damper in the fully open position.
2. Begin laying the fire by placing several pieces of wadded up paper directly on the log grate.
3. Place kindling (small splits of dry pine or other dry softwood) on top of the paper, enough to loosely cover the paper.
4. Arrange several small, dry hardwood or softwood logs or log splits on top of the kindling layer.
5. Arrange two or three larger hardwood logs (oak, hickory, etc.) or log splits on top of the stack.
6. Ignite the paper at the bottom of the stack. The burning paper will ignite the kindling which will, in turn, set the remaining fuel on fire.

NOTE: Be sure to stack all firewood in such a way that it will settle into the log grate as the paper and kindling layers are burned away. Additional logs can be set onto the fire as each fueling burns down.

NOTE: Ideally, fuel logs should be of a hardwood species that have been air dried for one year or longer. Use of cured or uncured pine logs and uncured hardwood logs for fuel should be avoided. Pine logs and uncured hardwood logs will tend to smolder and burn at relatively low temperatures producing high levels of soot and creosote.

IMPORTANT: Do not throw, toss, jam, kick or otherwise force logs into the Isokern fireplace.

WARNING: Never use gasoline, gasoline type lantern fuel, kerosene, charcoal lighter fluid or other similar liquids to start or “freshen up” the fire in this fireplace or in any fireplace.

WARNING: If processed solid fuel fire-logs are used: Do not poke or stir the logs while they are burning. Use only fire-logs that have been evaluated for the application in fireplace and refer to fire-log warnings and caution markings on packaging prior to use.

Avoid Over-firing this Fireplace

Some examples of over-firing are:

- Burning of scrap lumber, construction debris, pine branches and brush or cardboard boxes;
- Burning small diameter twigs, branches or any other small sized combustible materials in quantities which exceed the volume of the normal log fire;
- Use of artificial wax base logs, trash or other chemicals or chemically treated combustibles.

WARNING: Over-firing can permanently damage this fireplace system.

Disposal of Ashes

It is recommended that the firebox be cleaned of excessive ashes before each use. It is necessary to remove ashes from the open front of the fireplace. To do so, proceed in the following manner:

- Allow the fire to go out and the ashes to cool for at least six to eight hours.
- After the cooling period carefully pick up the ashes from the firebox with a small, metal fireplace shovel or other metal scoop and place them in a metal container with a tight-fitting lid.
- If possible, do not sweep the ashes as this will stir them into the air and disperse them into the room.
- The closed container of ashes should be placed on a non-combustible floor or on the ground, well away from all combustible materials, pending final disposal. If the ashes are disposed of by burial in soil or otherwise locally dispersed, they should be retained in the closed container until all cinders have thoroughly cooled.

Gas Log Sets

If you install a vented gas log set (decorative gas appliance), the log set must comply with the Standard for Decorative Gas Appliance for Installation in Solid Fuel Burning Fireplaces, ANSI Z21.60 or Z21.84 and shall also be installed in accordance with the National Fuel Gas Code, ANSI Z223.1/ NFPA 54 latest edition.

If you wish to install an unvented (vent-free) gas log set, only unvented gas log sets which have been found to comply with the standard for unvented room heaters, ANSI Z21.11.2 are to be installed in this fireplace. Check local codes for compliance for unvented (vent free) gas log sets.

WARNING: Do not operate a vented gas log set in this fireplace with the chimney removed.

Summary

Inspection and Cleaning

At least twice a year in warm climates or monthly during the heating season in colder climates, thoroughly inspect the fireplace and chimney system. Chimneys must be installed so that access is provided for inspection and cleaning. The chimney should be inspected monthly during the heating season.

Inspect the entire flue from the top down for obstructions such as birds' nests, leaves, etc. Such obstructions must be removed.

Check spark arrestor screens for clear flow of smoke every two to four weeks during the heating season.

Inspect the flue periodically during the heating season for the presence of soot and creosote buildup. If creosote or soot has accumulated, it should be removed to reduce the risk of chimney fire.

Have your chimney cleaned and inspected by a professional chimney sweep annually.

WARNING: Do not use chemical fireplace and chimney cleaners that are poured on a hot fire. These can be dangerous and generally work only on the flue section nearest the fire, leaving the rest of the flue unaffected.

Exterior Maintenance

Annually, at a minimum, check all metal flashings and weather seals around the exterior chimney where it penetrates the roof surface; inspect any chimney top spark arrestors, metal cowlings and weather hoods to make sure they are secure and weather tight.

Seal any cracks or gaps in chimney-to-roof flashings to prevent possible roof and chimney chase leaks.

Inspect any cement chimney cap or clay chimney pot terminations to make sure they are not diverting water into the structure. Seal any suspected cracks or gaps in these masonry components.

Notes

Registration Card

Earthcore Industries
Attn: Technical Department
6899 Phillips Industrial Blvd
Jacksonville, FL 32256

Dealer _____

Date of Purchase: _____ Date Of Installation: _____

Address: _____

City, State, Zip: _____

Phone No.: _____

Fireplace Size (Circle One): MAGNUM 60 (82060) 72 (82072)

Fuel Type (Circle One): Solid Wood Natural Gas Propane

Fireplace Serial Number: _____
(Located on Rating Plate Inside Fireplace)

Buyer: _____

Address: _____

City, State, Zip: _____

Phone No.: _____

Installed By: _____

Address: _____

City, State, Zip: _____

Phone No.: _____

Warranty & Disclaimer

Warranty & Disclaimer

Isokern MAGNUM Series Fireplace

Earthcore offers a lifetime warranty for all Isokern components, to be free from defects in materials that negatively affect system performance from the date of purchase, subject to the terms and conditions of this limited warranty.

This warranty covers only the above stated components, and NO WARRANTY, EXPRESS OR IMPLIED, EXTENDS TO ANY OF THE HARDWARE, FOOTING, VENTS, DUCTING, metal flues, FIREBRICK OR ACCESSORIES. THIS WARRANTY DOES NOT COVER DRAFTING, SMOKING OR PUFFING OF THE FIREPLACE SYSTEM. Factors beyond the manufacturer's control affect fireplace drafting, smoking, and puffing, and Earthcore cannot guarantee these aspects of performance.

If a component is found to be defective under the terms of this warranty the party to whom this warranty is extended shall, notify Earthcore, 6899 Philips Industrial Blvd, Jacksonville, Florida 32256, in writing, by registered mail, within thirty (30) days following the discovery of the defect within the lifetime warranty period. The notice shall contain (1) the date of purchase; (2) place of purchase; (3) address of installation; (4) name, address and phone number of the owner; and (5) a brief description of the defect.

Earthcore, or any division thereof, is not responsible for any labor costs or indirect costs incurred for the replacement of defective components.

Earthcore is not responsible for misuse or mishandling of components. Nothing in this warranty makes Earthcore, or any division thereof, liable in any respect for any injury or damage to the building or structure in which the fireplace or chimney system has been installed or to persons or property therein arising out of the use, misuse, or installation of properly manufactured ISOKERN product.

EARTHCORE, OR ANY DIVISION THEREOF, SHALL NOT BE HELD LIABLE FOR ANY INCIDENTAL OR CONSEQUENTIAL DAMAGES OR EXPENSES ARISING OUT OF THE USE OF THE FIREPLACES OR CHIMNEY SYSTEMS. ALL SUCH DAMAGES AND EXPENSES ARE HEREBY EXCLUDED.

This warranty is null and void when the fireplace or chimney systems are not installed pursuant to the installation instructions provided by Earthcore or local building codes have not been followed completely.

This warranty applies only to those fireplace and chimney systems installed in the continental United States, Alaska, and Canada. If any part of this warranty is found to be unenforceable, the remaining parts shall remain in force and effect.

EARTHCORE HEREBY DISCLAIMS ALL GUARANTEES AND WARRANTIES, EXPRESS OR IMPLIED, BEYOND THE WARRANTIES SET FORTH HEREIN.

earthcore®

6899 Phillips Industrial Blvd. • Jacksonville, FL 32256 • 904.363.3417 • f: 904.363.3408 • earthcore.co