



GBC Gas & WBC Wood Burning Draft Fan System Controls:

Quick Start Guide for usage in Most Fireplace Applications

Version 1

4/21/2025

X-VENTISO - Earthcore

X-VENTISO GBC/WBC Draft Fan Control System IOM

Please read and save these instructions for future reference. The proper installation and maintenance of this system will allow years of dependable service. Read carefully before attempting to assemble, install, operate, or maintain the system components described. Protect yourself and others by observing all safety information. Failure to comply with instructions could result in personal injury and/or property damage!

The X-VENTISO GBC(Gas Burning Control) & WBC(Wood Burning Control) controllers are sealed from the factory and should require no adjustment of any user parameters. In the event that an alarm occurs and fails to clear, or the fireplace is not operating properly, contact us at (817)-393-4029.

DO NOT ATTEMPT TO OPEN THE UNIT AND ALTER ANY SETTINGS. THIS WILL VOID THE WARRANTY.

Installation and maintenance are to be performed only by qualified personnel who are familiar with local codes and regulations and who are experienced with this type of equipment. Personnel should have a clear understanding of these instructions and should be aware of general safety precautions.

DANGER! Always disconnect, lock and tag all power sources before installing or servicing. Failure to disconnect a power source can result in fire, shock or serious injury.

CAUTION! Consult and follow all applicable national, state and local codes. They will supersede this document.

WARNING! No installation use or maintenance should be done in an explosive or hazardous environment.

Introduction

The X-VENTISO GBC WBC control box has been designed to enable fan operation on most fireplaces in the market while continuously monitoring and maintaining draft. These controllers accomplish this by user control of the fan speed based on each application's needs.

The X-VENTISO Wall Control features a slide control with LED's that provide visual monitoring of system status and alarms. It is an intelligent easy to install wall mounted device that is a constant speed controller used to safely exhaust flue products from gas or solid fuel fired fireplaces. The Wall Control meets all code requirements for NFPA211.

X-VENTISO Control features include:

- Adjustable Speed Wall Control with Audio and Visual Alarm Status
- Auxiliary relay outputs
- Air Flow Switch – GBC Current Switch - WBC
- Appliance relay output
- Damper end switch limit inputs – Gas Only
- Two analog outputs for flue fan speed references
- Enable input for remote operation
- Includes battery backup if the control loses power

Note: Information contained within this manual may be updated without notice.

Component List

The X-VENTISO GBC WBC system is made up of several components that are factory preset and configured for most fireplaces.

1. Draft Fan Control System Components

a. Flue System

- i. Chimney fan
- ii. Fan Flue Adapter
- iii. Damper – Gas Only
- iv. X-Ventiso Control Box

2. Control Box Components: Tamper Evident Sealed

- a. X-VENTISO wall controller
- b. VMC motor controller
- c. Pressure transducer – GBC, Current Switch - WBC

Specifications

X-VENTISO Controller

Power Supply Input	95 – 264 VAC, 50-60 Hz, 1 Ph
Output Current	6.0 A max.
Main Protection Circuitry	15 A fuses, field replaceable
Secondary Power Supply	24 VDC, 30 W, Class II, LPS
Secondary Protection Circuitry	Overcurrent protected, overvoltage protected, short circuit protected with auto resetting fuse
Operating Temperature	5 - 104 °F (-15 - 40 °C)
Ambient Humidity	5% to 90 % RH non-condensing
Wiring Connections	Molex Style Quick Connects
Enclosure Rating	NEMA 1, 2, 4, 4X, 12, 13 & IP 65, 66
Enclosure Material	Impact-resistant UV Stabilized Polycarbonate
Enclosure Flame Rating	UL94 V-0, UL746C 5VA
Enclosure Dimensions	10.5 x 7.25 x 3.75 in. / 267 x 184 x 95 mm
Approvals	UL508
Wall Control Audio Mute Switch	Front panel push-button dry contact
Wall Control Back Up Battery	2 x CR2032 Lithium-Manganese Dioxide Coin Cells, 3V, 220 mAH, 3.0 x 20.0 x 20.0 mm

Installation of the X-VENTISO GBC WBC System

Before Installing

Read these installation instructions carefully before installing and commissioning the X-VENTISO GBC or WBC panel. Failure to follow these instructions may result in product damage. Before installing the enclosure verify the area conditions around the installation site.

The enclosure is IP65/66 and may be installed indoors only. Do not use in an explosive or hazardous environment. Avoid locations with severe vibrations or heat.

The X-VENTISO GBC WBC panel contains precision electronic components; avoid areas with electrical noise created by high power equipment, devices, and conductors. Do not route high power conductors adjacent or through panel.

Take electrostatic discharge precautions during installation. Protect internal components from dirt, dust, metal chips, and other debris. Failure to protect components from debris may cause an internal electrical short or overheating of components during operation.

Mounting

Mount the X-VENTISO GBC WBC panel by installing the four mounting feet on the back of the enclosure. Secure to a vertical wall or structure able to support the X-VENTISO GBC WBC panel using 4 suitable fasteners for the weight and support material.

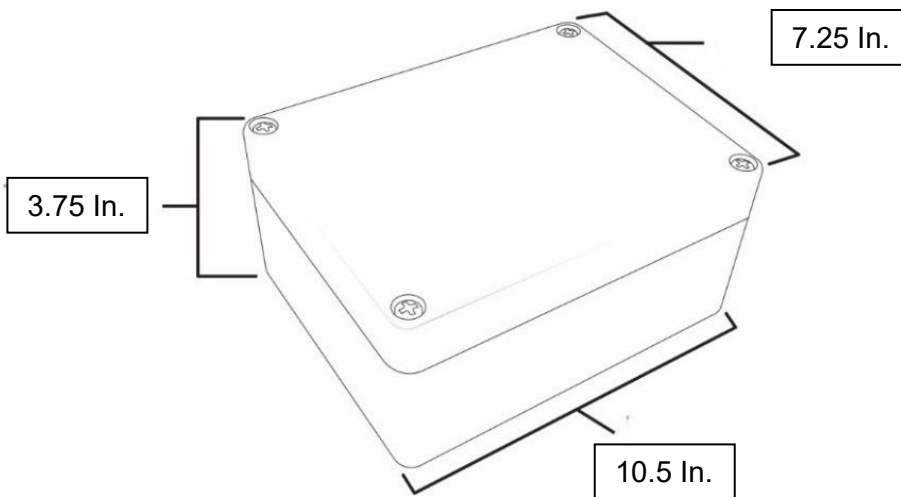

Mounting Brackets



Mounting

The Wall Control installs directly on a standard electrical box. The cover is hooked to the base at the top edge and must be removed from the bottom edge first. Use a small screwdriver to carefully pry each bottom corner if necessary. If a security screw is installed on the bottom edge, then it may have to be loosened or removed also. Tip the cover away from the base and set it aside.

The Wall Control must be removed from the base to access the mounting holes. Follow normal anti-static procedures when handling the control and be careful not to damage any components. The Control is removed by pressing the enclosure base to unsnap the latch near the bottom edge, then the Control can be lifted out of the base. Sit the Control aside until the base is mounted.

After the base is screwed to an electrical box or the wall using the appropriate holes, pull the wires through the wiring hole in the center of the Control and then reinstall it in the enclosure base. Ensure the Control is snapped into the base securely and correctly.

The mounting hole locations are shown on figure 1:

Figure 1

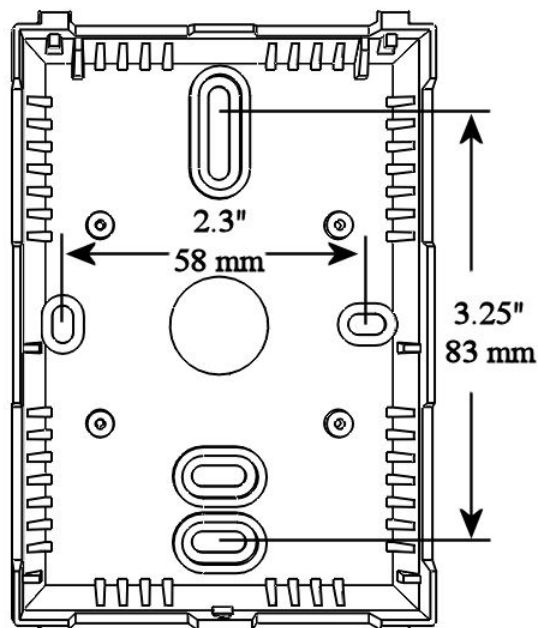

X-VENTISO GBC GAS Burning Draft Fan System: Connection Diagram



X-Ventiso Termination Damper Assembly:
4-pin Molex to Damper Assembly



X-Ventiso Fan and Adapter:
3-pin Molex to Fan



Stack Pressure Probe and Tubing:
Upper (+) Port at side of GBC WBC Control Panel

GBC Controller



Wall Control
6-pin Molex Connection



SIT-2 Ignition Control Module:
4-pin Molex to Gas Control Module with control wiring harness. XV-

For Robertshaw Control Module:
Order Part No. XV-IGN-ADPT-RS

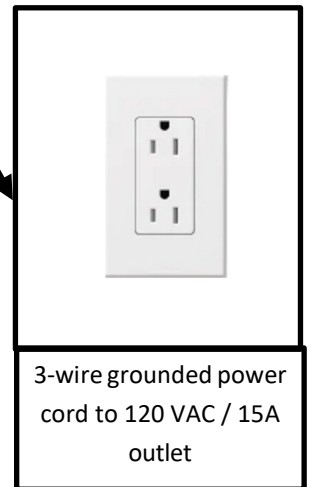

3-wire grounded power cord to 120 VAC / 15A outlet

X-VENTISO WBC Wood Burning Draft Fan System: Connection Diagram

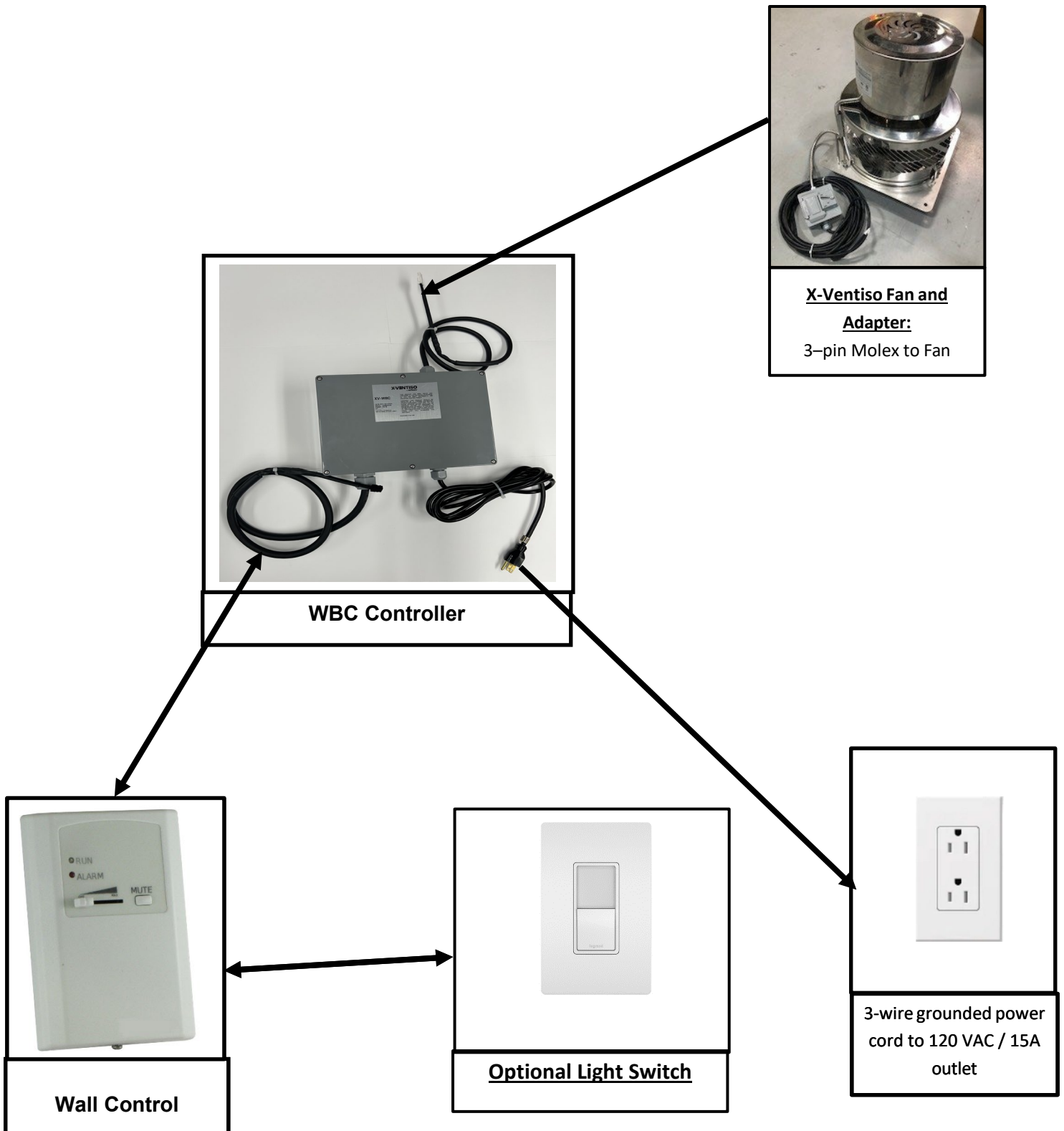

Installation of the X-VENTISO GBC WBC System

1. Install the fireplace and Ignition Control according to manufacturer's instructions.
2. Mount the X-VENTISO GBC WBC Control Panel near the Gas Valve Control box for the fireplace. **NOTE:** The Gas Valve Control Box and the GBC WBC Control Panel shall be installed in a location that is accessible after installation.
NOTE: Ensure the selected location is within the limits specified from the fireplace manufacturer as detailed in the installation manuals.
NOTE: One 120 VAC/ 15 A outlets are required at this location for installation of the GBC WBC Draft Controller and the Gas Valve Control Box. Outlets must be within reach of each unit's 72" power cord.
3. Insert the damper assembly into the last section of flue pipe at the top and ensure the damper is fully inserted. The assembly must be seated flush atop the last pipe section.
4. Run the damper assembly cable to the location of the GBC WBC Control Panel.
5. Install the X-VENTISO Pipe Adapter that is the appropriate size for your flue diameter at the termination
NOTE: For Horizontal terminations the X-Ventiso fan adapter must be anchored into wall framing. Anchorage must be able to support a minimum of 150 lbs. Ensure that all wall penetrations are properly flashed to prevent water intrusion and that the fan adapter is sealed to the structure using non-hardening waterproof sealant.
6. Mount the X-VENTISO Fan to the fan adapter plate with the supplied hardware.
7. Mount the fan disconnect box and run the fan cable to the controller. Conduit should always be installed in a downward orientation for the exterior portion of the cable run.
8. Drill a 3/8" hole into the Flue pipe at a location 12" above the anchor plate. Insert the "Stack" vent probe and mount with the supplied hardware.
9. Connect the "Stack" vent probe tubing to the Stack Pressure Port (Upper/ High Pressure) of the GBC WBC Control Panel.
10. Connect the X-VENTISO GBC 4 pin Molex (White) to the damper cable Extension cable on the back of the wall control – Gas Only
11. Connect the X-VENTISO 3 pin fan Molex (White) to the fan cable.
12. Connect the X-VENTISO 6 pin fan Molex (Black) to the Wall Control.
13. Connect the X-VENTISO 4 pin Molex (White) to the ignition control cable wiring harness for gas applications or to the log lighter in wood burning applications.
14. For Isokern Fireplaces Only - In Gas Valve Control box, connect the Ignition Control Cable wiring harness to terminals X4 & X13 of the Ignition Control Module.
15. Ensure that all gas connections have been made between service, Gas Valve Control Box, and the fireplace/ burner system (main and pilot).
16. For Isokern Fireplaces Only - At the Gas Valve Control Box, ensure that the 3-wire grounded power cord has been connected to the Ignition Control Module (at Terminal X1) and that all wiring harnesses have been connected between the ignition module, and pilot assembly, and gas valve (Terminals X2, X3, X5, & X6) in accordance with the fireplace's installation manual.
17. Plug the Gas Valve Control Box/ Ignition Control Module into one of the 120 V, 15A outlets.
18. Plug in the X-VENTISO GBC WBC Control Box into one of the 120 V, 15A outlets.

Installation of the X-VENTISO GBC WBC System

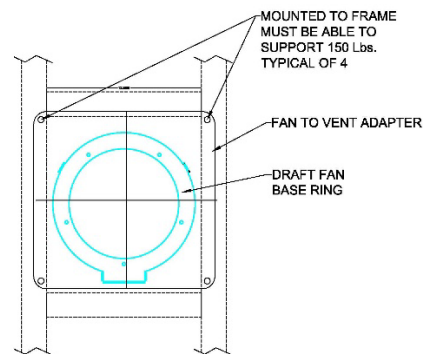
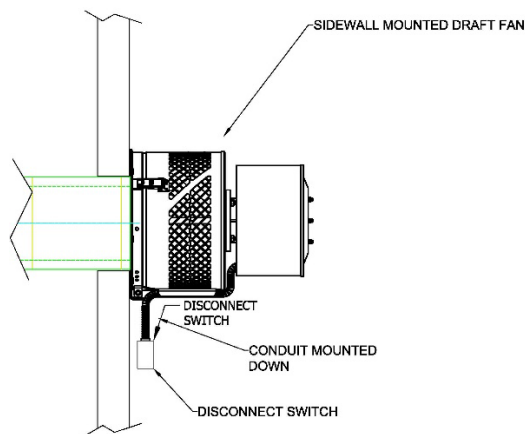
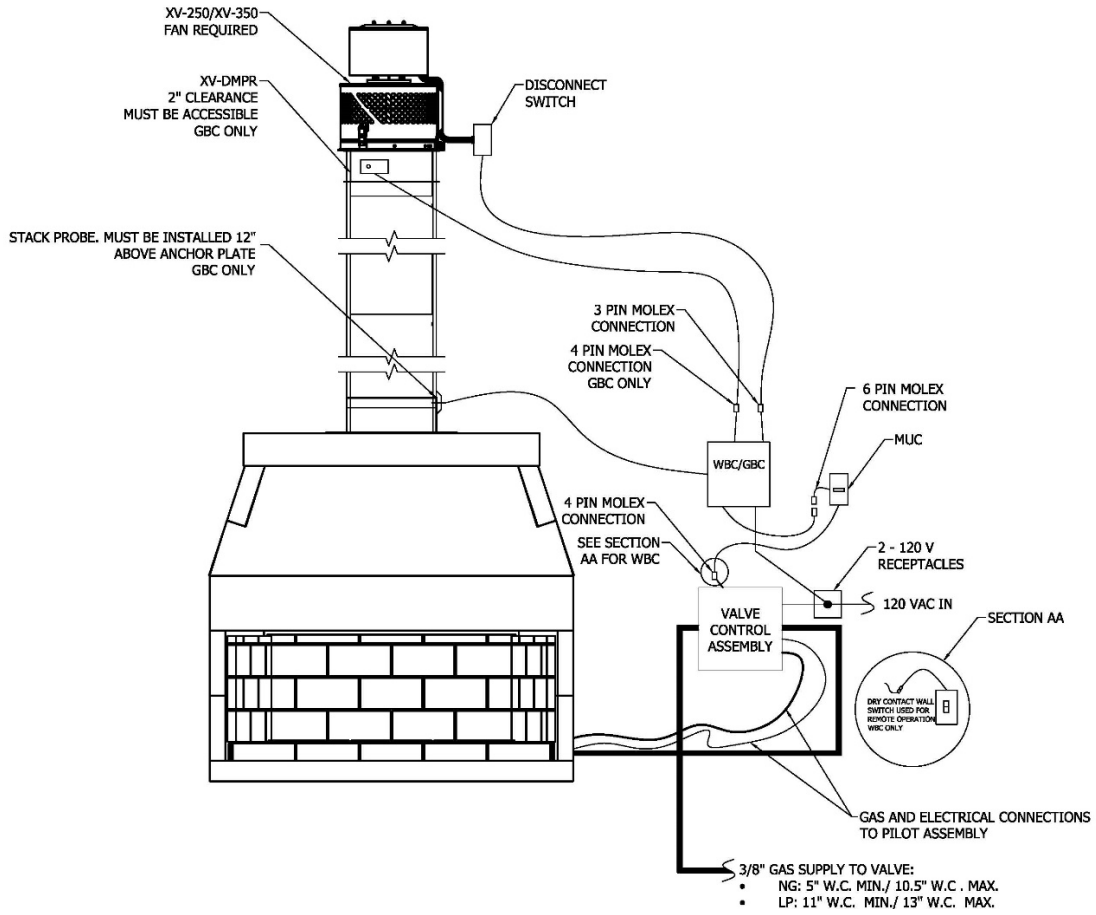

Battery Insertion and Removal

After the WALL CONTROL has been wired completely into the system insert the backup battery tray into its holder on the WALL CONTROL.

When normal operating power is provided to the WALL CONTROL the device will enter normal operating mode and exit back up mode.

To insert the backup batteries into the WALL CONTROL simply slide and push the battery tray into the battery holder on the WALL CONTROL as illustrated in figure 3, ensuring that the positive terminal is facing upwards. To remove the battery tray from the battery holder on the WALL CONTROL simply push on either the bottom or top battery tray tab to pop the tray slightly out from the battery holder on the WALL CONTROL and then pull the tray out from the battery holder as illustrated in figure 3.

Figure 3

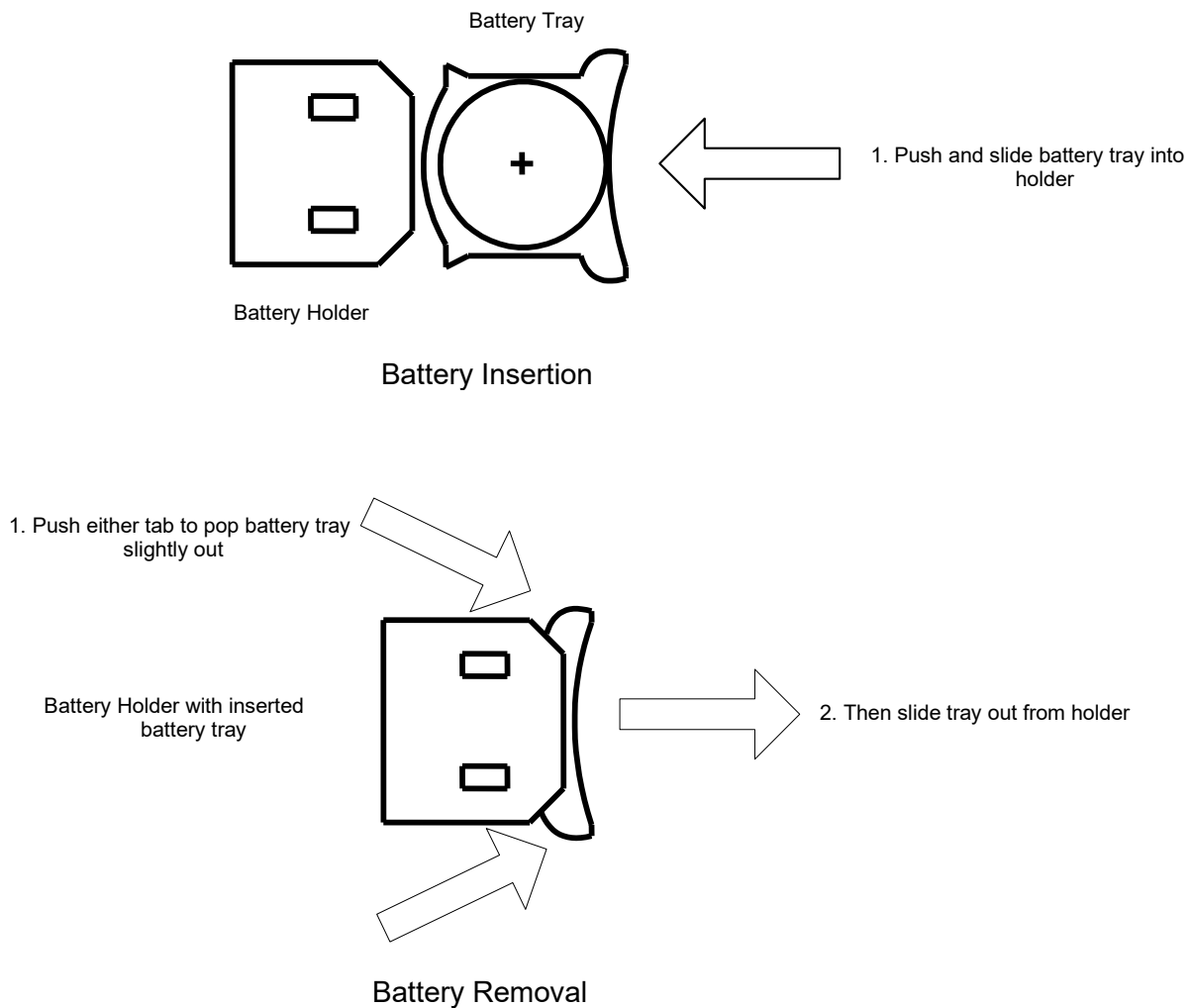

System Operations

The X-VENTISO GBC WBC controller enables the operation of a fireplace system while providing real-time monitoring of the fan, damper, and draft to ensure safe fireplace operation. The controller has been specifically programmed for these applications. Speed adjustment is permitted through the wall controller.

Sequence of Operation

1. **OFF:** system is hibernating waiting for a run command signal
2. **STARTING:** When activated by sliding the arm on the wall controller system verifies damper position and flue fan operation
3. **RUNNING:** system is operating normally
4. **PURGING:** allows the flue fan to temporarily operate after the run command has been secured

Fan Speeds

The user can adjust the flue fan speed by sliding the wall control arm.

Alarm Functions

The X-VENTISO GBC WBC monitors for 3 alarm conditions:

- Flue damper position switch – Gas Only
- Flue air flow switch
- Current to the fan – Wood Only

When the system has a run command, if any one of the 3 conditions exceeds the alarm delay time an alarm activates. If an alarm occurs, the X-VENTISO GBC WBC controller will annunciate the condition via the LED and performs safety actions.

After an alarm event clears the control will automatically resume normal operation.

The X-VENTISO GBC WBC controller is sealed from the factory and should require no adjustment of any user parameters beyond what can be done at the wall control. In the event that an alarm occurs and fails to clear, or the fireplace is not operating properly, contact KWUS at (817)-393-4029.

DO NOT ATTEMPT TO OPEN THE UNIT AND ALTER ANY SETTINGS. THIS WILL VOID THE WARRANTY.

Wall Control Operation - Modes

Run Mode 1 (Slide pot)

When the wall control provides at least 20% movement (from slide pot) and the ENABLE input is energized it will turn on the green LED and energize the damper relay(GBC only) to the closed position.

The gas relay will still remain in the normally open position until the PROVER circuit input is energized by 24VDC, the motor ON voltage feedback is >4 VDC. If these requirements are not met within 15 seconds after the start command the Wall Control will go into Fail mode.

If the controller is in Run Mode and experiences a power loss, then the device enters the Back Up Mode with the alarm being activated.

Off Mode 1 (Slide pot)

When the WALL CONTROL potentiometer is adjusted to the Off position providing a <1.5 VDC signal to the fan motor, the WALL CONTROL enters Off Mode. The WALL CONTROL will deactivate the red LED, green LED and alarm buzzer, and release both the gas relay and damper relay into the normally open position.

Run Mode 2 (Remote Enable Input)

When the WALL CONTROL Enable input terminal is energized and the slide pot is >20% slide it will turn on the green LED and energize the damper relay to the closed position.

The gas relay will still remain in the normally open position until the PROVER circuit input is energized by 24VDC, If these requirements are not met within 15 seconds after the start command the WALL CONTROL will go into Fail Mode.

If the controller is in Run Mode and experiences a power loss, then the device enters the Back Up Mode with the alarm being activated.

Off Mode 2 (Remote Enable Input)

When the Enable input terminal loses the 24VDC input the WALL CONTROL will deactivate the red LED, green LED and alarm buzzer, and releases the gas relay into the normally open position and begins a 60 second (post purge) output off delay timer. After the timer expires the WALL CONTROL will secure the 0-10VDC analog speed signal to motor and releases the damper relay(GBC only) into the normally open position.

Fail Mode (Alarm)

The WALL CONTROL after a 15 second delay will deactivate the green LED, activate the red LED, activate the alarm buzzer and releases the gas relay into the normally open position if any or combination of the following occurs:

1. If the fan motor provides <4VDC
2. The Prover input is de-energized

The damper relay(GBC only) remains in the closed position during Fail Mode.

The WALL CONTROL will automatically reset and resumes normal operation once the alarm condition clears. If the WALL CONTROL should receive the missing feedback signal while in the Fail Mode for at least 2 seconds, then the WALL CONTROL will return to the Run Mode and will deactivate the red LED and alarm buzzer, activate the green LED and drive the gas relay to the closed position.

During Fail Mode, an override (Mute/Silence) switch, when depressed will deactivate the audio buzzer for 2 minutes. After 2 minutes if the WALL CONTROL is still in Fail Mode, the audio buzzer will be activated. Muted audio alert mode will flash the red LED with a 50% duty cycle.

Operations - Inputs and Outputs

LED Display

The wall control has two colored LEDs to indicate RUN and FAIL conditions. These LEDs are also be used to indicate battery status and audio alert mute status. When the green LED flashes during the RUN mode this is a low battery voltage status and indicates the batteries should be replaced.

Green	Red	Indication
OFF	OFF	Not running
ON	OFF	Running normally
FLASHING	OFF	Running - Battery voltage level low
OFF	ON	Fail mode active - alarm condition present
OFF	FLASHING	Fail mode active - Audio muted
ON	ON	Back Up mode active - power loss

Audio Alert

The alarm will be activated during Fail Mode and deactivated during Run Mode. The Audio alert can also be muted by the user for 2 minutes during alarm mode via an override push button switch mounted on the Wall Control.

Testing and Troubleshooting

The X-VENTISO GBC WBC controller has been programmed to monitor for several faults and has several built-in checks that are performed during operation. These faults can be caused by either a hard or a soft condition and are used to notify user (s) when the system is outside of normal operating conditions.

A **hard condition** is a system component that is not functional. A **soft condition** is a result of a system condition caused by the present dynamics of the system or environment. The system dynamics are variables of the system that can change outside of the control of the X-VENTISO GBC WBC controller. Some of these variables are:

1. Changing room pressure
2. Outside weather
3. Controller parameters not adjusted properly for system conditions
4. Varying supply voltage
5. Load larger than flue or duct system capacity
6. Natural draft

In the event that an alarm occurs and fails to clear, or in the unlikely event that the fireplace is not operating properly, contact US at (817)-393-4029.

DO NOT ATTEMPT TO OPEN THE UNIT AND ALTER ANY SETTINGS. THIS WILL VOID THE WARRANTY.

In effort to help analyze any problems that the system may be encountering, the following chart provides a brief description and possible solution to some potential alarms and general operational issues.

Operation - Troubleshooting Chart

Issue Description	Actions
Fan will not run	<ol style="list-style-type: none"> 1. Check supply voltage 2. Check disconnect (s) 3. Verify control potentiometer setting 4. Verify wiring 5. Verify 0-10 VDC signal and polarity at fan motor 6. Check fan motor
Wall Control will not run	<ol style="list-style-type: none"> 1. Check supply voltage between the 24V terminal and the COM terminal 2. Verify the ENABLE input has 24VDC 3. Check Back Up batteries
Red LED On (Fail Mode)	<ol style="list-style-type: none"> 1. Check PROVER circuit 2. Check fan operation
Green LED Flashing	<ol style="list-style-type: none"> 1. Replace batteries

Alarms

Alarm	Description	Possible Causes
DAMPER	<p>Flue damper end switch circuit is open</p> <p>Flue damper failed to prove open for longer than the alarm delay timer setting</p>	<ul style="list-style-type: none"> • Damper actuator wiring • Mechanical blockage of damper • Actuator end switch settings • Actuator and damper timing • Actuator failure
AIR SWITCH GBC Only	<p>Flue air flow switch circuit is open</p> <p>The air switch did not prove draft air flow during operation for longer than the alarm delay timer setting</p>	<ul style="list-style-type: none"> • Flue blockage • Air flow switch wiring • Pressure tubing issue or connection • Air flow switch trip point adjustment • Draft fan disconnect or supply power • Draft fan wiring issue
CURRENT SWITCH WBC Only	<p>Current switch circuit is open.</p> <p>The system current flow is verified by the current switch. If no current is lower than the low limit setting for longer than the alarm delay timer setting</p>	<ul style="list-style-type: none"> • Current Switch Wiring • Draft fan disconnect or supply power • Draft fan wiring issue
HIGH PRESSURE	<p>High pressure limit exceeded</p> <p>The system pressure measured by the pressure transducer is higher than the high limit setting for longer than the alarm delay timer setting</p>	<ul style="list-style-type: none"> • Flue fan speed not aggressive enough • Flue blockage • Motor failure or disconnect open • Damper issue • Pressure tubing on wrong pressure transducer port • Blocked pressure tubing or probe • Pressure transducer failure • Induced voltage into signal wiring • Too large of load for flue system

Fault Reset

If an alarm event exceeds the fault time the X-VENTISO GBC WBC will secure operations and must be manually reset. To reset system after a fault lockout, cycle power to the system.

After resetting a fault lockout perform a system test and troubleshoot cause of alarm.

General Issues

Issue Description	Check / Adjust
Fan does not run	<ul style="list-style-type: none"> • Power supply and disconnect • Wiring connections • Speed reference wiring polarity • Mechanical binding or lockup • Analog output jumpers set to (V)
Damper does not fully stroke	<ul style="list-style-type: none"> • Mechanical obstructions • Damper and actuator timing
Damper does not stroke/rotate	<ul style="list-style-type: none"> • Power supply at actuator • Position signal wire and voltage • Mechanical binding or lockup • Actuator switch settings
Pressure transducer not working - GBC	<ul style="list-style-type: none"> • Supply voltage at transducer terminals • Wiring connections • pressure tube and probe • Input jumper 5 & 6 set to 0-10V
Current sensor not working - WBC	<ul style="list-style-type: none"> • Supply voltage at transducer terminals • Wiring connections • pressure tube and probe • Input jumper 5 & 6 set to 0-10V

System Startup Checklist

Do not skip any steps! Skipping steps may create a hazardous condition or damage equipment!

A. Pre-Startup Checks

- | | | |
|----|---|---------|
| 1. | Verify that disconnect (s) are open/ de-energized and no power is supplied to equipment. | YES/ NO |
| 2. | Verify all system components are installed properly and are secure. | YES/ NO |
| 3. | Verify wiring connections are correct per wiring diagram (s) and terminals are tight. | YES/ NO |
| 4. | Verify all debris has been removed from enclosure/ equipment (metal chips loose, wire strand, etc.) | YES/ NO |
| 5. | Verify fan assembly is clear of obstructions and personnel. | YES/ NO |
| 6. | Verify equipment voltage <u>supplies</u> prior to energizing disconnect (s) . | YES/ NO |

Warning: Do not proceed unless the system is complete and ready to be started. The following procedures will energize the X-VENTISO GBC WBC controller and associated components.

B. General

- | | | |
|-----|---|---------|
| 1. | Verify pre-startup checks have been completed. | YES/ NO |
| 2. | Verify all components installed per installation instructions. | YES/ NO |
| 3. | Verify all MOLEX connections are secure. | YES/ NO |
| 4. | Verify all gas valve connections are properly connected and secure. | YES/ NO |
| 5. | Verify Stack Pressure Probe is properly installed into Flue pipe - GBC | YES/ NO |
| 6. | Verify tubing is connected from the Stack Pressure Probe to the upper port (+) on GBC controller. | YES/ NO |
| 7. | Verify all personnel and equipment is clear rotating equipment! | YES/ NO |
| 8. | Verify Gas Control Valve and GBC WBC Controller are connected to 120 VAC/ 15A outlets. | YES/ NO |
| 9. | Energize Disconnects and verify disconnects are energized. | YES/ NO |
| 10. | Verify remote has been synchronized with Ingintion Control Module per installation manual. | YES/ NO |
| 11. | Energize Fireplace via remote to enable system operation. | YES/ NO |

C. System Tuning

1. Cycle system several times to verify normal operations



**For Technical Support
817-393-4029**